



PEDESTRIAN FACILITIES GUIDEBOOK

**Incorporating Pedestrians Into
Washington's Transportation System**

Sponsored by

**Washington State Department of Transportation
Puget Sound Regional Council
County Road Administration Board
Association of Washington Cities**

Prepared by



September 1997

Table of Contents

Introduction

Why a Pedestrian Facilities Guidebook?	1
Who Will Use This Guidebook?	2
What is the Focus?	2
References and Other Resources	3
Acknowledgments	3

How to Use This Guidebook

How Should the Information in This Guidebook Be Used?	5
Relationship to Other Guidelines and Standards	5
Permission to Reproduce and Copy	6
Where Can You Find the Information You Need in This Guidebook?	6

About Pedestrians

Pedestrians Defined	9
Pedestrian Safety	9
Pedestrian Needs	11
Levels of Use and Travel Characteristics	16

Design Toolkit

Toolkit 1 — General Design Guidelines

Pedestrian Facilities Defined	24
The Importance of Good Design for Pedestrians	24
The “Bigger Picture” — Creating Pedestrian Friendly Communities	26
Creating a Continuous Pedestrian System	28
Creating an Effective Pedestrian System	28
Pedestrian Friendly Streets	30
Other Sources of Information	31

Toolkit 2 — Accessibility

Understanding the ADA	33
Designing for People with Disabilities	34

Table of Contents

Designing for Older Adults	34
Accessible Routes of Travel	35
Eliminating Barriers and Obstacles	35
Widths and Clearances	37
Passing and Resting Areas	37
Grades	38
Cross Slopes	38
Sidewalk Curb Ramps	39
Ramps	39
Handrails	43
Accessibility Across Driveways	43
Surfacing	45
Textural and Visual Cues	45
Site Connections	46
Signing and Other Communication Aids	46
Lighting	46
Other Sources of Information	47

Toolkit 3 – Children and School Zones

Special Considerations Related to Children	50
Improving Student Pedestrian Safety — A Cooperative Process	50
School Related Pedestrian Improvements	51
The School as a Community Focal Point	52
Pedestrian Friendly Schools and School Zones	53
Traffic Control and Crossings Near Schools	57
School Walk Routes and Safety Programs	64
Ongoing Maintenance	64
Other Sources of Information	65

Toolkit 4 – Trails and Pathways

Trails and Pathways Across Multiple Jurisdictions	67
Regional Connectivity	68
Accessibility of Trails and Pathways	68
Multi-Use Trails and Pathways	70
Recommended Dimensions	74
Paving and Surfacing	76
Grades, Cross Slopes, and Drainage	77
Shoulders, Side Slopes, and Railings	77
Connections and Crossings	78
Managing Motor Vehicle Access	78
Vegetation and Landscaping	79
Seasonal and Nighttime Use	80
Maintenance	80
Other Sources of Information	81

Toolkit 5 – Sidewalks and Walkways

Determining When and Where Sidewalks and Walkways are Needed	84
Sidewalks and Walkways in Various Settings	85
Descriptions and Comparisons of Sidewalks and Walkways	86
Location — Both Sides Versus One Side	87
Accessibility	87
Recommended Dimensions	89
Passing, Waiting, and Resting Areas	89
Grades, Cross Slope, and Drainage	90
Side Slopes, Railings, and Walls	90
Surfacing	91
Street Separation and Edge Treatment	92
Street Furnishings, Utilities, and Related Clearances	97
Landscaping and Street Trees	99
Lighting	100
Signing	100
Sidewalks in Business Districts and Downtowns	100
Shoulders as Walkways in Rural Areas	102
Bicycles on Sidewalks	104
Street Design Considerations	105
Maintenance	109
Other Sources of Information	110

Toolkit 6 – Intersections

Effects of Pedestrian Improvements on Vehicle Capacity	114
Common Design Practices for Pedestrian Crossings at Intersections	114
Minimizing the Crossing Distances at Intersections	123
Minimizing Pedestrian/Motor Vehicle Conflicts	129
Other Sources of Information	139

Toolkit 7 – Crossings

Determining the Need for Mid-Block Crossings	142
Mid-Block Crossing Design	143
Railroad Crossings	151
Grade Separated Crossings	152
Multi-Use Trail Intersections and Crossings	156
Boardwalks and Trestles	157
Other Sources of Information	158

Toolkit 8 – Traffic Calming

Why is Traffic Calming Used?	162
Residential Traffic Management	162
Traffic Calming and Management Methods	163
Other Sources of Information	172

Table of Contents

Toolkit 9 – Pedestrian Access to Transit

Transit Compatible Design	176
Improving Transit Facilities for Pedestrians	177
Transit Stops and Bus Pullouts	179
Transit Centers	181
Park-and-Ride Facilities	181
Transit Malls	182
Coordination Between Agencies	183
Other Sources of Information	183

Toolkit 10 – Site Design for Pedestrians

Thinking About Pedestrians as Part of Site Development	186
Pedestrian Friendly Site Design	186
Walkways and Accessible Routes	187
Site Access and Driveway Design	188
On-Site Circulation and Parking	191
Building Location and Design	193
Landscaping and Furnishings	194
Ramps, Stairways, and Steps	194
Sites Used Exclusively by Pedestrians	195
Strategy for Increasing Pedestrian Travel —	
Mixed Use Site Development	198
Other Sources of Information	199

Toolkit 11 – Safety in Work Zones

Protective Barriers	202
Covered Walkways	202
Sidewalk Closure During Construction	202
Intersections and Crossings Near Work Zones	203
Maintenance	204
Other Sources of Information	204

Resource Guide 204

Glossary 215

Index 227

Metric to English Conversion Chart

Comment Request Form

List of Tables

Table 1 — Anticipated Guidebook Users	2
Table 2 — “Design” Focus	2
Table 3 — Pedestrian Facilities Are:	2
Table 4 — Other Documents to Review for Pedestrian Facility Design	6
Table 5 — Common Characteristics of Pedestrian Collisions	10
Table 6 — Some Important Needs of Pedestrians	12
Table 7 — Common Pedestrian Characteristics by Age Group	14
Table 8 — Aids to Older Pedestrians	15
Table 9 — Aids to Pedestrians With Disabilities	15
Table 10 — Why Urban Areas Receive High Pedestrian Use	17
Table 11 — Typical Types of Pedestrian Trips	17
Table 12 — Pedestrian Trip Facts	18
Table 13 — Common Reasons for Low Levels of Pedestrian Travel	19
Table 14 — Ask the Following Questions	20
Table 15 — Expanded Definition of Pedestrian Facilities	24
Table 16 — State Policy for Encouraging Pedestrian Travel	25
Table 17 — Common Characteristics of Pedestrian Friendly Communities	26
Table 18 — Typical Elements of Pedestrian Friendly Streets	30
Table 19 — Definition of Accessible Route of Travel	35
Table 20 — Important Things to Remember About Curb Cuts at Intersections	42
Table 21 — ADA Requirements for Ramps	42
Table 22 — Summary of Accessibility Requirements	47
Table 23 — Most Common Types of Pedestrian/Motor Vehicle Collisions for Children Aged K-6	49
Table 24 — Some Special Limitations of Children Aged 5 to 9	50
Table 25 — Process for Improving Student Pedestrian Safety	51
Table 26 — The School as a Community Focal Point	52
Table 27 — Elements of Good School Site Design	53
Table 28 — Roadside Pedestrian Improvements Along School Walk Routes	55
Table 29 — Potential Traffic Control and Crossing Treatments Near Schools	59
Table 30 — When to Utilize Adult Crossing Guards	62
Table 31 — Primary Functions of Student Safety Patrollers	62
Table 32 — Procedures for Developing School Walk Routes	64
Table 33 — Design Guidelines for Recreational Trails	70
Table 34 — Delineation/Separation Treatments for Multi-Use Pathways	71
Table 35 — Separation Treatments for Multi-Use Pathway Next to Roadway	75
Table 36 — Recommended Dimensions for Trails and Pathways	75

Table of Contents

Table 37 — Priorities for Pedestrians Traveling Along Streets	83
Table 38 — ITE Criteria to Be Analyzed to Determine Pedestrian Safety Deficiencies	85
Table 39 — Recommended Dimensions for Sidewalks and Walkways	88
Table 40 — Advantages and Disadvantages of Planting Buffers	92
Table 41 — Recommendations for Walking Shoulders	104
Table 42 — Access Management	107
Table 43 — Benefits and Disadvantages of One-Way Streets	109
Table 44 — Basic Principles of Intersection Design to Accommodate Pedestrians	114
Table 45 — Guidelines for Installation of Pedestrian Improvements	118
Table 46 — City of Bellevue Recommended Elements to Be Analyzed When Determining the Need for Marked Crosswalks	119
Table 47 — Crosswalk Width and Marking Guidelines	120
Table 48 — Advantages and Disadvantages of Crosswalk Marking Patterns	121
Table 49 — Benefits and Disadvantages of Shortening Curb Radii	125
Table 50 — Locations Where Refuge Islands are Most Beneficial	127
Table 51 — Measures to Improve the Effectiveness of Push Buttons	132
Table 52 — Crossing Distances, Speeds, and Time	133
Table 53 — Reducing Turning Conflicts	135
Table 54 — Design Guidelines for Medians and Refuge Islands	147
Table 55 — Common Residential Traffic Management Program Actions	164
Table 56 — Common Types of Traffic Calming Methods	164
Table 57 — Low Cost Improvements to Increase Pedestrian Access to Transit	179
Table 58 — Pedestrian Friendly Site Design Checklist	186
Table 59 — Checklist for Successful Mixed Use Site Developments	198
Table 60 — Considerations for Pedestrian Safety in Work Zones	202
Table 61 — Work Zone Maintenance	204

List of Figures

Figure 1 — Fatalities Based on Speed of Vehicle	10
Figure 2 — Thinking and Stopping Distances Related to Speed of Travel	11
Figure 3 — Human Dimensions When Walking and Sitting	13
Figure 4 — Spatial Needs for Pedestrians	13
Figure 5 — Spatial Bubbles	14
Figure 6 — Spatial Dimensions for People With Disabilities	16
Figure 7 — Creating an Effective Pedestrian System	29
Figure 8 — Accessible Site Design	36
Figure 9 — Accessible Passing Area	37
Figure 10 — Accessible Ramped Pathway With Landings	38
Figure 11 — Accessible Curb Ramp Design Details	40

Figure 12 — Accessible Sidewalk Curb Ramp Designs	41
Figure 13 — Sidewalk Curb Ramps at Intersections	41
Figure 14 — Handrail Detail	43
Figure 15 — Traditional Driveway Design	44
Figure 16 — Driveway With Wide Sidewalks	44
Figure 17 — Driveway With Planting Strips	44
Figure 18 — Driveway With Sidewalk Behind	44
Figure 19 — Driveway With Dipped Sidewalk	44
Figure 20 — Textural Cues	46
Figure 21 — School Site Design	54
Figure 22 — Sidewalk	55
Figure 23 — Shoulder Walkway	55
Figure 24 — Typical Bus Stop Design for Urban Location	56
Figure 25 — Typical Bus Stop Design for Rural Location	57
Figure 26 — School Signs	63
Figure 27 — One Lane School Marking	64
Figure 28 — Accessible Trail/Pathway	68
Figure 29 — Universal Levels of Accessibility Signs	69
Figure 30 — Multi-Use Pathway Striping	72
Figure 31 — Multi-Use Pathway	72
Figure 32 — Paved Multi-Use Pathway With Separated Soft Surface Trail for Equestrians and Joggers	72
Figure 33 — Pathway Separation From Roadway	73
Figure 34 — Paved Pedestrian-Only Pathway	73
Figure 35 — Unpaved Pedestrian-Only Pathway	73
Figure 36 — Unpaved Multi-Use Pathway	73
Figure 37 — Multi-Use Pathway Pavement Cross Sections	76
Figure 38 — Pathways Requiring Railings	78
Figure 39 — Thickened-Edge Pavement Design	79
Figure 40 — Bollard Spacing	79
Figure 41 — Split Pathway Entrance	80
Figure 42 — Root Barrier	80
Figure 43 — Waiting and Resting Areas	89
Figure 44 — Wall Design Treatments	90
Figure 45 — Planting Buffer Between Sidewalk and Street	93
Figure 46 — Planting Strips Provided as Area for Signs, Utilities, and Street Furnishings	93
Figure 47 — Straight Walkway	93
Figure 48 — Walkway with Slight Meander	93
Figure 49 — Sidewalk Separated by a Ditch	94
Figure 50 — Sidewalk Adjacent to Curb and Gutter	94
Figure 51 — Vertical Curb Adjacent to a Planting Strip	95
Figure 52 — Sidewalk With Rolled Curb	95
Figure 53 — Placement of Extruded or Timber Curbing	96

Table of Contents

Figure 54 — Bike Lane as Buffer Between Pedestrian and Motor Vehicles	97
Figure 55 — Clearance for Sidewalks and Walkways	98
Figure 56 — Pedestrian Travel Way, Clear of Obstructions	98
Figure 57 — Urban Streetside Zone	101
Figure 58 — Shy Distance Between Building and Walkway	101
Figure 59 — Shoulder Walkway	103
Figure 60 — On-Street Parking as a Buffer Between Street and Pedestrian Walkway	105
Figure 61 — Parking Overhang	106
Figure 62 — Access Management	108
Figure 63 — Marked and Unmarked Crosswalks at Intersection	116
Figure 64 — Guidelines for the Installation of Marked Crosswalks at Uncontrolled Intersections and Mid-Block Crossings	118
Figure 65 — Clear Travel Area for Pedestrians at Intersection Corners	119
Figure 66 — Crossing Signs	123
Figure 67 — Reduced Crossing Distance With Reduced Curb Radius	124
Figure 68 — Reduced Curb Radii at One-Way Intersection	124
Figure 69 — Elongated Refuge Island at Right-Turn Slip Lane	126
Figure 70 — Right-Turn Slip Lane and Refuge Island	126
Figure 71 — Median/Refuge Island at an Intersection	128
Figure 72 — Typical Curb Extension Design	128
Figure 73 — Typical Curb Bulb-Out Design	128
Figure 74 — Curb Bulb-Outs and Extensions	129
Figure 75 — Sight Distance at Intersection Corners	129
Figure 76 — Recommended Parking Setback for Sight Distance	130
Figure 77 — Pedestrian Indication Sequence	131
Figure 78 — Modern Roundabout Design	137
Figure 79 — Traffic Calming Circle	138
Figure 80 — Special Paving	139
Figure 81 — Typical Mid-Block Crossing	142
Figure 82 — Mid-Block Crossing of Two-Lane Arterial	144
Figure 83 — Mid-Block Crossing of Five-Lane Arterial With Existing Median	146
Figure 84 — Crossing Signs	149
Figure 85 — Soft Sandwich	150
Figure 86 — Portable Pedestrian Flags	151
Figure 87 — Typical Geometries of Overhead Crossings	155
Figure 88 — Tunnel	156
Figure 89 — Typical Geometries of Underpasses	157
Figure 90 — Traffic Management Approach — Solving the Problems	163
Figure 91 — Recommended Traffic Calming Circle Design	167
Figure 92 — Narrowed Street	168
Figure 93 — Chicanes	168

Figure 94 — Curb Bulb-Outs and Extensions	169
Figure 97 — Raised Crosswalk/Speed Table	172
Figure 98 — Transit Compatible Objectives	176
Figure 99 — Widened Sidewalk in Bus Loading Area	177
Figure 100 — Typical Bus Stop Cross-Section	177
Figure 101 — Bus Shelters and Covered Structures	178
Figure 102 — Same Corner Bus Stop Locations	180
Figure 103 — Pedestrian Friendly Shopping Center	187
Figure 104 — Accessible Building Entrance	188
Figure 105 — Covered Walkways	188
Figure 106 — Driveway Design Comparisons	189
Figure 107 — Wide Planting Areas at Driveway	190
Figure 108 — Access to Transit	191
Figure 109 — Shared Parking Lot	192
Figure 110 — Landing Placement for Stairways	196
Figure 111 — Stair/Step Nosing Design	196
Figure 112 — Pedestrian Plaza	197
Figure 113 — Mixed-Use Site Development Concept	198
Figure 114 — Temporary Pedestrian Routes Around Work Zones	203

Introduction

Why a Pedestrian Facilities Guidebook?

As our state's population continues to grow, we strive to create livable communities that offer a diversity of transportation alternatives including convenient, reliable, safe, efficient, and attractive pedestrian facilities.

Most of us are pedestrians at some point each day, and for some of us, especially children, walking is a primary mode of transportation.



Increasing pedestrian travel and safety are objectives of Washington's Transportation Plan.

Whether we walk several miles a day, use a wheelchair to get from our office to the bus stop, ride a skateboard through the park, or simply walk across the parking lot from our car to the grocery store entrance, all of us have a need for well-designed and properly functioning pedestrian facilities.

To date, there has been limited information published about how to design pedestrian facilities, and no comprehensive design guidelines have been developed for use in Washington. Several existing sources contain design criteria related to pedestrian facilities, although in some design guideline documents, the focus is on enhancing the speed and mobility of motor vehicles, often at the expense of pedestrian needs. In some cases, there is significant design guidance related to bicycle facilities, but minimal advice for design of pedestrian facilities.

As part of the planning process that culminated in the development of the *1994 Transportation Policy Plan for Washington State*, the subcommittee responsible for creating the *Pedestrian Policy Plan* recommended that the Washington State Department of Transportation (WSDOT) coordinate with other state and local jurisdictions to develop a pedestrian design manual that recommends appropriate design practices for pedestrian facilities and provides common sense approaches to improving the pedestrian environment. This guidebook has been created in response to that recommendation.

Anticipated Guidebook Users

Primary Audience

- Traffic and transportation engineers
- Site development and building permit review staff
- Planners and designers, including architects, civil engineers, landscape architects, urban designers, and other design professionals
- Developers

Others Who Might Find the Guidebook Helpful

- School districts
- Neighborhood councils and planning committees
- Metropolitan planning organizations
- Central business district planning organizations/business people
- Small towns
- Officials and politicians
- Special campaigns and programs
- Citizen advocates

Table 1

Who Will Use This Guidebook?

The design guidelines provided in this guidebook will assist WSDOT, cities, counties, private developers, design professionals, and others in designing, constructing, and maintaining pedestrian facilities in a variety of settings, including urban, suburban and rural communities throughout Washington. The primary audience of the guidebook will be transportation design practitioners, including those listed in Table 1.

“Design” Focus

The primary focus of this guidebook is to encourage good planning, design, and engineering practices related to pedestrian facilities. The guidebook also addresses a few important construction, ongoing maintenance, and operational aspects related to pedestrian facilities.

Table 2

Pedestrian Facilities Are:

Sidewalks, trails, curb ramps, traffic calming and control devices, grade separated crossings, wide shoulders and other technology, design features, and strategies intended to encourage pedestrian travel.

Source: Washington State Transportation Policy Plan, 1994

Table 3

What is the Focus?

The focus of this guidebook is on **design** of **pedestrian facilities** (see Tables 2 and 3), but good design is only one component of a successful pedestrian facility. Conscientious planning, effective education programs, and consistent safety and law enforcement also contribute to improving our communities for pedestrians. Some basic principles related to planning for pedestrians are provided in this guidebook, but the overall intent is to encourage good design practices.

References and Other Resources

The technical information contained in this guidebook was compiled from numerous sources. The Resource Guide at the end of the guidebook provides a comprehensive list of sources for information related to pedestrian planning and design, including sources referenced for this document. In addition to the Resource Guide, readers interested in finding additional information related to specific types of pedestrian facilities will find a list of relevant sources of information at the end of each section of the design toolkit. The Resource Guide also lists sources of information related to pedestrian planning, education, and enforcement. The *State Bicycle Transportation and Pedestrian Walkways Plan*, published by WSDOT in 1995, provides comprehensive pedestrian planning information and addresses laws and other plans supporting nonmotorized transportation, costs, and funding opportunities, as well as pedestrian safety education and enforcement.

When no specific source is referenced for graphics, figures, and tables in this document, Otak created those drawings and/or compiled the information especially for use on the Pedestrian Facilities Guidebook. In some cases, other documents or sources of information may have been researched and specifically adapted for this guidebook based on input from the advisory group and other technical experts involved.

Acknowledgments

Funding for this report was provided in part by member jurisdictions of the Puget Sound Regional Council grants from US Department of Transportation, Federal Transit

Administration, Federal Highway Administration, and Washington State Department of Transportation.

Sponsoring Agencies and Organizations

- Washington State Department of Transportation
- County Road Administration Board
- Puget Sound Regional Council
- Association of Washington Cities

Advisory Group Members

- Dave Almond, City of Redmond
- Gary Armstrong, City of Stanwood
- James Bloodgood, Snohomish County
- Bob Bruggeman, Spokane County
- John Dewhirst, Snohomish County
- Chuck Green, Clark County
- Matt Hays, Feet First
- Jon Jainga, City of Federal Way
- Jeanne Krikawa, Seattle Pedestrian Advisory Board
- Tony Mazzella, City of Kirkland
- Kirk McKinley, City of Shoreline
- Michael Meagher, King County
- Phil Miller, King County
- John Milton, WSDOT
- Page Scott, Kittitas County
- David Smith, Kitsap County
- Anne Tonella-Howe, City of Bellevue
- Bob Vogel, Pierce County
- Dave Whitcher, County Road Administration Board
- Sandra Woods, City of Seattle

Other Reviewers

- King Cushman, Puget Sound Regional Council
- Matt Feeney, Puget Sound Regional Council
- Caroline Feiss, Puget Sound Regional Council
- Kathy Johnson, City of Lynnwood
- Kathi Rossi, King County — review of transit related information

Consultant Team

- Otak, Inc.
Mandi Roberts, Project Manager
Tracy Black, Document Editor
in association with:
KJS Associates, Inc.
Pacific Rim Resources, Inc.
Lin & Associates, Inc.

Project Managers

- Mike Dornfeld, WSDOT
- Ned Conroy, Puget Sound Regional Council

How to Use This Guidebook

How Should the Information in This Guidebook Be Used?

The information presented in this guidebook should not be interpreted as standards, specifications, requirements, or regulations, but rather as design guidelines.

The guidelines included in this guidebook apply to normal situations encountered during project development. Unique design problems sometimes require flexibility in design solutions. Other available design information and all applicable federal, state, and local requirements should be reviewed as part of project design.

The information presented in this guidebook may not solve all problems associated with pedestrian travel, but it provides a “first step” in establishing a consistent set of statewide guidelines for design of pedestrian facilities.



Washington pedestrians live, work, and play in a wide variety of settings, and design of pedestrian facilities needs to be adaptable to these settings.

The guidebook can also be used as a tool to build consensus on sometimes differing approaches to design.

The guidelines in this guidebook are often presented in terms of “desirable” and “minimum” dimensions or recommendations. These recommendations should be applied with professional judgement to achieve design solutions that are specifically tailored to the circumstances encountered. For example, if a sidewalk receives a high amount of use, the project designer or local design reviewer may elect to apply the “desirable” dimension over the “minimum” for the sidewalk width.

This guidebook represents the work of the Advisory Group and is not necessarily the position of any of the agencies involved.

Relationship to Other Guidelines and Standards

Cities and counties may already have adopted standards related to design of pedestrian facilities that supersede the guidelines in this guidebook. When no standards have been adopted by federal, state, or local agencies, these guidelines and other documents can provide useful direction to design practitioners. Eventually, local agencies may amend their current design standards to incorporate all or portions of these guidelines.

Pedestrian facilities should be designed and built in accordance with existing federal, state, and local standards as applicable. In

How to Use This Guidebook

some situations, the current standard may not be achievable due to geometric, environmental, or other constraints. In these circumstances, variances from the standard may be acceptable; however, a facility should not typically be built to less than the minimum standards described. Deviations from standards should be documented and

justified through special studies. Refer to the *Local Agency Guidelines (LAG) Manual* for procedures for deviating from standards. Table 4 lists several documents that include other design information related to pedestrians.

Permission to Reproduce and Copy

Permission is granted by the authors and sponsors of this guidebook to all other parties to make and distribute copies of all or portions of the information in this guidebook, without limitations, in accordance with the “fair use” provisions of the United States Copyright Act.

Where Can You Find the Information You Need in This Guidebook?

Look for the Boxes

Important and helpful information is highlighted in boxes like this one, throughout the guidebook.

About Pedestrians

Refer to the next section of this guidebook, About Pedestrians, for information about the needs and characteristics of pedestrians and factors that affect pedestrian travel.

Design Toolkit

The Design Toolkit provides recommendations under 11 topics. A directory of the toolkit topics is provided on the first page of the Design Toolkit for easy reference. Toolkit 1 — General Design Guidelines, provides a general

Other Documents to Review for Pedestrian Facility Design

- Local design standards, zoning codes and development codes
- *Americans with Disabilities Act (ADA) Federal Requirements*
- *Manual on Uniform Traffic Control Devices*, Federal Highway Administration, USDOT
- *A Policy on Geometric Design of Highways and Streets*, American Association of State Highway and Transportation Officials (AASHTO)
- *Uniform Building Code (UBC)*, International Conference of Building Officials, and/or locally adopted building code
- *Local Agency Guidelines Manual*, WSDOT
- *A Guidebook for Student Pedestrian Safety*, WSDOT
- *A Guidebook for Residential Traffic Management*, WSDOT
- *Design Manual*, Section 1020 Facilities for Nonmotorized Transportation, WSDOT
- *Guide for the Development of Bicycle Facilities*, AASHTO

Note: This is only a partial list and does not include all available resources. See the Resource Guide for other relevant publications

Table 4

overview of design considerations related to pedestrians and creating pedestrian friendly communities. Toolkit 2 — Accessibility, provides recommendations and guidelines related to accessible design and compliance with the Americans with Disabilities Act (ADA). The remaining toolkit sections focus on more specific areas of pedestrian facility design.

Resource Guide

Look in the Resource Guide near the end of this guidebook for a comprehensive list of sources related to planning and design of pedestrian facilities. Relevant sources of information related to pedestrian facilities addressed are also listed at the end of each toolkit section.

Glossary

A glossary is provided at the end of this guidebook. Terms and acronyms related to pedestrian facilities addressed in this guidebook are defined and described.

Index

The index at the end of this guidebook provides an alphabetical listing of subject headings and words to help you quickly find information about specific topics.

Metric to English Conversion Chart

Dimensions are shown in metric throughout the document with English equivalents following in parentheses. A metric to English conversion chart is provided near the end of the guidebook for easy reference purposes.

Comment Request Form

A comment request form is provided on the last page of the guidebook. If you have comments on the guidebook, please fill out this form and return it to the WSDOT address shown. Your input will be referenced for future updates and revisions to the guidebook.



Sometimes, there's more than "one-way" to find the best solution for design of pedestrian facilities.

About Pedestrians

Understanding the needs and characteristics of pedestrians and factors that affect pedestrian travel is important when designing pedestrian facilities. This part of the guidebook describes the many types of pedestrians and provides information about pedestrian safety and current research on levels of pedestrian travel.

Pedestrians Defined

Every trip begins and ends as a pedestrian trip — whether walking to a bus stop or across a parking lot to your car.

Washington State law defines a **Pedestrian** as:

“Any person who is afoot or who is using a wheelchair or a means of conveyance propelled by human power other than a bicycle” (RCW 46.04.400),



Every trip begins and ends as a pedestrian trip.

and a **Handicapped Pedestrian** as:

“A pedestrian, or person in a wheelchair, who has limited mobility, stamina, agility, reaction time, impaired vision or hearing, or who may have difficulty walking with or without assistive devices” (WAC 236-60-010).

By state definition, rollerskaters, in-line skaters, and skateboarders are also pedestrians.

Pedestrian Safety

Analysis of pedestrian/motor vehicle collisions can help establish engineering, education, and enforcement solutions. Most reported pedestrian injuries are a result of collisions with motor vehicles. The Washington Traffic Safety Commission reported that there were 2,029 pedestrians struck by motor vehicles in the state of Washington in 1995. Of those, 75 pedestrians were killed, accounting for 11.5 percent of all persons killed in traffic-related collisions.

According to *Walk Tall: A Citizen's Guide to Walkable Communities*, published by the Pedestrian Federation of America in 1995, the average cost to society of a pedestrian-motor vehicle collision is \$312,000, or a total of \$32 billion each year, nationwide. Common characteristics of pedestrian collisions are listed in Table 5.

Vehicle speed is a significant factor in causing fatalities as a result of pedestrian collisions.

Common Characteristics of Pedestrian Collisions

- Driver inattention
- Struck by vehicle while crossing at an intersection (50 percent of all collisions)
- Struck by vehicle while crossing mid-block (33 percent of all collisions)
- Struck from behind while walking along the roadway in the same direction as traffic (particularly in rural areas)
- Motorist exceeding safe speed (contributes to most pedestrian deaths)
- Darting out into the street at mid-block (most common type of pedestrian collision for children)
- Vehicles backing up (difficult to see children and others walking behind)
- Collisions in urban areas (80 percent of all collisions)

Sources: Washington State Bicycle Transportation and Pedestrian Walkways Plan; Pedestrian and Bicycle Crash Types of the Early 1990s; (Snyder, Knoblauch, Moore, and Schmitz; Cross and Fisher)

Table 5

The faster a motorist drives, the more likely injuries to a person on foot will result in death. The chart in Figure 1 illustrates the rate of death that occurs in correlation to the speed of a vehicle involved.

As the figure shows, when collisions occur with the vehicle travelling at a speed of 65

Fatalities Based on Speed of Vehicle

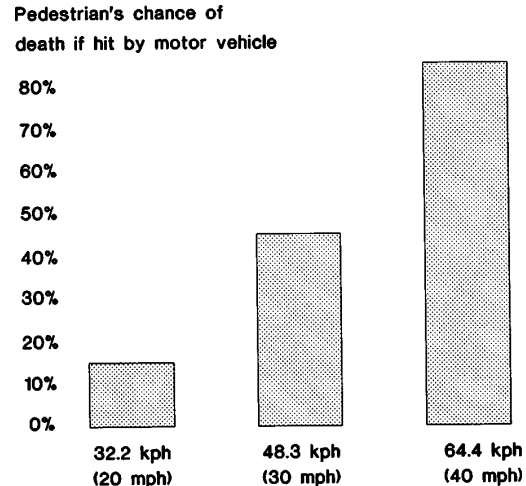

Source: Walk Tall: A Citizen's Guide to Walkable Communities

Figure 1

kph (40 mph), 85 percent of pedestrians are killed, compared to a death rate of 45 percent at a vehicle speed of 50 kph (30 mph), and only 5 percent at a vehicle speed of 30 kph (20 mph). The ability to stop in time for crossing pedestrians also significantly decreases as vehicle speed increases, as shown in Figure 2.

Another common reason for pedestrian/automobile collisions is driver inattention. In 1995, the Washington Traffic Safety Commission conducted a survey to measure driver compliance with the pedestrian crosswalk law. Over one-third of observed drivers did not fully comply with this law.

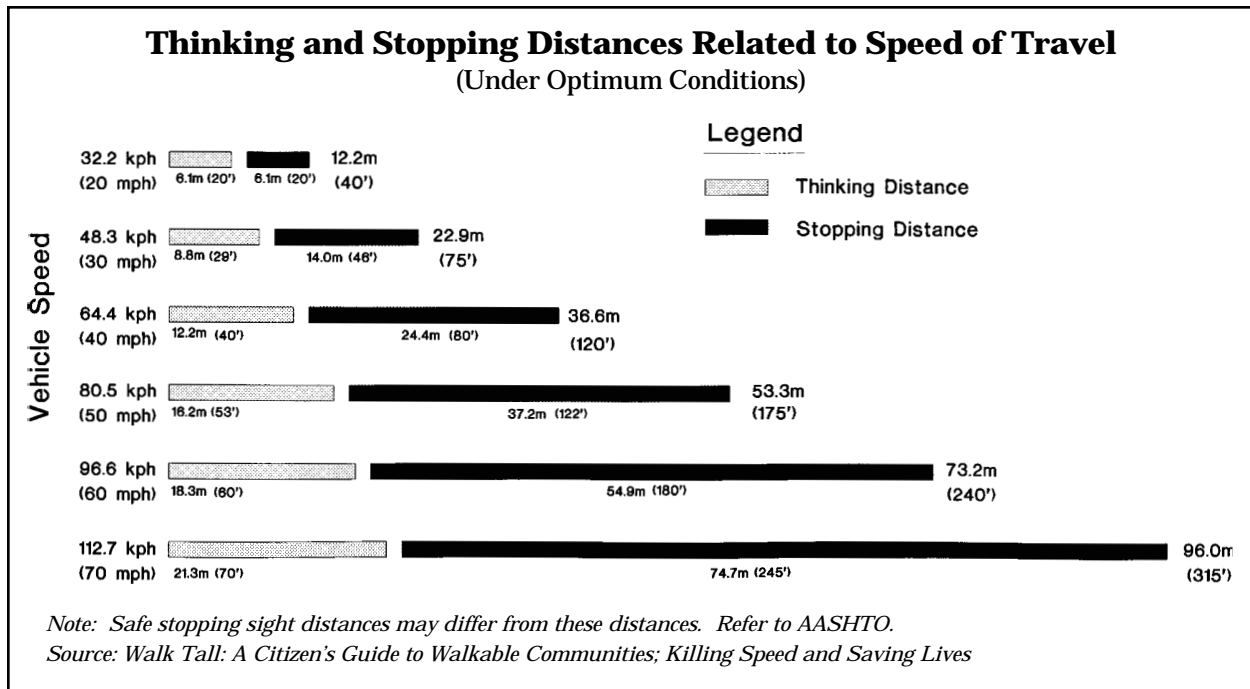

Figure 2

Children and Older Adults

Pedestrians most likely to be involved in collisions are also the ones who most rely on pedestrian travel for transportation — children and older adults. In Washington, children and young adults age 5 to 19 constitute only 21.8 percent of the population; yet between 1990 and 1995, this group accounted for 34.3 percent of all pedestrian injuries nationwide (*Washington State Pedestrian Collision Data, 1990 to 1995*). According to the Washington State Department of Health, in 1989-1990, pedestrian collisions were the third highest cause of hospitalizations for unintentional injuries of children between the ages of 5 and 14 years in Washington. The Washington Traffic Safety Commission reported in 1995 that the age groups of 10 to 14 and 15 to 19 were struck by motor vehicles at a much higher average rate than other age groups.

People over age 65 represented 13 percent of the national population in 1992; yet accounted for 23 percent of all pedestrian deaths during that same year (*Walk Alert, National Pedestrian Safety Program Guide*). Pedestrians over 65 are two to four times more likely to die when involved in a pedestrian-motor vehicle collision. Older adults are particularly more vulnerable while crossing the street, since they need more time to cross.

Pedestrian Needs

In order to successfully design pedestrian facilities, we must recognize that pedestrian needs are wide-ranging, and our design approach must be flexible to meet the diversity of needs.

For some of Washington's population, pedestrian travel is the primary mode of transportation. Citizens in this segment of the population include those who do not use a

About Pedestrians

motor vehicle including some older adults, children and young adults, people who walk to the bus or other forms of transit, people with certain disabilities, and people who can't afford to own cars. There are also many who choose pedestrian travel as their primary mode.

One common obstacle in design of pedestrian facilities is assuming that one standard can be applied to fit an “average” population. For example, the speed that pedestrians travel can vary greatly, yet pedestrian signals are often timed for average walking speeds of 4.8 to 6.4 kph (3 to 4 mph). Children, older adults, and people with certain disabilities typically travel at much lower walking speeds 3.2 kph (2 mph).

Pedestrian needs are diverse. Some typical pedestrian needs are listed in Table 6.

Some Important Needs of Pedestrians
<ul style="list-style-type: none">• Safe streets and walking areas• Convenience• Nearby places to walk• Visibility• Comfort and shelter• Attractive and clean environment• Access to transit• Interesting things to look at while walking• Social interaction

Table 6

Acceptable Walking Distances

Acceptable walking distances will vary depending on geography, climate conditions, and land use patterns. The distance pedestrians will travel is also influenced by the weather, the time of day, demographics, the purpose of their trip, and many other factors. Most people will walk longer distances for recreational purposes, but prefer to walk shorter distances when they are commuting or in a hurry, such as from the bus stop to their office. Guidelines for acceptable walking distances are listed below.

- Traditionally, planners strive to locate community facilities, neighborhood parks, and other popular pedestrian origins and destinations no more than 400 meters (one-quarter mile) from the origin of most pedestrian travel.
- Site designers typically use 90 meters (300 feet) as the maximum distance from parking and site pedestrian circulation to building entrances. Street crossings are typically most effective when located approximately 120 to 180 meters (400 to 600 feet) apart in areas heavily used by pedestrians.
- *A Guide to Land Use and Public Transportation, Volume I*, published by SNO-TRAN, states that pedestrians can be expected to travel about 300 meters (1,000 feet) to a transit stop or park-and-ride space — about 230 meters (750 feet) for mobility impaired — and about 535 meters (1,758 feet or one-third mile) to a commuter rail station.

Spatial Needs

Figure 3 illustrates approximate human dimensions when walking and sitting. For two people walking side-by-side or passing each other while travelling in opposite directions, the average space taken up is 1.4 meters (4 feet 8 inches).

Walking rates slow when pedestrian volumes increase and square footage per person decreases. Figure 4 illustrates how average

flow volumes decrease on walkways with increasing degrees of pedestrian density. A spatial bubble is the preferred distance of unobstructed forward vision while walking under various circumstances. Figure 5 illustrates the spatial bubbles that are comfortable for the average pedestrian while attending a public event, shopping, walking under normal conditions, and walking for pleasure. This information is helpful to the designer for use in calculating how much forward clear space is necessary to maintain a reasonable degree of comfort for pedestrians.

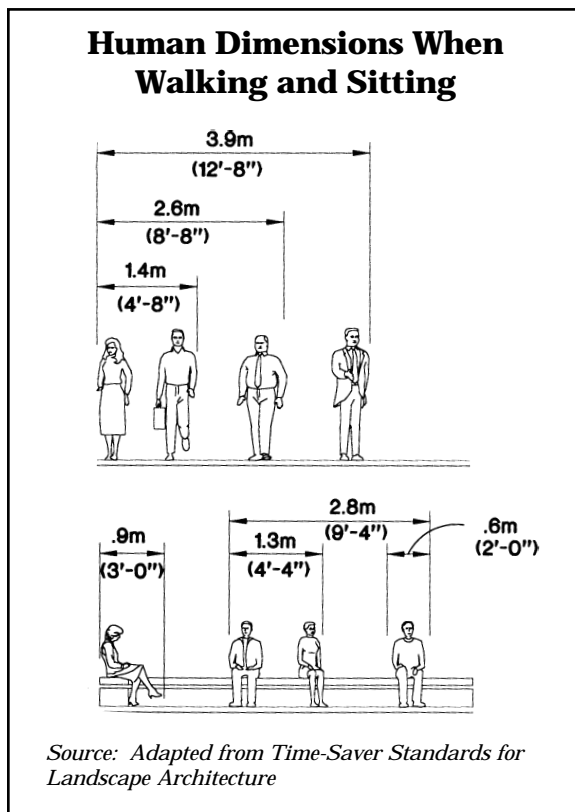

Figure 3

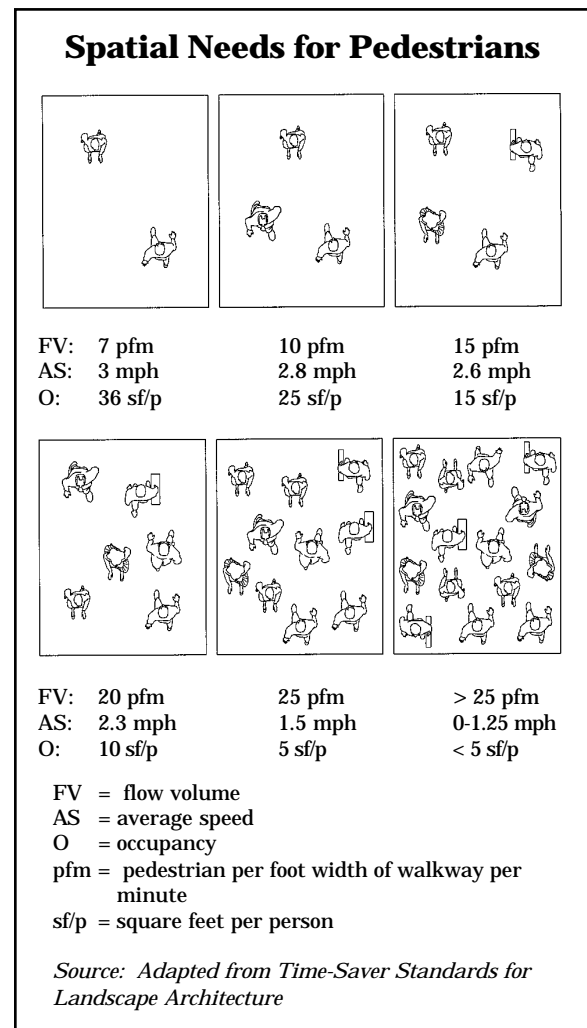

Figure 4

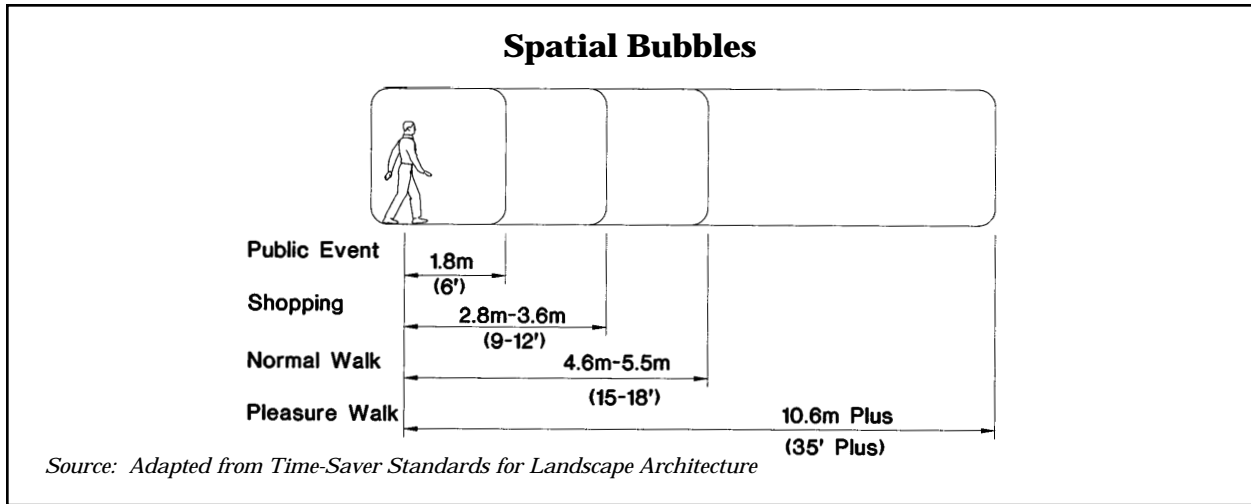

Figure 5

Children and Older Adults

Different pedestrian age groups have different needs. Table 7 summarizes common pedestrian characteristics related to age groups.

The primary need of young pedestrians is adult supervision. Even design with the best of intentions cannot fully protect children from the dangers of streets. Educational programs geared toward increasing a child’s awareness of traffic and safety measures are an important tool to increasing their safety as pedestrians. In addition to adult supervision and effective education programs, good design of the places children walk most, such as school zones and school walking routes, neighborhood streets, and parks, can significantly help to improve their safety.

Older adults have a variety of needs as pedestrians. Research shows that people over 60 walk more, yet in some cases may have impaired mobility. Table 8 lists some examples of elements that aid older adults in their travel as pedestrians.

Common Pedestrian Characteristics by Age Group	
Age 0 to 4	<ul style="list-style-type: none"> • Learning to walk • Requiring constant parental supervision • Developing peripheral vision, depth perception
Age 5 to 12	<ul style="list-style-type: none"> • Increasing independence, but still requiring supervision • Poor depth perception • Susceptible to “dart out”/ intersection dash
Age 13 to 18	<ul style="list-style-type: none"> • Sense of invulnerability • Intersection dash
Age 19 to 40	<ul style="list-style-type: none"> • Active, fully aware of traffic environment
Age 41 to 65	<ul style="list-style-type: none"> • Slowing of reflexes
Age 65+	<ul style="list-style-type: none"> • Street crossing difficulty • Poor vision • Difficulty hearing vehicles approaching from behind • High fatality rate

Source: Washington State Bicycle Transportation and Pedestrian Walkways Plan, 1994

Table 7

Aids to Older Pedestrians

- Reduced roadway crossing distances (bulb-outs and curb extensions)
- Signals within 60 feet of viewing distance; easy-to-read signs
- Refuge areas in roadway crossings
- Traffic calming
- Shelter and shade
- Handrails
- Smooth surfaces and unobstructed travel ways
- Signal timing at lower than average walking speed

Table 8

People With Disabilities

People with disabilities, including those using special walking aids or wheelchairs, need carefully designed facilities that eliminate barriers.

The needs of pedestrians with disabilities can vary widely depending on the type of disability and level of impairment. Elements that are helpful to people with disabilities are listed in Table 9.

Space requirements for pedestrians with disabilities vary considerably depending upon their physical abilities and the assistive devices they use. Spaces designed to accommodate wheelchair users are generally considered to be functional and advantageous for most people. Figure 6 illustrates the spatial dimensions of a wheelchair user, a person on crutches, and a sight-impaired person.

Aids to Pedestrians With Disabilities

- Curb cuts and ramps
- Tactile warnings
- Easy-to-reach activation buttons
- Audible warnings and message systems
- Raised and Braille letters for communication
- Signal timing at lower than average walking speed
- Maximum grade of 1:20 and cross slope of 1:50 (ramps can be 1:12)
- Roadway crossing refuges
- Reduced roadway crossing distances (bulb-outs and curb extensions)
- Traffic calming
- Handrails
- Smooth surfaces and unobstructed travel ways

Table 9



Research shows that older adults walk more than other age groups.

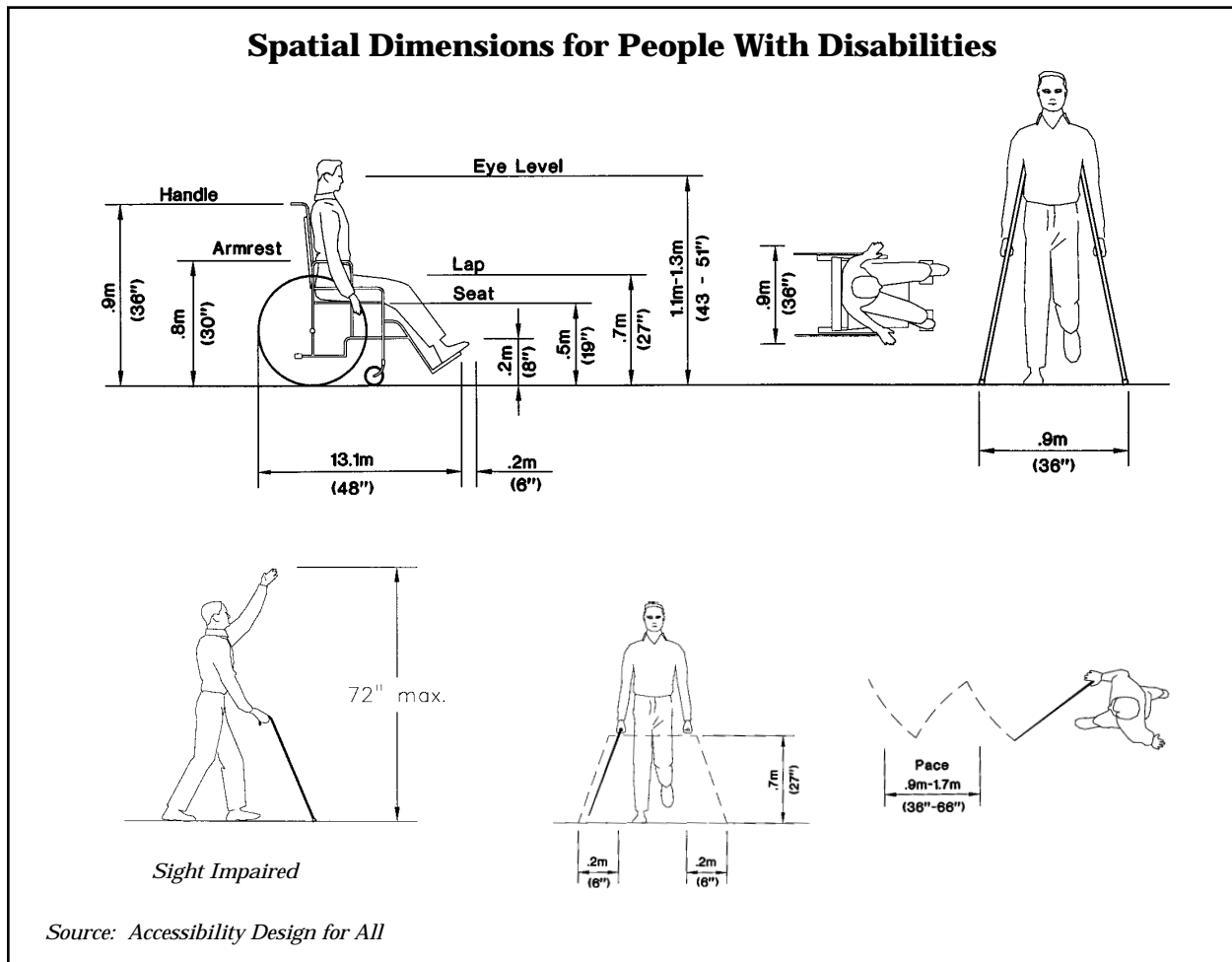

Figure 6

Levels of Use and Travel Characteristics

Various Settings

Different areas in Washington experience different levels of pedestrian travel. In certain urban areas, the level of walking is higher. In Seattle, for example, approximately seven percent of commute trips are walking trips. The Centennial Trail along the Spokane River provides a pedestrian and bicycle link through Spokane and is considered the centerpiece of successful redevelopment efforts in the city center. Table 10 lists some reasons why urban areas receive high pedestrian use.

In spite of the two good examples of Seattle and Spokane, walking typically still only comprises between one and four percent of all commute trips in Washington overall. This low pedestrian commute percentage leads to the conclusion that there is an enormous amount of untapped potential to increase walking as a mode of commuting in Washington (*State Bicycle Transportation and Pedestrian Walkways Plan*).

Pedestrian travel is higher in urban areas, but pedestrians can also be found in suburban and rural areas. There is a common misconception that people who live in the suburbs do not walk, but research indicates that this is not

Why Urban Areas Receive High Pedestrian Use

- Higher densities of residences, businesses, and other origins and destinations
- Traffic congestion
- High concentrations of origin and destination points
- Shopping and services are more accessible to pedestrians
- Average trip distances are shorter
- Parking is too costly or unavailable
- Transit service is more readily available
- More available pedestrian facilities

Table 10

the case, particularly in suburban areas that provide an interconnected and continuous system of well-designed pedestrian facilities. Anne Vernez-Moudon’s research paper, *Effects of Site Design on Pedestrian Travel in Mixed-Use, Medium Density Environments*, December 1996, found that relatively high numbers of people walk in suburban centers, where adequate pedestrian facilities are provided. (See the discussion related to this research later in this section.)

It is also important to recognize that people living in suburban and rural areas travel as pedestrians for different purposes than those living in urban areas. Suburban and rural pedestrian trips are often associated with walking to schools or school bus stops, transit bus stops, or for recreation and leisure purposes, and fewer people walk for the

purpose of running errands, shopping, and travelling to community services.

Trip Characteristics

Pedestrians travel for a wide variety of reasons. In Washington and throughout the United States, pedestrian travel is gaining renewed attention as a form of transportation. Pedestrian travel and other modes of transportation are being encouraged as alternatives to single occupant vehicle travel for energy conservation, reduced traffic congestion, and better air quality. Table 11 lists various types of trips more and more people are choosing to make as pedestrians. Table 12 lists facts related to pedestrian trips.

Research on Pedestrian Use

Research has shown that more people walk in areas where pedestrian improvements and facilities have been constructed.

Typical Types of Pedestrian Trips

(Why People Walk)

- To and from work and school
- Social visits and events
- Appointments
- Health and exercise
- Errands and deliveries
- Recreation
- Extra curricular activities
- Combined (recreational walking while shopping)
- Multimodal trips (walking to a bus stop)

Table 11

Pedestrian Trip Facts

- Pedestrian trips account for 39 percent of all trips less than one mile, ranking second only to private motor vehicle trips
- 73 percent of all pedestrian trips are less than one-half mile
- One out of five trips is work related

Sources: Washington State Bicycle Transportation and Pedestrian Walkways Plan; Best Foot Forward Pedestrian News

Table 12

University of Washington Study

As previously discussed, recent research conducted by the University of Washington Department of Urban Planning (Dr. Anne Vernez-Moudon) studied 12 locations in the Puget Sound region, six in urban areas and six in suburban areas, each with similar population densities, land use characteristics, and demographics. The variable at each location was the extent of pedestrian facilities provided. The study established two primary criteria for measuring the extent of facilities: completeness of the pedestrian network (extent, distribution, and type of facilities); and pedestrian route directness (travel distance, distance contour, and related densities).

According to this research, the measures traditionally used to predict pedestrian volumes (population density, land use distribution, and intensity) are insufficient to explain pedestrian volumes. Site design, community layout (block size), and the presence of pedestrian facilities must also be considered. This research confirms that pedestrian volumes in suburban areas have the potential to increase when facilities

(sidewalks, walkways, crosswalks, and other improvements) are added.

The foregone conclusion of this study was that in locations where there were more complete facilities and direct routes provided for pedestrians, there were more pedestrians walking (*Effects of Site Design on Pedestrian Travel in Mixed-Use Medium Density Environments*).

National Biking and Walking Study

The *National Biking and Walking Study*, conducted in 1993, included 24 case studies that provided in-depth information on specific topics related to bicycling and walking. *Case Study No. 4, Measures to Overcome Impediments to Bicycling and Walking*, cited three primary categories of reasons for not walking:

- Facility deficiencies
- Information or knowledge deficiencies
- Motivational deficiencies

Facility deficiencies include lack of adequate facilities and connectivity. Information or knowledge deficiencies are a result of people not knowing about the level of walking opportunities available to them. Motivational deficiencies have to do with attitudes and behaviors — people not walking because distances between origins and destinations are too long, walking is not convenient, the weather is poor, or they feel uncomfortable or unprotected as pedestrians. In many cases information/knowledge and motivational deficiencies would decrease as a result of improvements to pedestrian facilities and expanding the pedestrian network.

Desire for Improved Pedestrian Facilities

Public opinion surveys have shown that people have a desire to walk and would increase the amount of pedestrian travel they do if better facilities were available. One survey conducted at the national level is the *1990 Harris Poll*. In this survey, 59 percent of respondents said they would be willing to walk outdoors or walk more often if there were safe designated paths or walkways (*Pathways for People*, Emmaus PA, 1992). A survey conducted by the City of Bellevue found similar results when polling students in sixth through twelfth grades in Bellevue public and private schools. The *Youth Link Transportation Survey* compiled the responses of 900 students and determined the following findings:

- Approximately 75 percent of the students would consider walking or bicycling to school as an alternative transportation mode.
- There are several factors that would cause students to be more likely to walk to school, including safer crossings (25 percent), better lighting (29.7 percent), better sidewalks (36.5 percent), and people to walk with (44.9 percent).



Pedestrians come in all sizes.

Table 13 lists some common reasons for low levels of pedestrian travel.

Common Reasons for Low Levels of Pedestrian Travel

- Poor facilities; lack of sidewalks or walkways
- Failure to provide a contiguous system of pedestrian facilities
- Concerns for personal safety
- Failure to provide facilities to and from popular origins and destinations
- Inclement weather
- Poor lighting
- Lack of separated facilities

Sources: Washington State Bicycle Transportation and Pedestrian Walkways Plan; National Biking and Walking Study Case Study #4

Table 13

Forecasting Pedestrian Use

At times, pedestrian facility improvements and expansions are not supported because existing use levels are low. As discussed above, there are several studies that have shown that when facilities are added and improved within a community, more people will walk. Design practitioners frequently inquire about more formal methods available to forecast pedestrian use levels.

Forecasting methods may provide a quantitative approach to determining the demand for pedestrian facilities, but this approach shouldn't replace a common sense

About Pedestrians

thought process to determine the necessity for facilities. Table 14 lists questions that should be asked when considering what types of pedestrian facilities should be developed under various circumstances.

Ask the Following Questions

- Are there origins and destinations within acceptable pedestrian travel distances that will generate trips?
 - schools and parks
 - shopping areas
 - medical facilities
 - social services
 - housing
 - community and recreational centers
 - transit/park-and-ride
- Does the existing street or roadway provide pedestrian facilities?
- What is the setting (urban center, residential, rural)?
- Are there high traffic volumes and speeds that could affect pedestrian use?
- Can pedestrians cross without travelling more than 120 to 180 meters (400 to 600 feet) to an intersection or another crossing point?
- Are transit or school bus stops located along the roadway with safe access and crossing?
- Is there an opportunity to complete a contiguous system by filling in existing gaps?
- Are there barriers to pedestrian travel that can be removed or opened (dead-end routes, blocked passages)?

Table 14

Design Toolkit

The design toolkit provides specific design guidelines and information organized under 11 “toolkit” sections:

Toolkit 1	General Design Guidelines
Toolkit 2	Accessibility
Toolkit 3	Children and School Zones
Toolkit 4	Trails and Pathways
Toolkit 5	Sidewalks and Walkways
Toolkit 6	Intersections
Toolkit 7	Crossings
Toolkit 8	Traffic Calming
Toolkit 9	Pedestrian Access to Transit
Toolkit 10	Site Design for Pedestrians
Toolkit 11	Safety in Work Zones

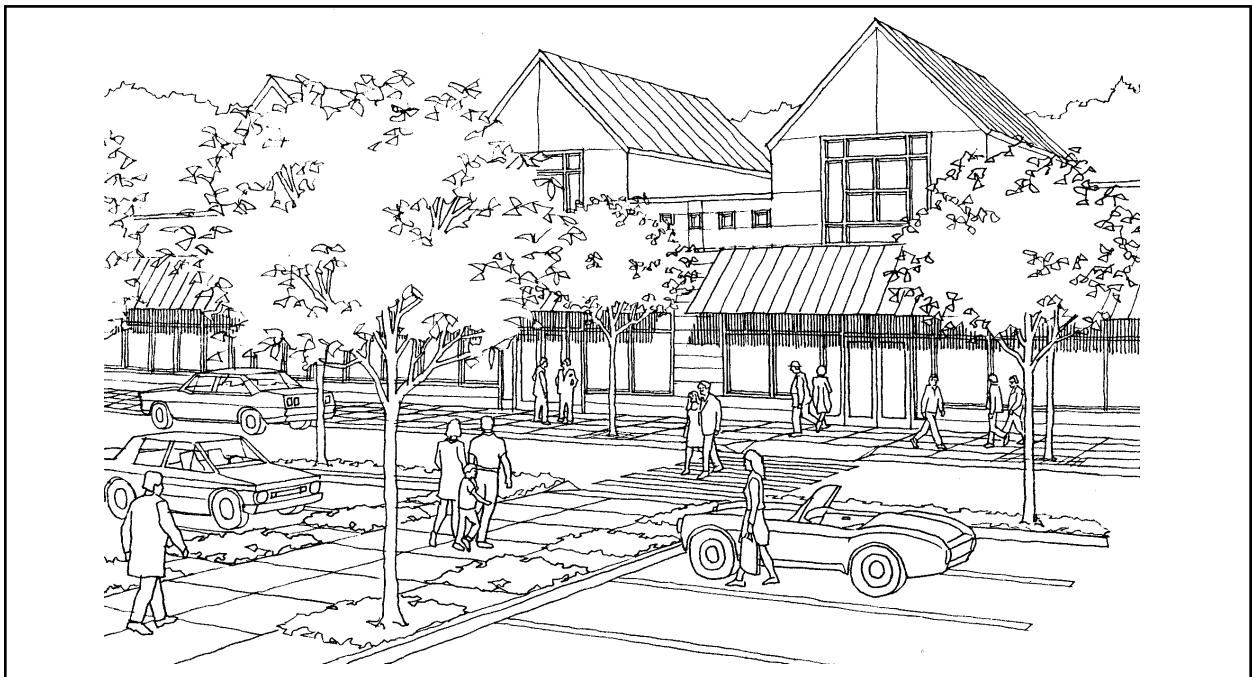

Well designed pedestrian facilities enhance the livability of our communities.

General Design Guidelines

This Toolkit Section Addresses:

- *Pedestrian Facilities Defined*
- *The Importance of Good Design for Pedestrians*
- *The “Bigger Picture” — Creating Pedestrian Friendly Communities*
- *Creating a Continuous Pedestrian System*
- *Creating an Effective Pedestrian System*
- *Pedestrian Friendly Streets*
- *Other Sources of Information*

This section provides an introduction to the design toolkit by first defining “pedestrian facilities” according to Washington law and policy. Next, a brief overview of the importance of good design for pedestrians is provided, followed by a discussion related to some general pedestrian planning and design guidelines that can be applied on a community or region wide basis. The design information presented in this section provides important basic guidance for improving overall conditions for pedestrians in Washington, thereby encouraging pedestrian travel as an alternative to single occupant vehicles and enhancing our quality of life.



Pedestrian “facilities” include more than just sidewalks, as described in Table 15.

Pedestrian Facilities Defined

The 1994 *Washington State Policy Plan* recognizes that “pedestrian facilities” are far more extensive than the simple definition of a sidewalk as defined by Washington law. Table 15 compares the expanded definition of pedestrian facilities to the definition of a sidewalk.

Expanded Definition of Pedestrian Facilities

Pedestrian facilities include:

- Sidewalks and on-street facilities
- Walkways and trails
- Curb ramps
- Traffic calming and control devices
- Crosswalks
- Grade separations (such as underpasses and overpasses)
- Wide shoulders in rural areas
- Furnishings that create a pedestrian friendly atmosphere (such as benches and landscaping)
- Other technology, design features, and strategies intended to encourage pedestrian travel (such as traffic calming devices including traffic circles, speed humps), planting strips, shelters, public art, and lighting

Source: Washington State Policy Plan, 1994

Definition of sidewalk:

A sidewalk means property between the curb lines in the lateral line of a roadway and adjacent property, set aside and intended for the use of pedestrians or such portion of private property parallel and in proximity to public highway and dedicated to use by pedestrians.

Source: Revised Code of Washington (RCW) 46.04.540

Table 15



Pedestrian facilities include furnishings that create a pedestrian friendly atmosphere.

The Importance of Good Design for Pedestrians

Pedestrians are an integral part of Washington’s transportation system. The importance of good design not only applies to development of new facilities, but also to improvement and retrofit of existing facilities for pedestrian use. When pedestrian access is expanded and existing conditions for pedestrians are improved, higher numbers of pedestrians can be expected to use the system. Research has shown that well designed and maintained pedestrian facilities encourage walking and promote higher levels of pedestrian travel.

Pedestrians want facilities that are safe, attractive, convenient, and easy to use. If designed properly, the best public pedestrian facilities can also be the most durable and the easiest to maintain. Poor design of pedestrian facilities can lead to perpetual problems and can actually discourage use if pedestrians are made to feel unsafe, unprotected, or uncomfortable. Unattractive, inadequate, and poorly designed and maintained facilities can be an unfortunate waste of money and resources and a hindrance to community vitality.

Consider pedestrian facilities at the inception of all public and private projects, and address pedestrian needs as part of the total design solution. Examples of considering pedestrian facilities at the onset would be creating a pedestrian circulation master plan as part of preparing a community plan or project specific design such as an intermodal transportation facility. This allows for potential conflicts between transportation modes related to safety and level of service to be resolved early on and avoids the problems of pedestrians being an afterthought in the design process.

Consider the character and setting of the area, nearby land use densities, origins and destinations, and the level of pedestrian use, including the increase in use that may occur when pedestrian improvements are installed. Often, decisions not to install pedestrian facilities are short sighted, based on the perception that an area with low pedestrian use doesn't need improvement. In reality, pedestrians are probably not using the system because it is not adequately meeting their needs under existing conditions. Sometimes land use changes and facilities need to be upgraded to serve more intensive pedestrian travel. After conditions are improved, pedestrian use can almost always be expected to increase, based on recent research findings (see About Pedestrians).

Good design is an important factor in incorporating pedestrians into Washington's transportation system, but it can't be expected to solve all pedestrian related problems. Education and enforcement are other important tools that heighten awareness of pedestrians. Pro-active statewide, regional, and local policy development typically sets the stage for establishing a stronger focus on pedestrian issues and encouraging communities to better

meet pedestrian needs. Table 16 describes the state policy for achieving a multimodal

State Policy for Encouraging Pedestrian Travel

- Local, regional, and state jurisdictions addressing pedestrian issues through comprehensive planning as required by the Intermodal Surface Transportation Efficiency Act (ISTEA)
- Considering pedestrian needs in all transportation facilities
- Reinforcing a sense of neighborhood and community with transportation designs that accommodate pedestrian use
- Ensuring a connected system of pedestrian routes in urban areas
- Enhancing pedestrian mobility and safety in rural areas
- Defining jurisdictional roles in providing pedestrian facilities
- Encouraging land use and transportation development that accommodates pedestrians
- Providing pedestrian facilities that complement local business activity and provide access for employees
- Enhancing intermodal access for persons with impaired mobility
- Maintaining the existing transportation system adequately so pedestrian use is maximized

Source: Washington State Transportation Policy

Table 16

transportation system that encourages pedestrian travel.

friendly communities, as listed at the end of this toolkit section. Some common characteristics of pedestrian friendly communities are listed in Table 17.

The “Bigger Picture” – Creating Pedestrian Friendly Communities

There are many good sources of information about how to plan and design pedestrian-

Common Characteristics of Pedestrian Friendly Communities	
Coordination Between Jurisdictions	Putting pedestrian facilities in place to meet current and future needs requires close coordination between jurisdictions and other modes of transportation.
Linkages to a Variety of Land Uses/ Regional Connectivity	Pedestrian circulation and access is provided to shopping malls, transit, downtown, schools, parks, offices, mixed-use developments, and other community origins and destinations, as well as other communities within the region, as illustrated in Figure 7.
Continuous Systems/ Connectivity	A complete system of interconnected streets, pedestrian walkways, and other pedestrian facilities will increase pedestrian travel.
Shortened-Trips and Convenient Access	Connections are provided between popular origins and destinations, between dead-end streets or cul-de-sacs, or as shortcuts through open spaces, as illustrated in Figure 8.
Continuous Separation from Traffic	Minimized or eliminated street and driveway crossings are provided and well defined. Buffers from motor vehicles and separation of uses are provided.
Pedestrian Supportive Land Use Patterns	Land use patterns, such as a grid layout or short blocks in business districts and downtowns enhance pedestrian mobility.
Well-Functioning Facilities	Adequate width and sight distance, accessible grades, and alignment to avoid blind corners are provided. Common problems, such as poor drainage, are avoided.
Designated Space	Pedestrian facilities should be well delineated, signed, and marked.
Security and Visibility	Design to ensure a secure environment for pedestrians is important. Lighting, increased visibility, open sight-lines, and access to police and emergency vehicles, and locating pedestrian facilities adjacent to

Table 17

Common Characteristics of Pedestrian Friendly Communities (Continued)

Automobile is not the Only Consideration	Streets are designed for all modes of transportation. Parking supply is reduced or managed using methods that encourage walking.
Neighborhood Traffic Calming	Narrowed streets lined with trees, traffic circles, curb bulbs, neck-downs, and other techniques can lower vehicle speeds and create safer conditions for pedestrians.
Accessible and Appropriately Located Transit	Siting of transit facilities adjacent to work, residential areas, shopping, and recreational facilities encourages pedestrian trips. Transit stops and centers should typically be located in areas of supporting densities (4 to 7 units per acre minimum). Development of adequate pedestrian facilities to access transit is essential to their success as an alternative mode of travel.
Lively Public Spaces	Secure, attractive, and active spaces provide focal points in the community where people can gather and interact. Pedestrian pocket parks and plazas are examples.
Character	Preservation of important cultural, historic, and architectural resources strengthens community heritage and character.
Scenic Opportunities	Attractive environments and scenic views encourage pedestrian use, particularly when facilities are oriented toward them.
Pedestrian Furnishings	Providing furnishings, such as benches, restrooms, drinking fountains, artwork and other elements, creates a more attractive and functional environment for pedestrians.
Street Trees and Landscaping	Street trees bring human scale to the street environment. Landscaping and flowers in planting strips, containers, and other areas soften surrounding hard edges of buildings and parking lots and add life, color, and texture to the pedestrian's field of vision.
Design Requirements	Guidelines and adopted standards are followed and, if deviated from, justified and documented.
Proper Maintenance	Frequent cleanup and repair on a regular basis ensures ongoing, consistent use.

Table 17 (Continued)

Creating a Continuous Pedestrian System

The pedestrian transportation system in Washington should be consistent across jurisdictional boundaries and public and private developments. Regional and local pedestrian systems need to be planned, designed, and constructed to provide a comprehensive network of travel options for pedestrians.

The design guidelines in this guidebook encourage more consistent design of pedestrian facilities throughout the state, but the responsibility to develop and support a seamless pedestrian transportation network lies with everyone. Under current state law, local jurisdictions have the authority to require property owners and developers to provide sidewalks (*Washington State Policy Plan*). Targeting public funding so that strategically located projects can be designed and built to fill in the gaps between private development is one way to help improve the overall system. Retrofit of existing areas where pedestrian facilities are inadequate is another important step. The development of a seamless pedestrian system will be the result of both public and private investment throughout neighborhoods and communities.

Coordination between agencies, governments, and private entities is critical to the success of regional pedestrian systems. School districts, utility companies, private corporations, and local agencies need to work together at the onset of transportation and development projects to reach the best solutions for all interests involved. Consider the needs of pedestrians throughout project planning, design, and development processes at all levels, with particular interest toward increasing pedestrian safety and mobility, and improving the pedestrian network overall.

Creating an Effective Pedestrian System

Pedestrian systems and facilities need to be functional and effectively used by pedestrians. The *National Bicycle and Walking Study* conducted by the US Department of Transportation in 1992 provides a broad approach in its description of making a pedestrian system effective. The study states:

“Pedestrian facilities both encourage people to walk and improve pedestrian safety along certain routes. The facilities must be well-designed and maintained to be effective, and must include the following features:

- *Widened paved shoulders to allow safer travel for pedestrians;*
- *Sidewalks, paths or walkways which are wide, relatively clear of obstructions and separated from traffic lanes;*
- *Grade separated pedestrian crossings, which are clearly justified, since such facilities go unused or create illegal street crossing behavior by pedestrians if not properly planned, designed and located;*
- *Pedestrian malls which are well-planned with respect to commercial development, traffic circulation and visual appeal;*
- *Proper design and operation of traffic and pedestrian signals, including pedestrian push buttons, where appropriate;*
- *Barriers that physically separate pedestrians from motor vehicle traffic at selected locations; (see page 30)*

Creating an Effective Pedestrian System

- 1 Locate parking near the buildings they serve.
- 2 Drop-off zones are most convenient when located as close to the primary entrance to the building as possible. Provide curb cuts for pedestrian accessibility. Walkways should be unobstructed. Access to drop-off areas, parking, and building entries should be direct and convenient.

along clear and direct routes throughout the site. Surfaces should be firm and level. Curb cuts and ramps should be provided where necessary. Accessible walkways should be continuous (not dead ends).

- 3 Provide site entrances that are well defined and conveniently located in relation to the site and the building.
- 4 Use clear and easy to read signage to direct pedestrians to their origins and destinations.
- 5 Provide building entries that are clearly identified and accessible. Locate public facilities (restrooms, phones, drinking fountains) near entryways and accessible routes.
- 6 Locate waiting areas within 90 m (300 ft) of building entries. Avoid traffic congestion. Overhead shelters or awnings next to buildings provide protection from weather. Provide adequate seating and lighting.

- 9 Locate transit stops in highly visible and convenient areas. Provide pedestrian shelters.

- 7 Provide resting areas where pedestrians must walk long distances. Benches and other furnishings should not encroach on walkways.

- 8 Provide walkways

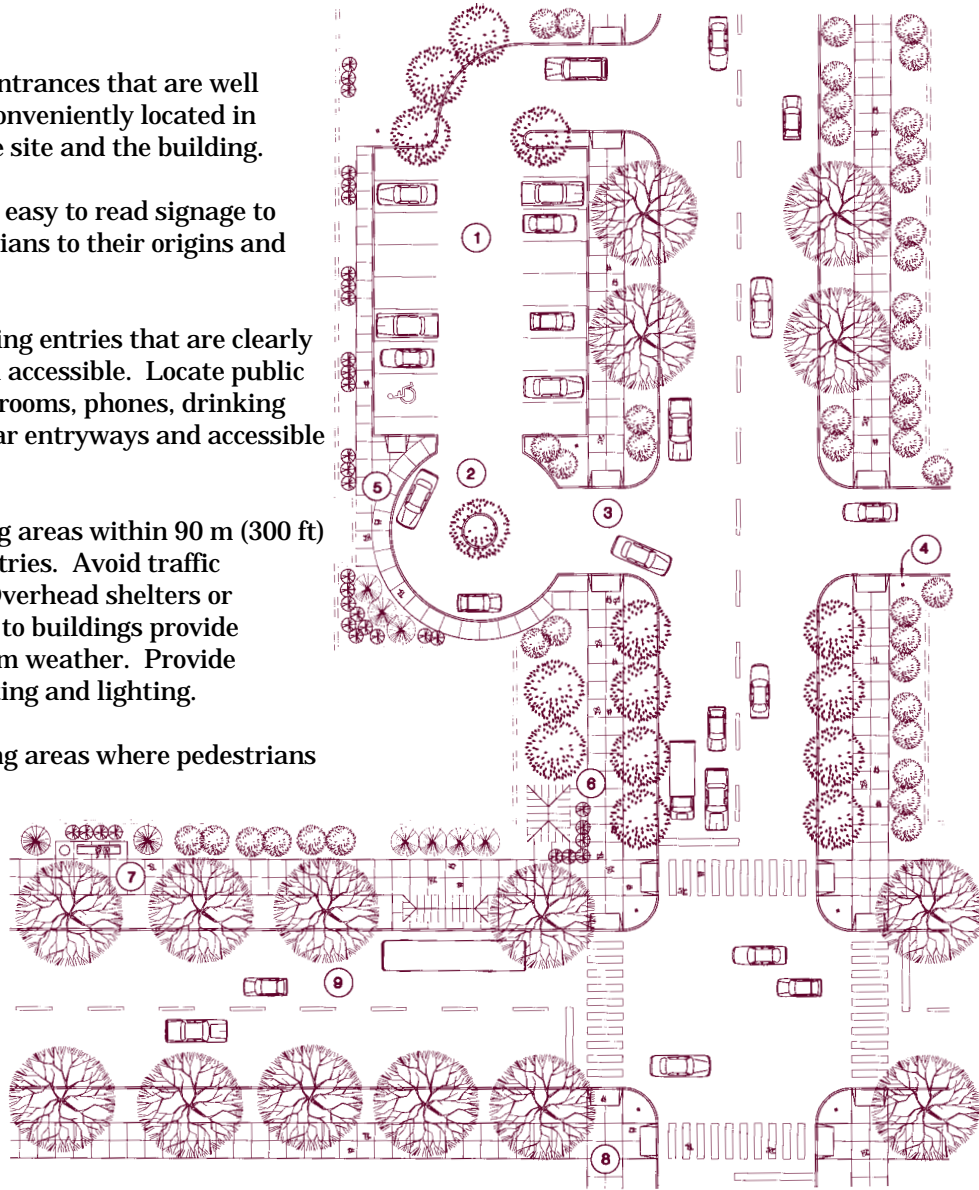

Source: *Time-Saver Standards for Landscape Architecture*, adapted with revisions for this guidebook

Figure 7

- *Facilities for people with mobility and visual impairments, including curb ramps, audible pedestrian signals, and longer intervals for slower pedestrian walking speeds; and*
- *Signing and marking, including pavement edgelines and pedestrian warning signs where needed.”*

Figure 7 on the previous page illustrates an example of how to design effective pedestrian facilities within an area, including some of the features recommended by the *National Bicycling and Walking Study*. Toolkit 10 — Site Design for Pedestrians contains more specific design guidelines related to site development.

Pedestrian Friendly Streets

Design of pedestrian friendly streets is often strongly encouraged by many current planning and design directives at the local and regional levels. The meaning of “pedestrian friendly” can be interpreted in many ways, but generally, the intent is for street design to incorporate elements that enhance the safety, security, comfort, and mobility of pedestrians. Table 18 lists several elements typically included on pedestrian friendly streets.

Typical Elements of Pedestrian Friendly Streets

- Streets that are interconnected and small block patterns provide good opportunities for pedestrian access and mobility
- Narrower streets, scaled down for pedestrians and less conducive to high vehicle speeds (note: street trees at the sides of streets create the perception of a narrower roadway)
- Traffic calming devices to slow traffic (See Toolkit Section 8) or if appropriate, reduced speed limits
- Median refuge islands to provide a refuge area for crossing pedestrians
- Public spaces and pedestrian “pockets” adjacent to the main pedestrian travel way, that provide a place to rest and interact (sidewalk cafes, benches, etc.)
- Awnings/covered building entrances that shelter pedestrians from weather
- Planting buffers, with landscaping and street trees that provide shelter and shade without obstructing sight distances and help to soften the surrounding buildings and hard surfaces
- Street lighting designed to pedestrian scale (shorter light poles with attractive fixtures that are effective in illuminating the pedestrian travel way but not obtrusive or harsh)
- Wide and continuous sidewalks or separated walkways that are fully accessible

Table 18

Typical Elements of Pedestrian Friendly Streets

- Clear delineation and direction for the pedestrian (special paving on sidewalk or at edge of pedestrian travel area, easy-to-reach signal actuators, etc.)
- Lively building faces with architectural relief, windows, or attractive surfacing.
- Street furnishings, such as benches, garbage receptacles, drinking fountains, and newspaper stands, if not placed in the route of travel
- Public art, murals, banners, sculpture pieces and water features
- Colorful planters, holiday lighting and other attractive features
- Signs, information kiosks, maps and other elements to help pedestrians

Table 18 (Continued)

Other Sources of Information

The following sources of information are recommended for general design of pedestrian facilities. Please see the Resource Guide included at the end of this guidebook for complete bibliography information.

Accommodating the Pedestrian, Adapting Towns and Neighborhoods for Walking and Bicycling, Richard K. Untermann

A Guide to Land Use and Public Transportation, The Snohomish County Transportation Authority

City Comforts, How to Build an Urban Village, David Sucher

City, Rediscovering the Center, William H. Whyte

Creating Bicycle-Friendly and Walkable Communities, Pro Bike Pro Walk 96 Resource Book, Bicycle Federation of America, Pedestrian Federation of America

Creating Transportation Choices Through Zoning, A Guide for Snohomish County Communities, The Snohomish County Transportation Authority

Design and Safety of Pedestrian Facilities, A Proposed Recommended Practice of the Institute of Transportation Engineers, ITE Technical Council Committee 5A-5

Handbook for Walkable Communities, Dan Burden and Michael Wallwork, PE

Handbook of Landscape Architectural Construction, Volume Two, Site Works, Maurice Nelischer

Municipal Strategies to Increase Pedestrian Travel, Washington State Energy Office

National Bicycling and Walking Study, Case Study No. 4, Measures to Overcome Impediments to Bicycling and Walking, US Department of Transportation

Pedestrian Malls, Streetscapes, and Urban Spaces, Harvey M. Rubenstein

Pedestrian Planning and Design, John J. Fruin, PhD

1

General Design Guidelines

Planning and Implementing Pedestrian Facilities in Suburban and Developing Rural Areas Research Report 294A, Transportation Research Board

Planning and Implementing Pedestrian Facilities in Suburban and Developing Rural Areas State-of-the-Art Report 294B, Transportation Research Board

Planning Design and Maintenance of Pedestrian Facilities, Goodell-Grivas, Inc.

Site Planning and Community Design for Great Neighborhoods, Frederick D. Jarvis

The Car and the City, 24 Steps to Safe Streets and Healthy Communities, Alan Thein Durning

Time-Saver Standards for Landscape Architecture, Design and Construction Data, Charles W. Harris, Nicholas T. Dines

Walk Tall, A Citizen's Guide to Walkable Communities, Version 1.0, Pedestrian Federation of America

Handbook for Walkable Communities, Washington State Pedestrian Facilities Planning and Design Courses, Dan Burden and Michael Wallwork, PE

WSDOT Design Manual, 1020 Facilities for Nonmotorized Transportation

Accessibility

This Toolkit Section Addresses:

- *Understanding the ADA*
- *Designing for People With Disabilities*
- *Designing for Older Adults*
- *Accessible Routes of Travel*
- *Eliminating Barriers and Obstacles*
- *Widths and Clearances*
- *Passing and Resting Areas*
- *Grades*
- *Cross Slopes*
- *Sidewalk Curb Ramps*
- *Ramps*
- *Handrails*
- *Accessibility Across Driveways*
- *Surfacing*
- *Textural and Visual Cues*
- *Site Connections*
- *Signing and Other Communication Aids*
- *Lighting*
- *Other Sources of Information*



Everyone has an inherent right to accessibility.

Everyone has an inherent right to accessibility. The overall intent of this toolkit section is to encourage design that provides accessibility to all pedestrians, including people with disabilities and older adults. People with physical impairments and older adults have a wide range of abilities and needs, and often rely on pedestrian travel as their only mode of transportation. Just as we design roadways for use by a wide range of vehicles, so should we design sidewalks, walkways, crossings, signals and other types of facilities for use by a wide range of pedestrians. For a description of the spatial requirements and general needs of pedestrians with disabilities and older adults, refer to the section of this guidebook called About Pedestrians.

Understanding the Americans With Disabilities Act

The Americans with Disabilities Act (ADA) is a federal law that was enacted in 1990 for the purpose of ensuring that all Americans have the same basic rights of access to services and facilities. The ADA prohibits discrimination on the basis of disability. To effect this prohibition, the statute required certain designated federal agencies to develop implementing regulations. The Americans with Disabilities Act Accessibility Guidelines (ADAAG) prepared by the Architectural and Transportation Barriers Compliance Board (also called the Access Board) are a result of this rulemaking process. The ADAAG contain a wide range of administrative and procedural

requirements, including compliance with design and construction standards.

The ADA requires pedestrian facilities used by the general public to be planned, designed, constructed and maintained with the understanding that a wide range of people will be using them and relying on them for their daily travel, including people with disabilities. Providing pedestrian facilities that are fully accessible enables people with various degrees of mobility and disability to exercise their rights to become as self-sufficient and independent as possible.

The guidelines and standards contained within the ADAAG are continually being updated and refined, and current versions should be reviewed as part the design process for every project. The ADAAG applies only to new construction and alterations, but other legal requirements of the ADA cover improvements of existing facilities, including removal of barriers in places of public accommodation.

In recent years, much information has been developed to respond to the perceptions planners and designers have about what the ADAAG requires. Some of this information can be confusing and conflicting. The design guidelines in this toolkit section help to clarify the regulations of the ADA as described in the ADAAG and the Washington State Regulations (WAC 51-30), *Accessibility Design for All, An Illustrated Handbook*, published in 1995.

Designing for People With Disabilities

Disabilities include a wide range of conditions (hearing and sight impairments, mobility limitations, heart disease, etc.)

Approximately 70 percent of all Americans will have a disability at some point in their lifetime, either temporarily or permanently (*Accessibility Design for All, An Illustrated Handbook*). Disabilities can affect people differently and limit abilities to greater or lesser degrees. For this reason, some design approaches may accommodate one person but be a barrier to others.

Working closely with people with disabilities in the project design process can be an effective way to ensure that their needs are fully accommodated. The Easter Seal Society of Washington (1-800-678-5708) provides design review and comment services upon request. (There may be a fee associated with reviews by the Easter Seal Society or other groups.) The best guidance design professionals have for accommodating the needs of people with disabilities are the regulations and standards issued under the ADA.

Designing for Older Adults

Often, older adults are avid pedestrians. If retired, senior citizens may have more time to enjoy walking for exercise and recreation. Older adults often rely on walking and transit service to do their daily errands, rather than driving a car, or they sometimes use wheelchairs or motorized carts to travel along pedestrian routes. When walking, they may travel at slower rates and have less mobility or disabilities such as sight or hearing impairments. Many of the same design recommendations for people with disabilities

can be applied to accommodate older adults with these special needs.

Accessible Routes of Travel

The “accessible route of travel” is the key element of accessibility and is defined in Table 19.

The ADA requires every site to have at least one accessible route of travel that provides a connection between exterior accessible site elements (parking, waiting and drop-off zones, sidewalks and walkways, bus stops, etc.) and an accessible building entrance. In a park or similar setting, the accessible route should connect the major features of the site, including parking, drinking fountains, restrooms, interpretive signs and other constructed facilities and points of interest.

Recreational facilities, such as trails, should provide accessible experiences as well. If terrain or other unusual conditions do not allow for the trail to serve as an accessible route of travel, other accessible connections or facilities that provide a similar recreation

Definition of Accessible Route of Travel

A continuous unobstructed path connecting all accessible elements and spaces in an accessible building or facility than can be negotiated by a person using a wheelchair and that is usable by persons with other disabilities (includes access routes across sites between building entrances and other public facilities such as parking, sidewalks, restrooms, etc.)

Source: Accessibility Design for All-An Illustrated Handbook, 1995 Washington State Regulations

Table 19

experience can be created. Figure 8 illustrates a site with alternative routes of travel connecting the building entrance.

Eliminating Barriers and Obstacles

Accessible routes of travel need to be continuous and unobstructed. Obstacles and abrupt changes in elevations create barriers for pedestrians, especially for those with



Older adults often rely on walking and transit service to do their daily errands.



Recreational facilities, including trails, should provide accessible experiences.

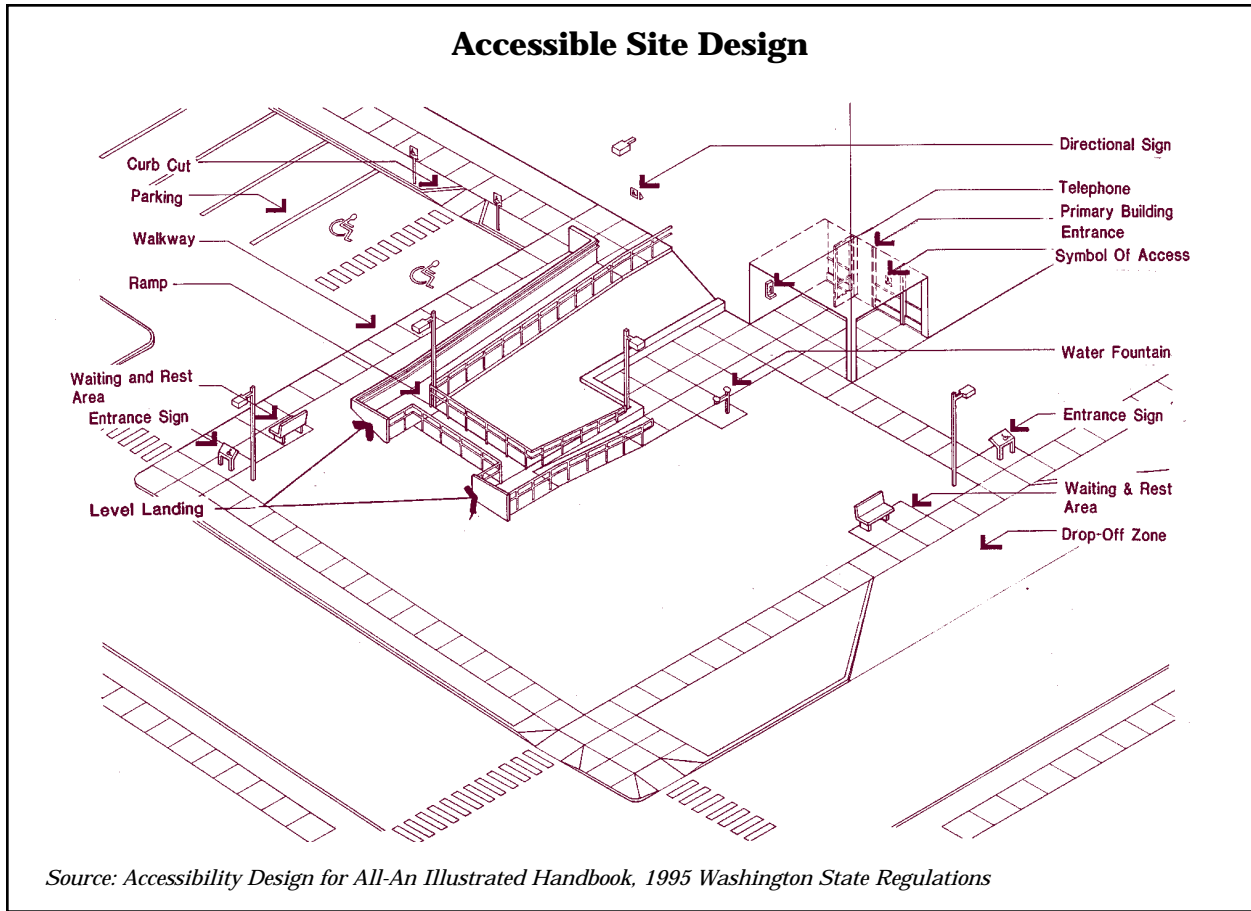

Figure 8

disabilities. Curbs, steps, and stairways create barriers for wheelchair users and other people with disabilities, as well as people pushing strollers or carts. Curb ramps allow access for wheeled devices up onto and down from areas raised and separated by curbs. Where it is not possible or practical to avoid the installation of steps and stairways, ramps or elevators should be provided to facilitate full access. Design guidelines for curb ramps and long ramps are presented later in this section. Design guidelines for steps and stairways are provided in Toolkit Section 10 — Site Design for Pedestrians.

Do not place obstacles such as street furniture, power poles, sign posts and other elements in the route of pedestrian travel. It

is also preferred that there be no grates in a walkway.

Often, coordination between local jurisdictions, private vendors, utility companies and others is necessary to avoid placement of obstacles within the pedestrian travel way after a project is designed and built. Another solution to reducing obstacles within the pedestrian travel way is consolidation of elements, such as placing multiple signs on one post, placing signs on light standard posts and providing a “corral” for trash receptacles, newspaper stands, and other street furniture.

Sidewalk cafes or other displays along an accessible route of travel can become hazards for sight impaired pedestrians or obstructions for wheelchair and stroller users. Enclose these areas with covered railing or fencing that is at least 0.7 meters (27 inches) in height and detectable by canes. Provide a clear path of travel around the outside of these areas.

Widths and Clearances

A clear width of passage, without obstacles such as signs, newspaper stands, and trash receptacles needs to be provided for accessible routes of travel. The ADA requires that pedestrian travel ways have a minimum of 0.9 meters (3 feet) wide to accommodate wheelchairs. All of the 0.9-meter (3-foot) wide space needs to be usable and unobstructed, clear space for wheelchair passage. Obstructions, including handrails, must be located at the edges of this clear zone, not protruding into it. If power poles or other street furniture encroach on the sidewalk or walkway, a minimum 0.9-meter (3-foot) wide passageway must still be maintained. It is best to provide direct routes of travel as well, so that pedestrians don't have to change their course of travel to avoid such obstacles.

The minimum desirable width for sidewalks is 1.5 meters (5 feet) on local neighborhood streets, and 1.8 meters (6 feet) elsewhere, which meets the ADA minimum clear width of 0.9 meters (3 feet). When a walkway of less than 1.5 meters (5 feet) must be installed, passing areas are required as described below.

Vertical clearance is also important to accommodate very tall people and to allow an area free of obstructions that might be

hazardous to people with visual impairments. Accessible routes of travel are required to have a clear height of no less than 2 meters (80 inches). Local requirements may vary; AASHTO recommends a minimum vertical clearance of 2.4 meters (8 feet) minimum. Where the vertical clearance of an area adjacent to an accessible route of travel is impacted by lateral obstructions, a continuous permanent barrier around or at the base of the obstruction is required.

Passing and Resting Areas

Adequate width for wheelchair users is important. It is necessary to provide passing areas for two wheelchairs as well. When an accessible route of travel is less than 1.5 meters (5 feet) wide, passing areas measuring 1.5 meters by 1.5 meters (5 feet by 5 feet) every 60 meters (200 feet) are necessary, as illustrated in Figure 9. Passing areas may already be available at building entrances, plazas, and sidewalk intersections.

Avoid long distances between resting areas for people with lower stamina or health impairments. Strategically and frequently

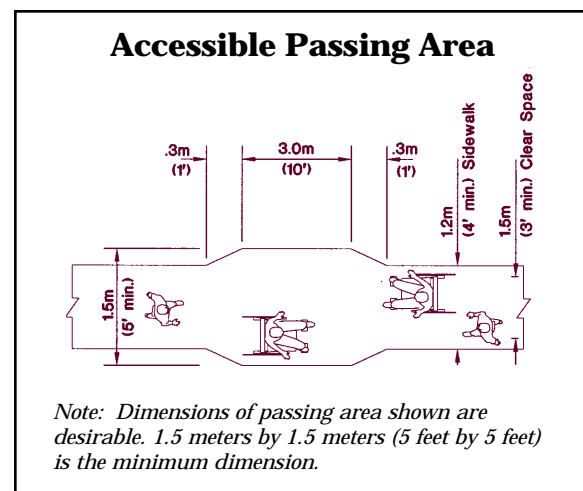

Figure 9

located benches, seating walls, resting posts, railings, restrooms and drinking fountains are examples of elements that can make pedestrian travel more convenient and enjoyable, particularly for those with mobility impairments.

Grades

Accessible routes of travel should not exceed a maximum longitudinal grade of 1:20 or 5 percent. If the grade must exceed this maximum, a ramp can be constructed (see design guidelines for ramps later in this section). Any accessible route of travel is required to not exceed a maximum grade of 1:12 or 8.33 percent. Although, sidewalks and walkways (and trails) located along roadways within the right-of-way may follow the natural grade of the land, which may exceed these maximum gradients (ADAAG). When an accessible route is greater than 1:20 (5 percent), it is considered a ramp and must have handrails and landings.

Landings are generally required at every point in the run of ramped accessible

walkways with a grade exceeding 1:20 (5 percent) if the ramp has a 1:12 (8.33 percent) grade where the elevation change reaches 0.8 meters (30 inches or 2.5 feet), landings are required every 9.1 meters (30 feet), or where there is a change in direction. Landings are not required when the sidewalk or walkway (or trail) is located alongside a roadway that exceeds these maximum gradients. Landings are required to be a minimum of 1.5 meters (5 feet) in length and width, and should be consistent lengths along the route of travel.

In some cases it may be more practical to design a pathway at a lower gradient to minimize the number of landings required (see Figure 10). On multi-use pathways that follow the natural terrain, landings are typically not required by the ADA (WSDOT). Where possible, multi-use pathways should be accessible, but this is not always practical due to topographic conditions and other physical constraints. Landings on these steeper multi-use trails create a choppy effect, are difficult to construct, and are a hindrance to bicycle travel. However, if a pathway is designated as an accessible route of travel, landings and handrails on both sides need to be provided.

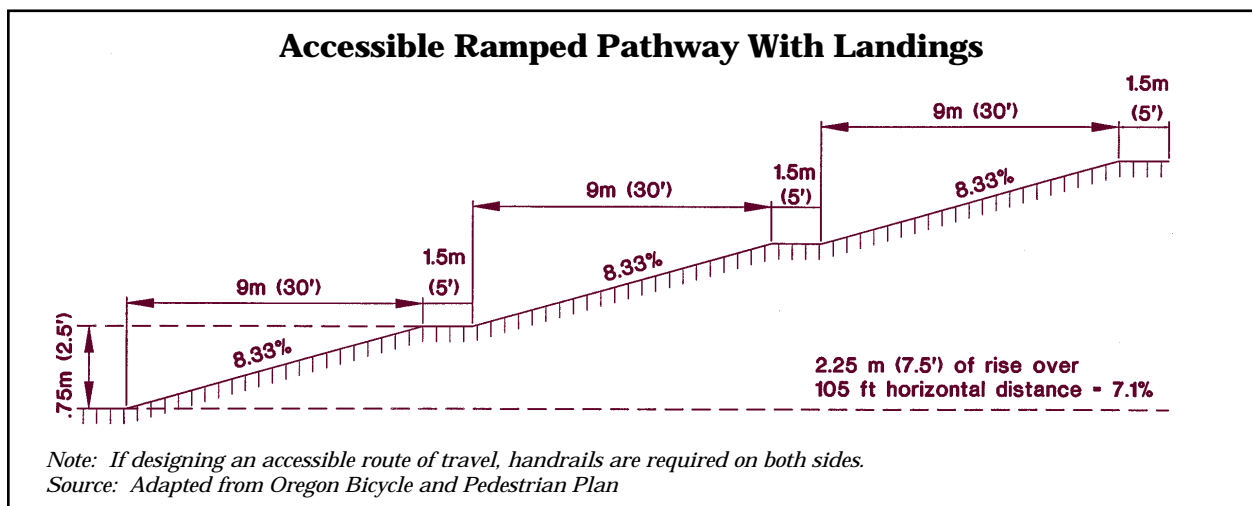

Figure 10

Cross Slopes

Cross slopes on sidewalks and walkways should not exceed 2 percent, but should be of sufficient grade to facilitate positive drainage and avoid water accumulating on the surface. It is difficult to operate a wheelchair along a walkway with a cross slope of greater than 2 percent, because the wheelchair tends to turn toward the direction of the cross slope.

Slopes across intersections and crossings should also not exceed 2 percent, to facilitate crossing by wheelchair users and others. Wheelchair users should not be forced to travel uphill at steeper grades across the street.

Sidewalk Curb Ramps

Design of Sidewalk Curb Ramps

Sidewalk curb ramps provide accessibility at intersections, building entrances and other areas where elevated walkways are edged with curbing. It is recommended that curb ramps have a detectable warning surface, such as an imprint using a metal grid pattern with 1.3 centimeter (.5-inch) spacing, for the full width and depth of the ramp. However, detectable warnings are not currently required by the ADA (the provision has been temporarily suspended) for curb ramps. They are still required at transit platforms. Textural warnings are currently being reviewed by the Access Board. The transition between the edge of the street paving and the curb cut should be smooth, without a lip.

Sidewalk curb ramps are required to be a minimum of 0.9 meters (3 feet) wide, with a maximum grade of 1:12 (8.33 percent) in the

direction of travel, and 1:10 (10 percent) on the side aprons, as long as landing space is provided behind the curb ramp. A minimum 0.9-meter (3-foot) wide passageway/landing area with a maximum 2 percent cross slope is required behind curb ramps. However, a 1.3-meter (4-foot) wide space may be required by some jurisdictions. When this cannot be provided, the side aprons of the curb ramp should not exceed 1:12 (8.33 percent). Curb cuts at street crossings for multi-use pathways should be the full width of the pathway. Figure 11 shows two methods for curb ramp design in detail. Figure 12 illustrates accessible curb ramp design options.

Locations of Sidewalk Curb Ramps at Intersections

Curb ramps are important devices at intersections, not only because they facilitate crossing for wheelchair users, people pushing strollers, bicyclists, and others, but also because they help sight impaired pedestrian to identify the street crossing location. Two curb ramps per corner at intersections are recommended for new construction, one in the direction of each crosswalk (see Figure 13). One curb cut at each corner point may direct pedestrians out into the center of the intersection into an opposing traffic lane, rather than toward the crosswalk, or introduce a pedestrian at a point where drivers are not anticipating a pedestrian, especially when turning. Consider these points when selecting a curb ramp design.

Table 20 lists important things to remember when designing curb cuts at intersections.

Accessible Curb Ramp Design Details

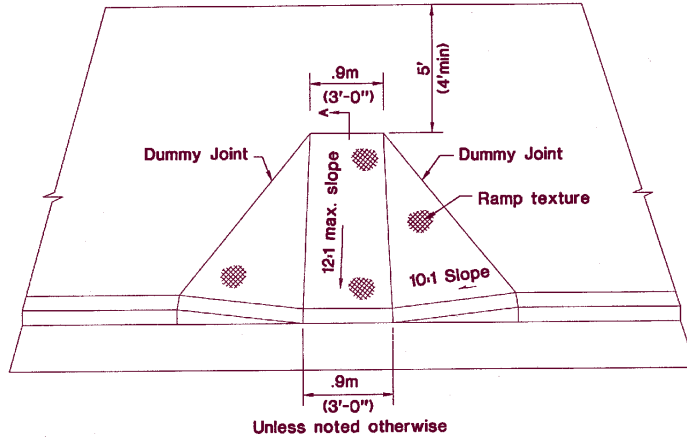

Unless noted otherwise

NOTES:

1. Ramp and approaches shall be clear of obstacles incl. hydrants, poles, and inlets.
2. Ramp shall be textured by imprint of metal grid with 1.3cm (1/2") spacing.
3. Ramp center line shall be perpendicular to or radial to curb returns unless otherwise approved by engineer.

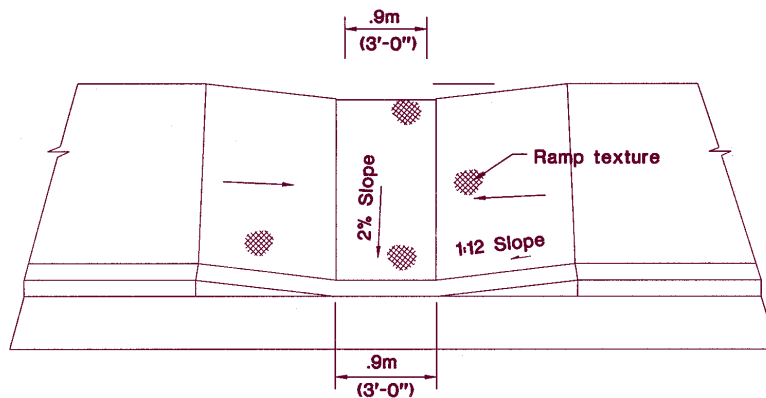
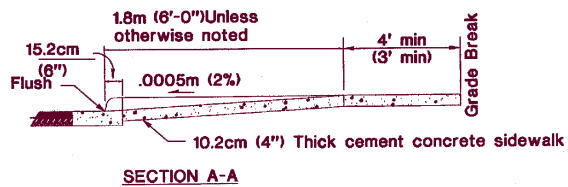

Unless noted otherwise

NOTES:

1. Ramp and approaches shall be clear of obstacles incl. hydrants, poles, and inlets.
2. Ramp shall be textured by imprint of metal grid with 1.3cm (1/2") spacing.
3. Ramp center line shall be perpendicular to or radial to curb returns unless otherwise approved by engineer.

Source: WSDOT Design Manual and other sources, adapted for this guidebook

Figure 11

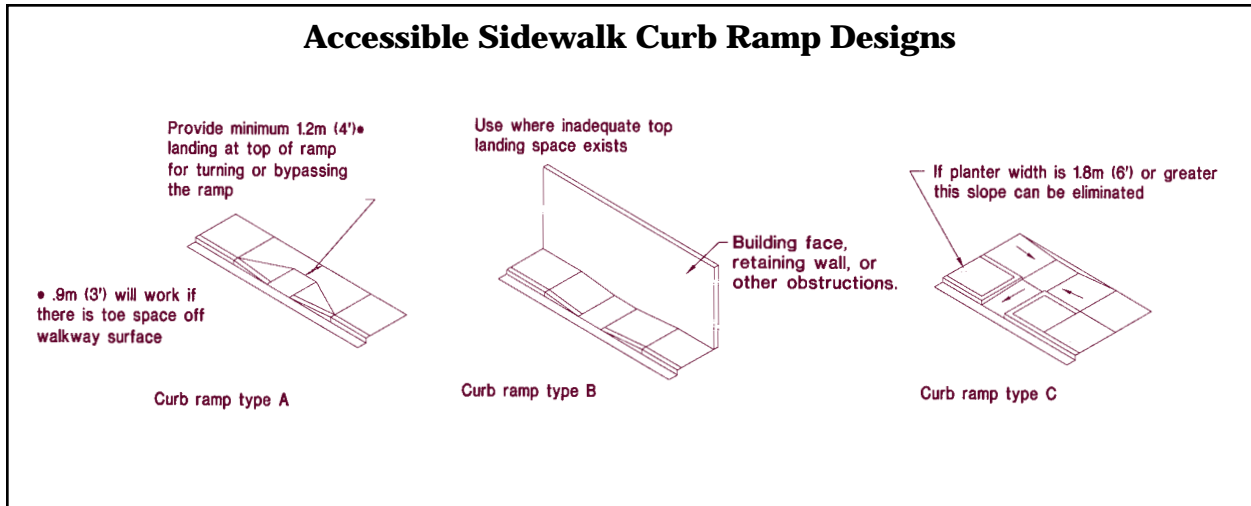

Figure 12

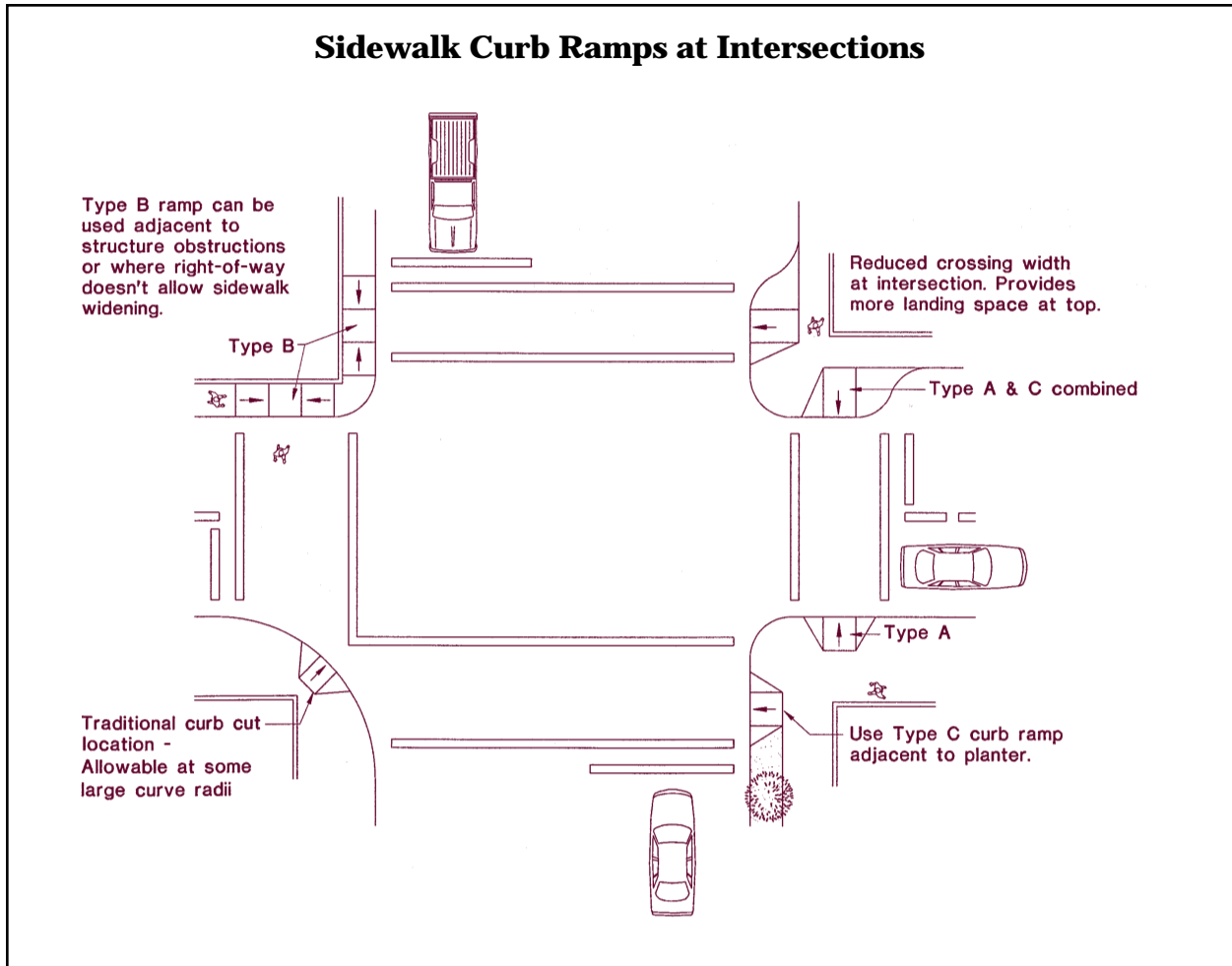

Figure 13

Important Things to Remember About Curb Cuts at Intersections

- Curb cuts should align in the direction of crosswalks, with two per corner at each intersection and at right angles to the curb
- Curb cuts function best when located in the center of the crosswalk; or as an alternative, can be constructed to be as wide as the approaching walkway
- The low end of the curb cut should meet the grade of the street with a smooth transition, without a lip
- Curb cuts should also be provided at channelization islands in an intersection and median refuge islands, unless full cut-through openings are provided at grade with the street
- Good drainage at intersection corners is important so that standing water does not accumulate within the crossing area. Storm drainage inlets should be placed on the uphill side of crosswalks and outside of the

Table 20

Ramps

Providing accessibility along walkways and across sites with significant changes in elevation is sometimes challenging. Ramps allow accessibility where grades exceed 1:20 or 5 percent. Table 21 summarizes the ADA requirements for ramps.

In general, ramp design should incorporate the following:

- Maximum longitudinal grade of 1:12 or 8.33 percent

ADA Requirements for Ramps

- The maximum rise for any run shall be 760 mm (30 inches)
- Ramps shall have level landings at the bottom and top of each ramp and each ramp run

Note: See the ADA accessibility guidelines for additional information.

Source:

Table 21

- Minimum width of 1.1 meters (44 inches) for exterior ramps, with a minimum clear space of 0.9 meters (36 inches) between handrails
- Level landings at the top and bottom of the ramp and at changes in direction
- Intermediate landings for every 0.8 meters (30 inches) of vertical elevation change; every 9.1 meters (30 feet) of 8.33 percent run
- Handrails for walkways and pathways steeper than 1:20 (see design guidelines later in this section)
- Maximum cross slope of 2 percent and sufficient to provide positive drainage
- Edge protection for ramps steeper than 1:20 or landings more than 1.3 centimeters ($\frac{1}{2}$ -inch) above the adjacent grade. Edge protection may include low walls or curbs

not less than 5 centimeters (2 inches) high, and guardrails when necessary

Landings on Ramps

Where a ramp changes direction, landings need to be 1.5 meters (5 feet) wide by 1.5 meters (5 feet) long. Landings always need to be at least as wide as the width of the ramp.

Exceptions to Maximum Grades of Ramps

Curb ramps and other short ramps constructed on existing developed sites may have slopes and rises greater than those allowed by the ADA where space limitations preclude the retrofit of 1:12 slopes or less, provided that:

- A slope not greater than 1:10 (10 percent) is allowed for a maximum rise of 152 mm (6 inches)
- A slope not greater than 1:8 (12.5 percent) is allowed for a maximum rise of 76 mm (3 inches)
- Slopes greater than 1:8 (12.5 percent) are not usable by many

Handrails

Accessible routes having grades steeper than 1:20 (5 percent) shall have handrails on both sides. Handrails shall extend at least 30 cm (12 inches) beyond the top and bottom of any ramp run (see Figure 14). The top of the handrail is required to be 86 to 96 cm (34 to 38 inches) above the grade of the walkway or ramp. An intermediate handrail may be mounted at a height of 43 to 48 cm (17 to 19 inches) or a handrail with vertical rail

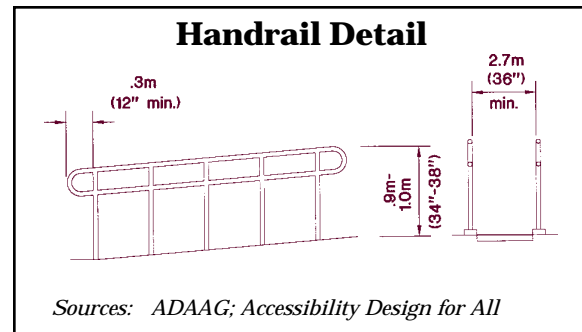

Figure 14

members spaced not more than 10 cm (4 inches) apart to aid those in wheelchairs.

Handrails are required to be continuous unless there is a point of access along the ramp that requires a break in the handrail. Handrails should be continuous through the landings for the entire length of the ramp system.

Handrails are not required for sidewalk curb ramps, and are generally not recommended alongside multi-use pathways since they could become a hazard to bicyclists (unless the pathway is specifically designated as an accessible route of travel).

Accessibility Across Driveways

As a general rule, it is best to minimize the number of driveway crossings across an accessible route of pedestrian travel. When the sidewalk across the driveway crossing is an accessible route of travel, special design requirements need to be applied.

The traditional approach to accommodating driveway cuts in sidewalks has changed due to accessibility requirements. The past method of driveway installation across sidewalks results in a 10 percent cross slope for a 1.5-meter (5-foot) wide sidewalk (see

Figure 15). This creates difficult-to-maneuver driveway aprons in the path of travel and can be a major impediment to sidewalk usability.

There are four basic approaches to designing driveway cuts that meet the ADA requirements. These are illustrated in Figures 16, 17, 18, and 19. The most important element of these solutions is that they provide a continuous route of travel that is a minimum 0.9 meters (3 feet) in width with a cross slope not exceeding 2 percent. Refer to the WSDOT *Standard Plans* for related design standards.

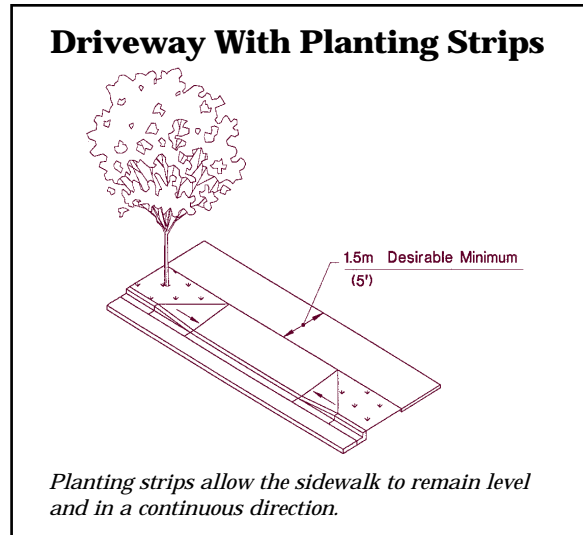

Figure 17

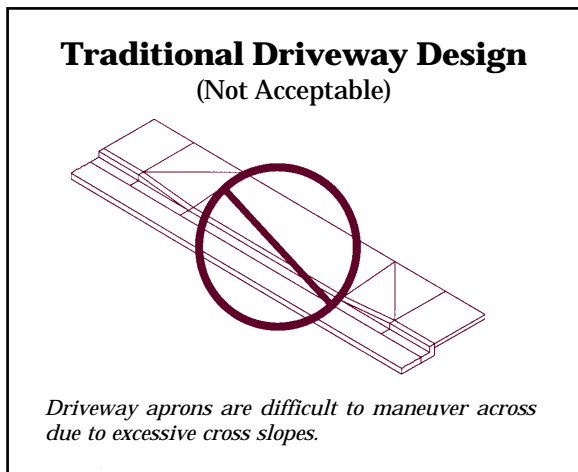

Figure 15

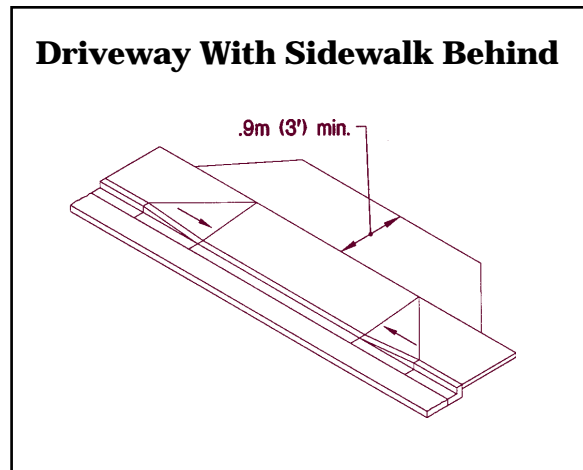

Figure 18

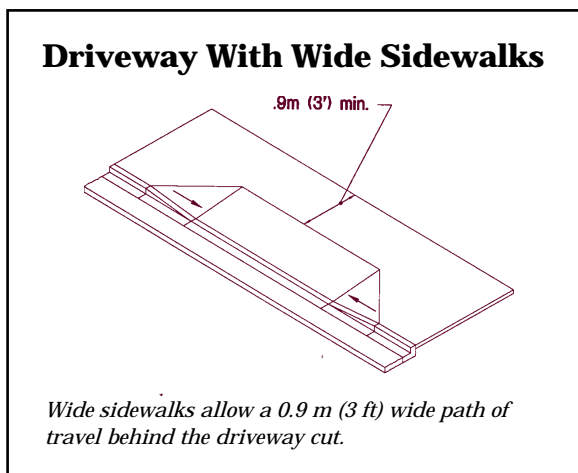

Figure 16

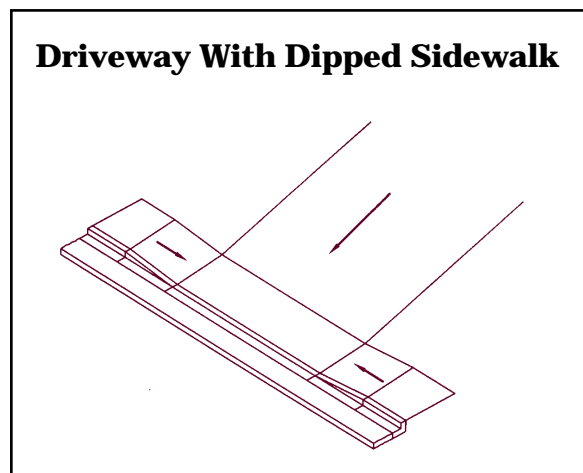

Figure 19

Where constraints don't allow a planting strip or wider sidewalks, the sidewalk can be wrapped around the upper end of the driveway cut. (Note: this method may be difficult for sight-impaired who follow the curb line for guidance, but this can be helped by providing a substantial lip at the edge of the driveway along the road edge.)

This approach dips the sidewalk in the direction of travel, keeping the cross slope at a constant grade. The problems with this approach are that pedestrians must maneuver up and down the sidewalk grade change and drainage may accumulate in the sidewalk area. A prominent lip at the edge of the driveway can help to resolve the drainage problem.

Surfacing

The surface of a walkway must be firm and stable enough to support the higher point loads of wheelchair wheels, crutch tips and other mobility aids. Pavement is typically the most practical means of meeting this requirement. Smooth pavement surfaces are the most desirable, such as portland cement concrete or asphaltic concrete. Unit pavers can also provide a stable surface as long as the joints between paving units are smooth and level. Sometimes, scoring patterns and unit paving patterns can create irregular surfaces that compromise wheelchair stability and control, or that create barriers for ambulatory pedestrians who have gait impairments. Architectural style and appearance should always be balanced with the importance of accessibility. Surface materials should be chosen to avoid creating slippery conditions for pedestrians. Exposed aggregate concrete surfaces accumulate moisture which can freeze and create icy

conditions on sidewalks if not maintained properly.

Compacted crushed rock surfaces and consolidated soils are less desirable and may not be acceptable for accessible routes of travel without extensive maintenance to ensure rollability and maneuverability. However, in some cases this type of surfacing may be a suitable solution in outdoor recreation areas to make walkways and trails more accessible to all (see Toolkit Section 4 — Pathways, which addresses accessibility considerations for recreational trails). Compact crushed rock surfaces into a smooth condition without loose rocks, bumps or grooves. Loose gravel, such as pea gravel and most types of wood chip surfacing are generally not acceptable as accessible surfaces.

Textural and Visual Cues

People with sight impairments need cues as they travel through a pedestrian system. If their meaning is understood, textural changes in the surface of the walkway when changes occur in the route of travel can serve as a tactile cue for persons who have low vision or are blind. Textured surfaces at street crossings, building entrances, bottoms and tops of stairways and ramps, and across curb ramps are examples. Figure 20 illustrates textural cues.

Other elements can be strategically placed along accessible routes to identify ramps, building entrances, pathway intersections, etc. Such elements include lighting, change in landscaping, signs, and changes in pavement patterns or colors. The Access Board is currently studying the effectiveness of various tactile cues.

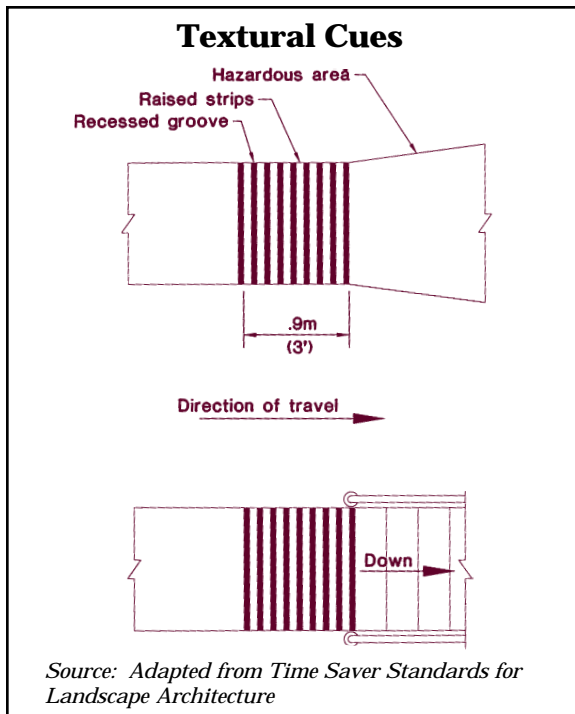

Figure 20

Site Connections

At least one accessible route of travel is required by the ADA on sites to connect primary building entrances with accessible site facilities such as parking areas, bus drop-off zones, and public services such as telephones and drinking fountains. Accessible routes of travel need to be designed in accordance with the requirements for walkways described above, including the maximum cross slope and grade requirements.

The route between accessible parking spaces and the building entrance must be carefully planned to minimize the distance that must be travelled by a disabled person and to ensure that obstacles and hazards are avoided. It is recommended that the

maximum distance be no greater than 30 meters (100 feet).

Signing and Other Communication Aids

Signing is an essential aid to negotiation for all pedestrians, including older adults and people with disabilities. Signing identifies nearby services, warns of possible hazards, and directs people to their destinations. Signs should be readily observable, with clear and precise information. Place directional signage at decision points where access provisions are not obvious to indicate the location of accessible parking spaces, building entrances, and restrooms. Redundancy is desirable for significant safety and directional information.

For the sight-impaired, Braille strips can be added to the edges of signs that are reachable and located for that purpose. Raised or routed letters may be desirable since not all sight-impaired people are able to read Braille. Audible systems in the pedestrian environment are being experimented with across the country and in other nations. Audible messages, chirping devices, click, and tones can be strategically located to warn sight-impaired pedestrians of condition along a route, particularly at street crossings, or to notify them of important information (at kiosks and bus depots). One example includes chirping devices being placed with traffic signals at crosswalks to notify pedestrians when the crossing phase has been activated. Push buttons at signal locations need to be installed at heights easy to reach by people in wheelchairs.

Lighting

Lighting is required along exterior accessible routes of travel during any time the buildings on site are occupied. Lighting is to have a minimum intensity of one footcandle on the surface of the route.

Table 22 summarizes the ADA requirements presented in this toolkit section. ***All of the standards described throughout this section are required by the federal and state governments as part of compliance with the ADA, unless otherwise noted as recommendations (rather than requirements.)***

Summary of Accessibility Requirements

- Eliminate obstacles within the accessible route of travel
- .9 m (3 ft) clear width absolute minimum; 1.5 m (5 ft) width desirable minimum for accessible
- 1.5 m (5 ft) wide passing areas every 60 m (200 ft) on accessible routes less than 1.5 m (5 ft) in width
- Maximum 1:20 (5%) grade is desirable, steeper grades up to 1:12 (8.33%) can be provided with ramps
- Level landing areas, 1.5 m (5 ft) in length for every 0.8 m (30 in) of elevation change along 1:12 (8.33%) grade (ramps)

Table 22

Other Sources of Information

The following sources of information are recommended for design of accessible pedestrian facilities. Please see the Resource Guide included at the end of this guidebook for complete bibliography information.

Accessibility Design for All, An Illustrated Handbook, 1995 Washington State Regulations, Barbara L. Allan and Frank C. Moffett, AIA, PE

Americans With Disabilities Act (ADA) Accessibility Guidelines for Buildings and Facilities; State and Local Government Facilities; Interim Final Rule, Federal Register, Part II, Architectural and Transportation Barriers Compliance Board

Recommendations for Accessibility Guidelines: Recreational Facilities and Outdoor Developed Areas, Recreation Access Advisory Committee

Uniform Building Code (and state and local building codes)

Universal Access to Outdoor Recreation: A Design Guide, PLAI, Inc.

Contacts

Allan, Barbara L., Easter Seal Society of Washington, 521 2nd Avenue W, Seattle, Washington, 98119, (800) 678-5708.

Thibault, Lois E., US Architectural and Transportation Barriers Compliance Board (Access Board), 1331 F Street NE, Suite 1000, Washington, DC, 20004-1111, (202) 272-5434 ext 32, e-mail thibault@access-board.gov.

Children and School Zones

This Toolkit Section Addresses:

- *Special Considerations Related to Children*
- *Improving Student Pedestrian Safety — A Cooperative Process*
- *School Related Pedestrian Improvements*
- *The School as a Community Focal Point*
- *Pedestrian Friendly Schools and School Zones*
- *Traffic Control and Crossings Near Schools*
- *School Walk Routes and Safety Programs*
- *Ongoing Maintenance*
- *Other Sources of Information*

The potentially severe, and often fatal, consequences of a collision between a moving vehicle and a child raises high emotions whenever the topic is discussed. Children are more vulnerable than adults to collisions with motor vehicles, because their movements are often unpredictable. Traffic engineering approaches must fully address concerns about the safety of young children walking along or crossing busy streets and highways to schools, parks, neighbors' houses, or between other origins and destinations in our communities. Table 23 lists common types of pedestrian/motor vehicle collisions involving young children.



Children have the right to travel safely as pedestrians, just as we all do.

Most Common Types of Pedestrian/Motor Vehicle Collisions for Children Aged K-6

- Darting out
- Dashing across an intersection
- Crossing in front of a turning vehicle
- Crossing a multi-lane street
- Entering or crossing an intersection
- Playing in a roadway
- Going to or from a school bus
- Crossing behind a vehicle that is backing up

Source: A Guidebook for Student Pedestrian Safety; as adapted and expanded with input from the Advisory Group.

Table 23

Special Considerations Related to Children

Collision statistics and other information related to children are provided in the section of this guidebook called About Pedestrians. As pedestrians, children are exposed to more collisions for several reasons. One of the most problematic characteristics of child pedestrians is that their movements are less predictable than adults. Young children tend to dart-out into traffic or cross the street without looking for oncoming traffic more often than adults. Young children also lack the visual acuity and peripheral vision to judge speeds of oncoming traffic and adequacy of gaps in the flow of traffic (Knoblauch, et al). Since children do not drive, they lack the understanding of what a driver's intentions might be at an intersection or crossing point. Table 24 lists the special limitations of children aged five to nine.

It's important to remember the special limitations of this age group when designing for them. Research has shown that adults uniformly tend to overestimate a child's capabilities to deal with traffic, particularly when crossing the street. Adults sometimes fail to realize that many children under age nine lack the developmental skills to safely and consistently cope with moving traffic.



It's important to remember the special limitations of young children when designing for them.

Some Special Limitations of Children Aged 5 to 9

- Children are shorter than adults; typical eye height is 1 meter (3 feet) above ground; their field of vision is different.
- Children have one-third narrower side vision than adults and are less able to determine the direction of sounds.
- Children have trouble judging speeds and distances of moving cars.
- Children are sometimes too small to be seen by fast moving or inattentive drivers.
- The movements of children are less predictable than adults.
- Children have shorter attention spans and may grow impatient at crossings.
- Children have less experience as pedestrians and may not be fully aware of dangerous conditions.

Source: A Guidebook for Student Pedestrian Safety; revised and expanded with input from the Advisory Group

Table 24

Improving Student Pedestrian Safety – A Cooperative Process

The safety of students walking to and from school is a major concern of parents, teachers, schools, public works, law enforcement, and the general community. Since 1982, when Washington state began funding student transportation, school districts have been responsible for deciding which students walk to school and which ride the school bus. School districts are required by law (WAC 392-151-025) to develop walk routes for students

who walk to school, usually those living within a 1.6-kilometer (1-mile) radius of their school. The basics about developing school walk routes are described later in this toolkit section. The responsibility for student pedestrian safety goes beyond development of “safe walk routes” by school districts. Preparing walk route plans is only part of the overall process (see Table 25).

Identifying problems and implementing improvements to address these problems in school zones and along school walk routes require a cooperative effort among public agencies (capital investments and public works funding programs), school districts, private developers, and others in the community to ensure maximum success. All of these entities must work together and coordinate with each other to develop pedestrian improvement programs that provide better opportunities for children to walk to school.

In 1995, the state renewed its emphasis of schools working with the public works agencies to mitigate walk route deficiencies. The legislature reasoned that if hazardous

walking conditions were to be improved by public works agencies, more students would walk to school, reducing ever-escalating transportation costs and at the same time making walkways safer for the community at large.

School Related Pedestrian Improvements

There are two key components of a pedestrian improvement program that ensure safer conditions for school children:

- A sufficient level of physical facilities provided along the school walking route and adjacent to the school (responsibility: local jurisdiction, school district, and private development)
- Effective operation plans and safety programs, consisting of supervisory control elements and student/adult education for school trip safety (responsibility: school district, parents, and general community)

This toolkit section focuses on design recommendations for physical facilities surrounding and at the school site and along school walk routes. Some information related to school walk route and safety programs is provided at the end of this section. *A Guidebook for Student Pedestrian Safety*, prepared for the Washington State Department of Transportation (WSDOT), by KJS Associates, Inc., is a comprehensive resource for development of student pedestrian safety operation plans and walk route programs. Please refer to this document for more detailed information.

Process for Improving Student Pedestrian Safety

- Prepare school walk route plans
- Provide school walk route maps and information to parents and students
- Identify pedestrian safety deficiencies
- Implement remedial actions and improvements to address pedestrian safety concerns

Source: A Guidebook for Student Pedestrian Safety

Table 25



On roadways without sidewalks, but with adequate shoulders, children should be encouraged to walk on the left shoulder, facing oncoming traffic.

The School as a Community Focal Point

A broader consideration related to the design of pedestrian access to schools is how the school is oriented within the community and connected to surrounding neighborhoods.

Schools are often a focal point of the community, serving as much more than a place of education by providing outdoor fields and facilities for play, recreation, meeting, voting, and other community services. Siting a school so it can be easily reached from all directions and providing a sufficient level of pedestrian facilities in the vicinity of the school further help to establish it as a strong component of the community.

School sites should be centered in the community and accessible to pedestrians from all sides. Schools can function both as neighborhood parks and school playgrounds. Streets leading to the school site should be designed to include full sidewalk or walkway improvements and other elements that contribute to pedestrian safety and comfort (traffic calming to slow traffic, good lighting, clear visibility, and trees for shelter and shade). Intersections and crossings within the vicinity of the school need to be well

The School as a Community Focal Point	
<ul style="list-style-type: none"> • The school site is centrally located in the community; most children live within 1.6 km (1 mile). • Pedestrian and bicycle access is available from all directions. • Sidewalks, bike lanes, and trails on adjacent streets or through neighborhoods connect to the school property. • Linkages between surrounding neighborhoods, such as access between cul-de-sacs, provide enhanced pedestrian connections to the school. 	<ul style="list-style-type: none"> • Effective traffic control devices are provided within the surrounding vicinity. • A school walk route and safety program exists and safety patrols are provided within the vicinity. • School facilities, including the playground, fields, and meeting rooms, are available for community use. • Because of the level of pedestrian improvements in the area and the design of the school site, children and adults feel comfortable walking to the school rather than riding the school bus or driving cars.

Table 26

designed, with a focus on the needs of student pedestrians. Table 26 lists important elements of a school as a focal point within the community.

Pedestrian Friendly Schools and School Zones

School sites and surrounding areas should be designed to invite pedestrian travel while also improving pedestrian safety.

School Site Design

Design and retrofit of schools and school grounds requires consideration of many factors, too numerous to list in this guidebook, but some of the basic principles of good school site design related to pedestrian travel are provided below. Specific sites may have unique conditions that require special design treatments. Good design solutions are typically based on the adopted standards and practices of the local jurisdiction, but design solutions can also exceed established standards where desired or necessary to provide a more effective pedestrian system.

Elements of Good School Site Design

- Surrounding streets are equipped with sidewalks and bike lanes.
- The building is accessible to pedestrians from all sides (or at least, from all sides with entries/exits).
- Trails and pathways provide direct links between the school site and the surrounding neighborhoods.
- Bus drop-off zones are separated from auto drop-off zones to minimize confusion and conflicts.
- Buses, cars, bicycles and pedestrians are separated and provided with their own designated areas for traveling.
- Pedestrian travel zones (sidewalks, etc.) are clearly delineated from other modes of traffic (through the use of striping, colored and/or textured pavement, signing and other methods).
- Parking is minimized; people are encouraged to walk to school.
- Pedestrians are clearly directed to crossing points and pedestrian access ways by directional signing, fencing, bollards or other elements.
- Strategically located, well-delineated crossing opportunities are provided, including marked crosswalks at controlled intersections and mid-block crossings (signalized if warranted).
- Traffic calming devices (raised crossings, refuge islands, bulb-outs at crossings, on-street parking, traffic circles, landscaping, etc.) are installed in the vicinity to slow vehicles.
- View obstructions are avoided so there is clear visibility of pedestrians throughout the area.

Table 27

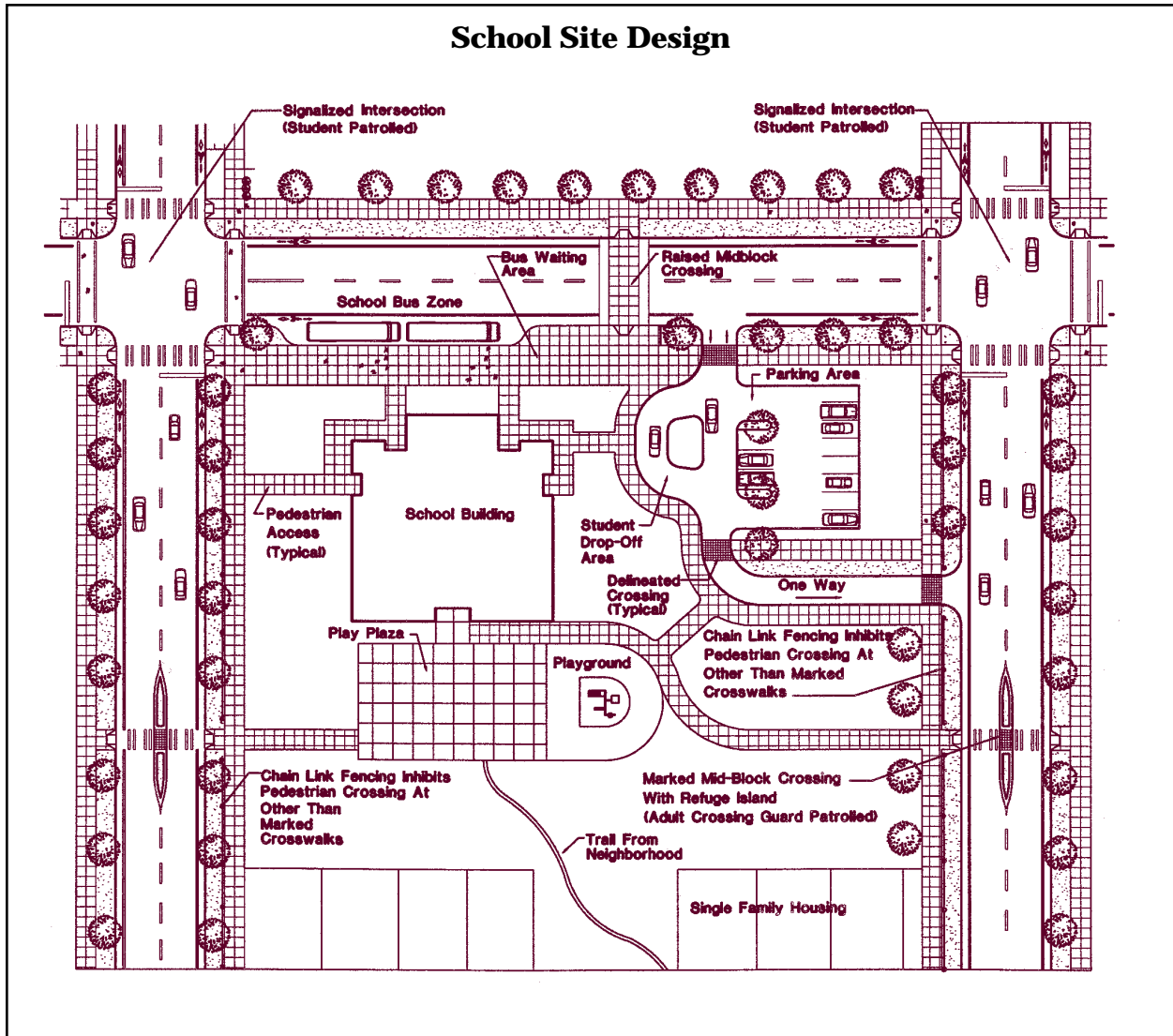

Figure 21

Table 27 lists a few of the typical elements on and adjacent to school sites that function well for pedestrians and encourage pedestrian travel.

Figure 21 illustrates a typical school site design that includes many of these features.

Pedestrian Access Routes to the School

Sidewalks and walkways that clearly define the routes of access to and from schools should

be provided in all areas surrounding the school and on the school site. Vertical separation (with curbs) and horizontal separation (planting buffers, ditches, or swales) from motor vehicle traffic are strongly encouraged to improve the safety of pedestrians walking along streets. Typical roadside improvements that may be suitable for pedestrian travel under varying circumstances are listed in Table 28. Figures 22 and 23 illustrate typical roadside facilities.

Roadside Pedestrian Improvements Along School Walk Routes

- Well compacted crushed rock or gravel shoulders *(recommended as an interim solution only; if an accessible route of travel, surface needs to be smooth and stable)*
- Separated crushed rock or gravel path *(recommended as an interim solution only; if an accessible route of travel, edge treatment is necessary)*
- Paved shoulder *(recommended as an interim solution only; if an accessible route of travel, edge treatment is necessary)*
- Paved walkway or sidewalk separated from roadway by ditches, swales, or planting buffer *(good long-term solution; often used in rural and residential areas; 5-ft. minimum separation recommended)*
- Adjacent sidewalk with curb and gutter or vertical curb *(good long-term solution; often used in urban areas)*

Source: *A Guidebook for Student Pedestrian Safety*; revised and expanded for this Guidebook

Table 28

On roads without sidewalks (often the case in rural areas surrounding schools), widened roadway shoulders accommodate pedestrians. Shoulders may be paved or unpaved, but if unpaved, a well compacted stable surface of crushed rock or other material is highly recommended. At a minimum, *A Guidebook for Student Pedestrian Safety* recommends that shoulders that are part of a designated school walk route be 1.5 meters (5 feet) wide and be provided on both sides. If a shoulder can only be provided on one side, provide a minimum of 2.4 meters (8 feet) in width to allow students to walk off the roadway in either direction. Although this is not the most desirable solution (shoulder on only one side),

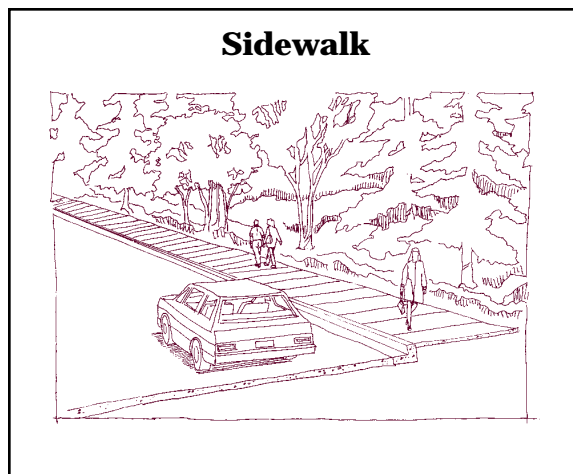

Figure 22

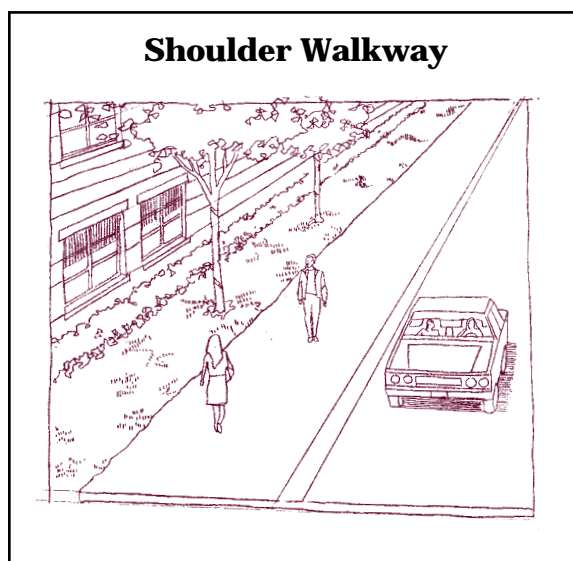

Figure 23

it is better than a scenario where there are no pedestrian travel areas at the roadside. This guidebook recommends that shoulder use for pedestrian travel be considered as only an interim solution until separated walkways or sidewalks can be developed along roadways leading to the school.

Design standards for shoulders vary among jurisdictions. Check with your local agency for specific standards that may be applicable to your project. For more information related to



Students need to be able to travel safely to and from the bus stop.

the design of sidewalks, walkways, and shoulders, refer to Toolkit Section 5. Along roads with adequate shoulders, children should be generally directed to walk on the left shoulder facing oncoming traffic. However, children may be allowed to walk on the shoulder on the side with the flow of traffic for a short distance to or from school if such action reduces the number of road crossings they must make (*A Guidebook for Student Pedestrian Safety*, based on

interpretation of Revised Code of Washington (RCW) 46.61.250 Pedestrians on Roadways).

School Bus Stop Design

Bus stops need to be adequately designed to provide sufficient waiting area away from the roadway for the number children using the stop. In urban areas, bus stops are often designed and constructed as part of private development projects. In rural areas, bus stop locations often consist of a widened shoulder area adjacent to the roadway. Figures 24 and 25 illustrate two typical designs for school bus stops — one for areas where sidewalk either exists or can be constructed, and one for areas where widened shoulders function as the pedestrian travel zone. Check with your local agency and school district for specific design practices that may be applicable in your area.

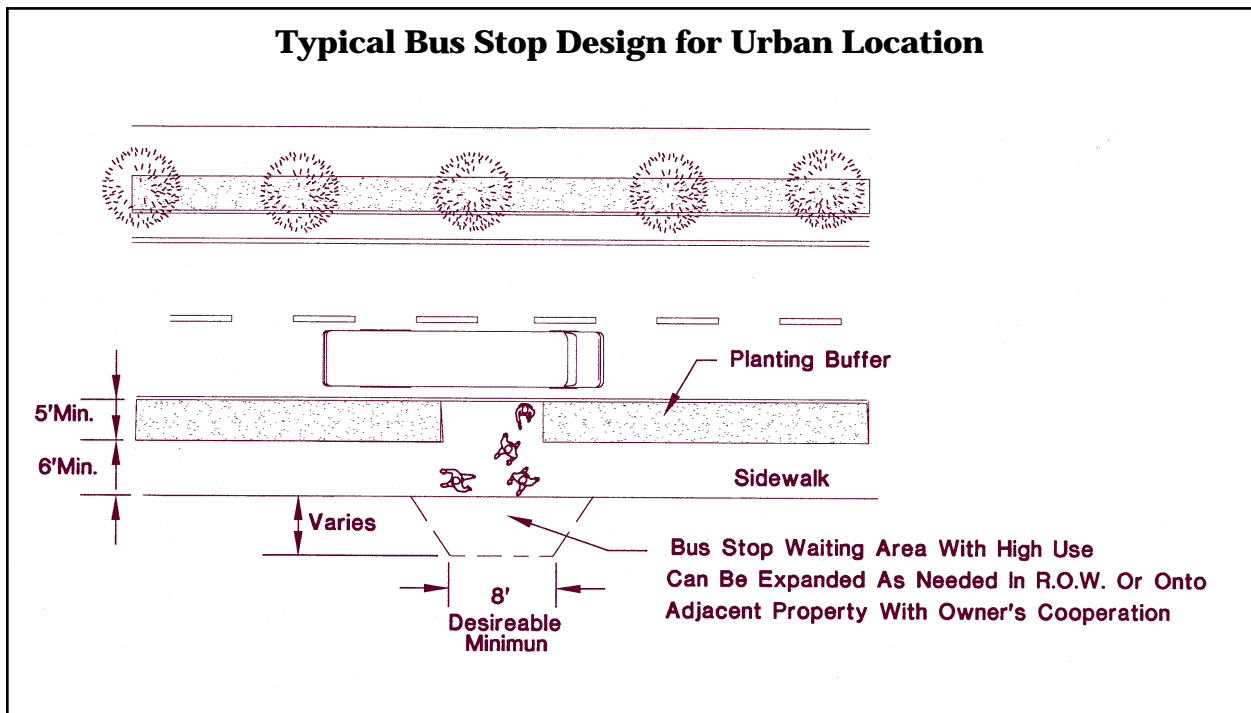

Figure 24

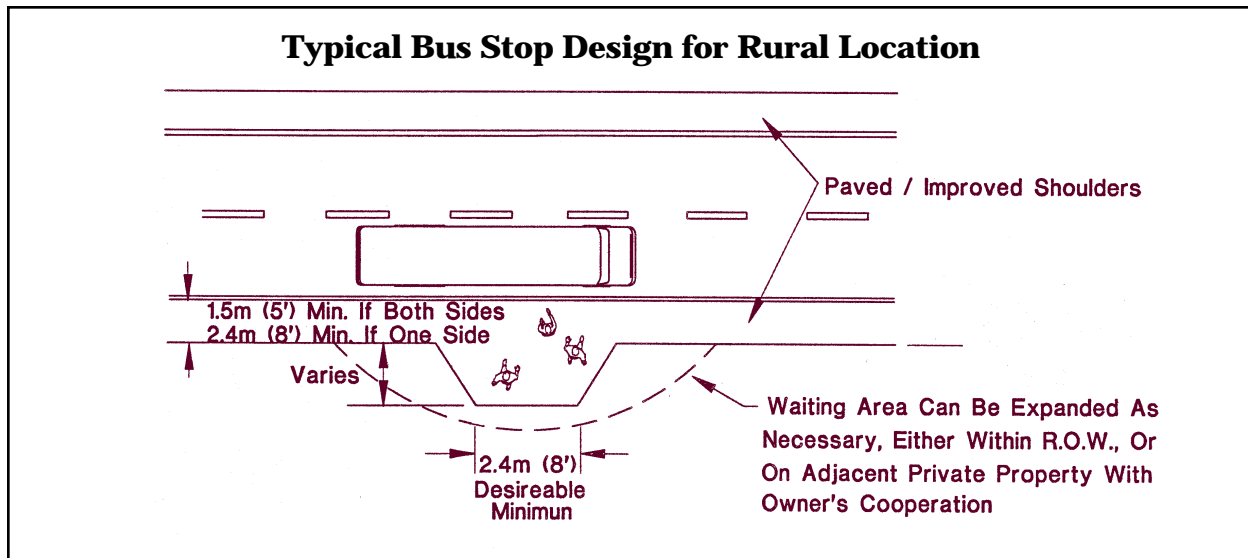

Figure 25

Visibility at Crossings and Along School Walk Routes

Children are smaller than adults and more difficult for motorists to see at crossings. To function safely, crossings should provide an unobstructed visual field between motorists and pedestrians. Street furniture, such as utility poles, mailboxes, and telephone booths should not hide the pedestrian from view. Landscaping can enhance the pedestrian environment and trees can provide shade and shelter from wind and weather. Care must be taken to select lower growing shrubs that won't block views of pedestrian. A maximum shrub height of 0.6 meters (2 feet) is suggested for school zones. Trees along streets should be upward branching, with lower branches located at least 1.8 meters (6 feet) above ground.

Parked vehicles (even momentarily) are also visual obstructions, especially for children, wheelchair users, and people of small stature. For recommended setbacks for parked vehicles near pedestrian crossing points, refer to Toolkit 6 — Intersections.

Traffic Control and Crossings Near Schools

Special considerations related to various types of crossings and traffic control methods used near schools are described in the next part of this section of the guidebook. More specific design information related to traffic control and crossing treatments can be found in Toolkits 6, 7, and 8.

General Considerations

Traffic control related to schools is a sensitive and controversial subject. The methods used to protect children as they walk to school need to be carefully considered and analyzed by traffic engineering professionals on a case-by-case basis before solutions are implemented.

According to the Institute of Transportation Engineers (ITE) manual, *Design and Safety of Pedestrian Facilities*, the majority of drivers do not typically reduce their speeds in school zones unless they perceive a potential risk, such as the presence of police or crossing

guards, or clearly visible children. Overuse of signs and other devices can cause drivers to be less responsive and attentive. Unnecessary installation of traffic controls lessens the respect for traffic controls that are warranted. Placement of signs, crossing treatments, and traffic control devices need careful consideration.

According to the ITE's *School Trip Safety Program Guidelines*, a number of elements should be studied to determine the appropriate types of crossing treatments and traffic control in school zones or along school walk routes, including, but not limited to:

- existing and potential traffic volumes and speeds,
- inventory of existing traffic control devices and roadway facilities,
- adequacy of gaps in the stream of traffic,
- numbers and ages of children crossing (pedestrian volumes and characteristics),
- adequacy of sight distance,
- collision statistics, and
- location of the school and relationship to surrounding land uses (both existing and planned).

These elements should be considered under the direction of a professional traffic engineer and the results reviewed with the local public works agency, as well as a safety advisory committee established by the school district. There are many variables related to these elements and how they might influence design treatments.

Types of Traffic Control and Crossing Treatments

There are several types of crossing treatments and traffic control devices that may be appropriate in school zones and along school walk routes under varying conditions. Crossing treatments are usually necessary at locations where adequate gaps are not currently available in vehicular flow to allow school children to cross safely. Table 29 lists potential types of traffic control and crossing treatments that may be implemented near schools. Each of these treatments is summarized below. More detailed design information for most of these can be found in other sections of this guidebook. Check with your local agency to determine the accepted practices for your specific project.

Reduced Speed Zones

State law requires the maximum speed limit of 32 kph (20 mph) for school zones (inside or outside incorporated cities or towns). This speed limit is required to extend 91 meters (300 feet) in either direction from the school and from marked crosswalks near the school (RCW 46.61.440). A lower maximum speed limit may be established within a school zone or other area whenever the local jurisdiction determines that on the basis of an engineering and traffic investigation, the maximum speed permitted is more than is reasonable and safe under existing conditions (RCW 46.61.415). Consider reducing the speed limit to lower than 32 kph (20 mph) in school zones where special hazards exist and a traffic engineering study determines that such a speed reduction is warranted.

Traffic Calming

Traffic calming techniques are used to slow vehicles and to reduce non-local through-traffic. Various techniques can be used on

Potential Traffic Control and Crossing Treatments Near Schools

- Reduced speed zones (see discussion below)
- Traffic calming techniques
- Marked crosswalks at intersections and mid-block
- Stop controlled crosswalks
- Signalized crossings (with pedestrian actuators)
- Flashing beacons (check with your local agency)
- Grade separated crossings
- Crossing guard or school patrolled crossings
- Signing and marking

Table 29

different classifications of roadways, but traffic calming is generally most appropriate and effective on local access streets in residential areas.

On street systems surrounding schools and in school zones, traffic calming can be an effective means to create a safer and more comfortable environment for children walking to school. Some examples of traffic calming techniques that may be appropriate include raised crossings, refuge islands at crossings, traffic circles, chicanes, bulb-outs, speed humps, narrower streets, on-street parking, trees and landscaping along the right-of-way, and gateways. Speed enforcement and speed watch programs are also good methods for calming neighborhood traffic in school zones,

although their effectiveness may only last for a limited time, unless consistently implemented. Refer to Toolkit Section 8 for more specific design recommendations related to traffic calming.

Marked Crosswalks

The issue of providing marked versus unmarked crosswalks at intersections is often debated. For a discussion on studies related to the effectiveness of marked and unmarked crosswalks, refer to Toolkit Section 6 — Intersections.

All crossing points within school zones and along school walk routes, typically within 1.6 kilometers (1 mile) of a school site (but may include intersections and crossings outside of this distance), should be evaluated to determine where to mark crosswalks. The *Manual on Uniform Traffic Control Devices (MUTCD)*, requires crosswalks to be marked at all intersections on established routes to schools:

- where there is measurable conflict between vehicles and kindergarten or elementary students (while crossing),
- where students are permitted to cross between intersections, or
- where students could not otherwise recognize the proper place to cross.

Marked crosswalks are often located at signalized and stop controlled intersections or mid-block crossings, or at intersections or locations where traffic volumes meet warrants for pedestrian signals using the MUTCD guidelines. Marked crosswalks may be provided at other locations when a traffic engineering analysis determines the need.

Under Washington Administrative Code (WAC) 392-151-030, school patrolled crossings (with either student patrollers or adult crossing guards) shall not be operated unless



Mid-block school crossing.

proper traffic control devices are in place. At a minimum, these devices shall consist of school crossing warning signs (S1-1 and S2-1), marked crosswalks, and school speed limit signs. Figure 30 illustrates a typical crosswalk layout near a school with advance warning signs, reduced speed zone and marked crosswalk. For design considerations related to the various types of crosswalk markings, refer to Toolkit Section 6 — Intersections.

Stop Controlled Crosswalks

Stop controlled crosswalks, consisting of stop signs and stop bars, with or without actual crosswalk markings, provide the added protection of having all vehicles stop at the crossing. Since vehicles must stop at the stop signs in these locations, there is typically less need for paid adult crossing guards or student patrols. Additional protection with crossing guards and/or student patrols may be necessary at intersections where pedestrian volumes are high and traffic volumes are moderate or higher.

Signalized Crossings (With Pedestrian Actuators)

Most new traffic signals installed in Washington provide marked pedestrian actuation buttons and symbolic “walk/don’t walk” indications. It is appropriate to install

signals at locations other than signalized intersections for pedestrian crossings. Examples include frequently used mid-block crossings and crossings to school sites.

The MUTCD defines warrants for installation of traffic signals at school crossings. The MUTCD recommends that a traffic engineering study be conducted to determine the frequency of gaps in the vehicular traffic stream that allow pedestrians to cross. When crossing gaps are less than one per minute and of insufficient duration to allow the size of group to cross, a signalized crossing may be needed.

Provide pedestrian signal indications and push buttons at signalized school crossings and mark the designated crosswalks. For a complete discussion on signal placement and design, refer to the MUTCD.

The services of a school patrol program (adult crossing guard or student patroller) may not be necessary at all signalized intersections near the school unless special problems exist. School patrol services can provide additional protection at intersections where pedestrian volumes are high and traffic volumes are moderate to high. See the discussion under School Patrolled Crossings for appropriate locations for adult crossing guards versus student safety patrollers.

More information related to intersections, crossings and signalization can be found in Toolkits 6 and 7.

Flashing Beacons

Flashing beacons are common devices used in school zones, and they come in varying styles (mounted to school speed limit signs, and overhead crosswalk signs). The effectiveness of flashing beacons is an often debated issue. The flashing light alerts drivers in advance to

the potential of pedestrians without forcing them to stop. Some studies indicate that after drivers have become accustomed to seeing the beacons in advance of conditions that do not appear to be truly unusual, they stop paying attention the flashing light. This can result in a disregard for all beacons, even those that are truly needed (*Flashing Beacons*, Association of Washington Cities and County Road Administration Board).

Flashing beacons are most effective when used as a warning of truly unusual or hazardous conditions not readily visible to the driver, such as a stop sign located just beyond a curve that is hidden from view of the driver. It is a common practice for flashing beacons to be attached to school speed limit signs. These beacons are only activated during hours that students are present in the school zone. Flashing beacons are discussed under section 4E of the MUTCD relating to hazard identification beacons, and a mid-block crosswalk is one of the specific applications noted for this device. Please refer to the MUTCD for more specific guidance related to the use of flashing beacons (also see discussion under Signing and Marking later in this section).

Grade Separated Crossings

Grade separated crossings may be necessary to physically separate the crossing of a very heavy volume of school pedestrian traffic and a heavy vehicular flow, or where the roadway's cross section is exceptionally wide, such as freeways and principal arterials. Typical types of grade separated crossings include overpasses and underpasses. Because these facilities are costly in comparison to other crossing solutions, they should be considered only in areas where large numbers of pedestrians will benefit. Grade separated crossings need to be easily accessible and convenient to use or they may lose their

effectiveness. Pedestrians may be tempted to try crossing at grade instead of using the overpass or underpass. For additional design guidelines related to grade separated crossings, refer to Toolkit Section 7 — Crossings.

Crossing Guard and Student Patrol Controlled Crosswalks

Some specific design considerations related to school patrolled crosswalks (adult crossing guard or student patrolled) have already been discussed under the various traffic control and crossing treatments in this section. Traffic engineering studies can determine the need for and placement of school patrols at crosswalks on a case by case basis. It is important to coordinate with local jurisdictions on the use of school patrollers.

The use of well trained adult crossing guards is considered to be one of the most effective methods of school zone traffic control. Student safety patrollers, who are most often students at the school, can also provide supervision and direction at crosswalks near schools. Adult crossing guards can be appointed as members of the school patrol under certain conditions (see Table 30).

Sometimes vehicular traffic is such that control by a police officer or adult school patrol member or a traffic signal is required. In this



Adult crossing guard at busy intersection near an elementary school.

When to Utilize Adult Crossing Guards

- Lack of adequate gaps due to high volume of traffic
- When 85 percent of the traffic exceeds the speed limit by 8 kph (5 mph)
- When there is restricted sight distance
- When the location or distance from the school building is such that poor supervision of students would otherwise result
- When there is a high volume of traffic in a crosswalk
- When the location has been determined by either school or law enforcement authorities to be beyond the capacity of a student to make rational decisions concerning safety
- When there is an excessive volume of pedestrian traffic over a highway
- When any of the above criteria exists and there is a lack of an alternative school route plan

Source: WAC 392-151-055 Utilization of adult patrol members

Table 30

case, student school patrol members can assist by directing students to cross in conformance with the direction given by the police officer or adult patrol member, or in conformance with the time cycle of the signal. Student safety patrol members should typically be selected from upper grade levels, preferably not below the fifth grade. Student safety patrollers should not be directed or authorized to halt or direct vehicular traffic. Their purpose is to supervise and assist children, not to control

vehicular traffic. Table 31 describes the primary functions of student safety patrollers.

Primary Functions of Student Safety Patrollers

- Instruct, direct, and control students in crossing streets at or near schools
- Assist teachers and parents in instructing school children in safe pedestrian practices

Source: A Guidebook for Student Pedestrian Safety

Table 31

Signing and Marking

The types of school signs authorized by the MUTCD are shown in Figure 26. The sign placement requirements discussed below are from the MUTCD.

School Advance Sign (S1-1)

The School Advance sign is intended for use in advance of locations where school buildings or grounds are adjacent to the roadway. This sign is also placed in advance of any School Crossing sign (S2-1). The School Advance sign is placed not less than 46 meters (150 feet) in advance and not more than 213 meters (700 feet) in advance of the school grounds or school crossing.

School Crossing Sign (S2-1)

This sign is used at established crossing points, except at crossings controlled by stop signs. Typically only crossings adjacent to schools and on established school pedestrian routes are signed. This sign is erected at the crosswalk or at the minimum distance possible in advance of the crosswalk. These signs can be placed at either signalized or unsignalized crossings, at intersections or mid-block, including official school crossings.

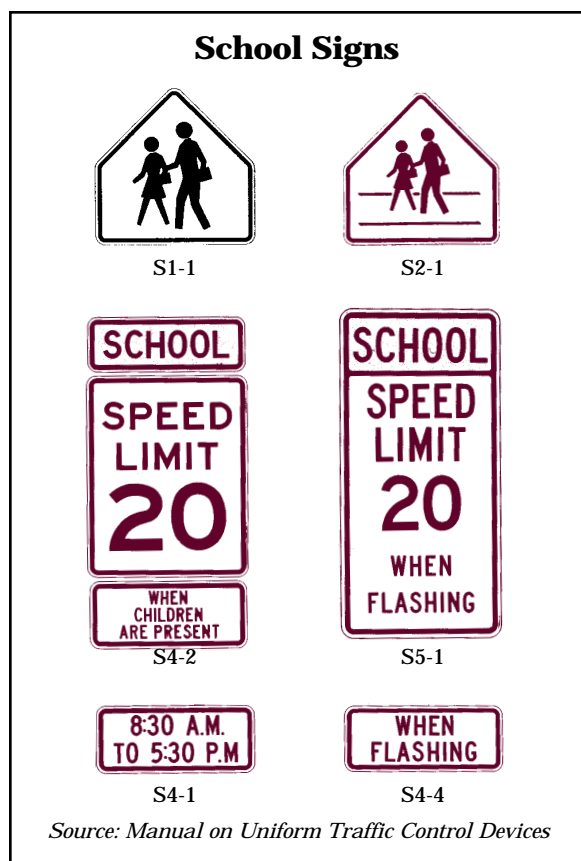

Figure 26

School Bus Stop Ahead (S3-1)

School Bus Stop Ahead signs are intended for use in advance of locations where a school bus stop is not visible for a distance of 150 meters (500 feet) in advance. It is not intended for these signs to be placed everywhere a school bus stops, but only in locations where terrain or other features limit sight distance and there is no opportunity to relocate the stop to a more visible location.

School Speed Limit Signs (S4-1, S4-2, S4-3, S4-4)

School Speed Limit signs are used to indicate the speed limit within the school zone. School Speed Limit Signs may be accompanied by signs that indicate applicable hours or conditions of speed limit reduction (“when children present”). A flashing beacon along

with a sign “When Flashing” may also be used to identify the periods when the school speed limit is in force.

Overhead Crossing Signs

Overhead School Crossing signs are sometimes used at school crossings, but are not contained within the MUTCD and are considered to be extraordinary traffic control devices. These devices are only installed at locations where school authorities request supplemental traffic control for marked school crosswalks and only after a traffic engineering analysis considers other traffic control measures. When such signs are installed, they should include flashing lights that are on only at the time school children use the crosswalk. The school district should be responsible for ensuring that the flashing lights are on at the appropriate times. Flashing lights may be similarly used on School Speed Limit signs if installed in accordance with the MUTCD requirements.

School Sign Test Program

A technique being experimented with in school zones around the state (Auburn, Kirkland, Redmond, and King County) and nationally is the use of different colored school area signs. This is a test program being conducted by the Federal Highway Administration (FHWA) to determine if a new florescent yellow-green color should be used on school zone signs. This color of sign is used only in school zones, and heightens driver awareness by placing an unexpected element (sign color) in their environment. Drivers who see the different colored signs then come to know that the different color represents a school zone, prompting them to look carefully for children as they are driving through.

“School” Markings

The MUTCD allows word and symbol markings on the pavement for the purpose of

guiding, warning, or regulating traffic. They are typically limited to not more than a total of three lines of words or symbols and are white in color. These types of markings are not used for mandatory messages except in support of standard signs. Figure 27 illustrates the school pavement marking design standard.



Figure 27

School Walk Routes and Safety Programs

School walk route plans are required by the Washington Administrative Code (WAC 392-151-025) for all elementary schools in Washington. The *Guidebook for Student Pedestrian Safety* distributed by WSDOT and the Office of the Superintendent of Public Instruction describes a community-based, step-by-step process to develop school walk routes. Procedures for developing school walk routes are listed in Table 32.

Once the school walk route has been established, pedestrian safety deficiencies along the walk route need to be identified, then remedial actions can be considered and implemented as funding becomes available. Refer to *A Guidebook for Student Pedestrian Safety* for guidelines for identifying pedestrian

Procedures for Developing School Walk Routes

1. Form Safety Advisory Committee (SAC)
2. Prepare base maps
3. Inventory existing walking conditions
4. Inventory traffic characteristics
5. Design the walk routes
6. Prepare the draft walk route maps
7. Review the route maps with the SAC
8. Have route maps approved by the school board
9. Distribute and explain the maps
10. Evaluate the program

Source: A Guidebook for Student Pedestrian Safety

Table 32

safety deficiencies and developing remedial actions.

Ongoing Maintenance

The school district and school site officials are responsible to provide ongoing maintenance of pedestrian facilities and traffic control elements on the school site. This includes sidewalks within the right-of-way adjacent to the school site. State law requires public and private property owners to be responsible for repairs and reconstruction of the sidewalk within the street right-of-way adjacent to their property (RCW 35.69.020). Local jurisdictions are responsible for maintaining facilities and traffic control elements at intersections and mid-block crossings. On an annual basis,

before the opening of school each year, elements that affect pedestrian travel in the area of the school should be inspected. Some of the things to look for include:

- Signs that are clearly visible and easy to read (paint has not worn off; tree branches are not in the way)
- Traffic control devices, signals, and actuators that function properly
- Sidewalks and walkways that are clear of obstruction; pavement that is smooth
- Crosswalks and pavement markings that are clearly visible
- Pedestrians visibility that is not compromised by overgrown landscaping, parking, signs, fencing, or other obstacles at intersections, crossings, and along walkways

Other Sources of Information

For more specific design guidelines for various pedestrian facilities that may be developed within the vicinity of schools, refer to the other toolkit sections of this guidebook, including Toolkit 2 — Accessibility, Toolkit 4 — Trails and Pathways, Toolkit 5 — Sidewalks and Walkways, Toolkit 6 — Intersections, Toolkit 7 — Crossings, and Toolkit 8 — Traffic Calming.

The following sources are recommended for design recommendations and other information related to pedestrian facilities for children and school zones. Please see the Resource Guide included at the end of this guidebook for complete bibliography information.

A Guidebook for Student Pedestrian Safety, Final Report, KJS Associates Inc., MacLeod Reckord, and Educational Management Consultants

Childhood Injury Prevention, A Directory of Resources and Program in Washington State, Washington State Department of Health

Design and Safety of Pedestrian Facilities, A Proposed Recommended Practice of the Institute of Transportation Engineers, ITE Technical Council Committee 5A-5

Elementary School Catalog, AAA Foundation for Traffic Safety

Florida Pedestrian Planning and Design Guidelines, University of North Carolina

Guidelines for the Installation of Crosswalk Markings, Steven A. Smith and Richard L. Knoblauch

Handbook for Walkable Communities, Washington State Pedestrian Facilities Planning and Design Courses, Dan Burden and Michael Wallwork, PE

Kids and Cars Don't Mix, Seattle Engineering Department

"Make Their First Steps Safe Ones," Robert B. Overend

Manual on Uniform Traffic Control Devices for Streets and Highways, 1988 Edition, US Department of Transportation

Trails and Pathways

This Toolkit Section Addresses:

- *Trails and Pathways Across Multiple Jurisdictions*
- *Regional Connectivity*
- *Accessibility of Trails and Pathways*
- *Multi-Use Trails and Pathways*
- *Recommended Dimensions*
- *Paving and Surfacing*
- *Grades, Cross Slopes, and Drainage*
- *Shoulders, Side Slopes, and Railings*
- *Connections and Crossings*
- *Managing Motor Vehicle Access*
- *Vegetation and Landscaping*
- *Seasonal and Nighttime Use*
- *Maintenance*
- *Other Sources of Information*



Trails and pathways provide recreational opportunities as well as increased transportation choices.

This section provides design recommendations related to trails, pathways, and paths that are independently aligned and not typically located parallel to streets or within road rights-of-way. These types of trails and pathways are generally found within open spaces of planned residential communities and subdivisions, abandoned railroad rights-of-way, utility easements, parks and greenways, campuses, private developments, and along waterfronts.

Trails and pathways commonly serve a variety of pedestrians, including commuters, schoolchildren, neighborhood residents, and recreational users such as joggers and skaters. Trails and pathways that accommodate two-way traffic and are shared with bicyclists and equestrians are commonly referred to as “multi-use” or “shared use” pathways or trails.

Trails and Pathways Across Multiple Jurisdictions

When a trail or pathway crosses over boundaries of multiple jurisdictions (state, county, and city rights-of-way, parks, and railroads), cooperative coordination between jurisdictions for the planning, design, operation, and maintenance of the facility is essential. Communities can benefit from working together to coordinate improvements and linkages for region-wide nonmotorized systems.

Regional Connectivity

Trails and pathways can enhance pedestrian mobility and regional connectivity. When well planned, designed, and maintained, trails and pathways can provide convenient routes of travel within communities, linking popular origins and destinations such as parks, schools, and community centers. Trails and pathways are not typically an adequate substitute for a full system of on-street nonmotorized improvements. Rather, they serve as important linkages in the overall nonmotorized system.

Accessibility of Trails and Pathways

Trails and pathways provide important outdoor recreational opportunities and transportation alternatives for everyone. It is always the best design practice to provide pedestrian facilities that are accessible, including trails and pathways. At least one accessible route of travel, located entirely within the site boundary, must connect public transportation stops, accessible parking spaces, passenger drop-off and loading areas, and public streets or sidewalks with the accessible entrance to the site and primary developed activities and elements (buildings, shelters, restrooms, and programs). To the maximum extent feasible, the accessible route must coincide with the route for the general public.

If the recreational trail or pathway is not functioning as an accessible route of travel between buildings and facilities and cannot be designed to be fully accessible due to topography or other physical site constraints, it may be exempt from some of the design requirements related to the Americans with Disabilities Act (ADA). Check with your local

agency, WSDOT, and federal agencies such as the US Architectural and Transportation Barriers Compliance Board (Access Board) and FHWA to determine if your project is eligible for certain exemptions from the ADA design provisions.

Even though full compliance with the ADA design provisions may not be required, trails and pathways should be designed to provide accessible recreation experiences for everyone to the maximum extent possible. An accessible spur trail that extends off the main trail to a special point of interest, or sections of trail that serve varying levels of ability are examples of accessible recreation experiences that can be provided when it is not feasible to develop the entire trail or pathway as an accessible route. Figure 28 illustrates an accessible trail/pathway.

For more accessibility design guidelines and information related to the ADA, refer to Toolkit 2 — Accessibility.



Figure 28

Multiple Levels of Accessibility

Trails and pathways in parks and other open spaces are commonly designed to provide experiences for differing levels of accessibility. The levels of accessibility served may depend on the setting. In urban parks and open spaces, a full range of accessible recreation opportunities, including trails and pathways that provide easy access, are typically expected by the general public. In rural and primitive areas, full accessibility is not generally expected, and trails and pathways that serve varying levels of accessibility are commonly provided. Some trails may serve as accessible routes of travel, while others may have steeper gradients and unpaved surfaces. Individuals are then free to choose a trail that provides the recreation experience and degree of challenge that they desire.

Universal Access to Outdoor Recreation: A Design Guide, developed by the PLAE and the USDA Forest Service, provides extensive design guidance related to outdoor recreation trails and pathways. It includes a recreation trail rating system and suggests that trails be signed to indicate the level of accessibility: easy, moderate, and difficult (see Figure 29).

The design guide contains design guidelines for trails classified as easy, moderate and difficult. There are several other sources of information available for trail and pathway design. The City of Bellevue’s *Development Manual* provides illustrative design details for various types of trails. See the list at the end of this toolkit section for other good sources. Trail design guidelines summarized from *Universal Access to Outdoor Recreation: A Design Guide* and other sources are summarized in Table 33.

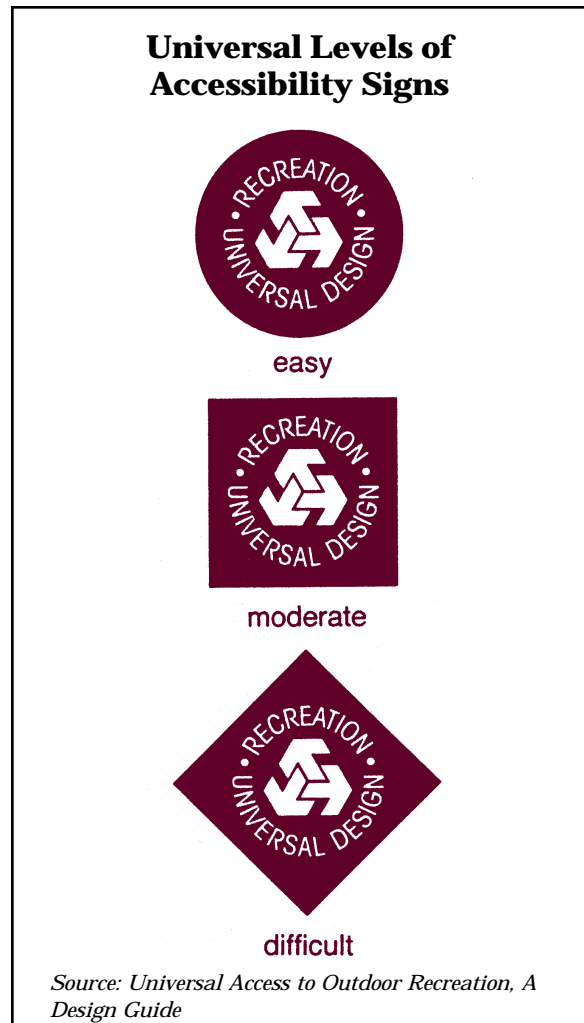

Figure 29



Trails and pathways serve a wide variety of users.

Design Element	Levels of Accessibility		
	Easy	Moderate	Difficult
Surfacing	Paved — Asphalt/ Concrete Boardwalk with ramped or level entry	Compacted crushed rock or compacted dry earth	Varies, but needs to be firm and stable
Clear width	1.2 m (48 in)	.9 m (36 in)	.7 m (28 in)
Sustained running slope	5 percent	8.3 percent	12.5 percent
Maximum grade For a Maximum Distance of	8.3 percent* 9.1 m (30 ft)	10 - 14 percent 15.2 m (50 ft)	20 percent 15.2 m (50 ft)
Cross slope maximum	2 percent	3 percent	5 percent
Passing space interval	61 m (200 ft) maximum	91 m (300 ft) maximum	122 m (400 ft) maximum
Rest area interval	122 m (400 ft) maximum	274 m (900 ft) maximum	366 m (1,200 ft) maximum
Small level changes	1.3 cm (0.5 in) maximum	2.6 cm (1 in) maximum	7.6 cm (3 in) maximum

** If the pathway is designated as an accessible route of travel on the site, handrails are required on both sides of the pathway wherever the grade exceeds 5 percent.*

Source: Adapted from Universal Access to Outdoor Recreation, A Design Guide

Table 33

Multi-Use Trails and Pathways

Trails and pathways may be developed for the exclusive use by pedestrians, or they may be shared with bicyclists and equestrians of varying skill levels. Design of multi-use pathways needs to carefully consider the

various skill levels, experience, and characteristics of these different users.

Minimizing Conflicts Between Trail Users

The mix of pedestrians and bicycles on a multi-use trail is not always a desirable situation because the potential for conflicts is

high. Trails heavily used by commuting bicyclists present problems for families on recreational strolls. Children are particularly at risk on multi-use trails because they tend to travel at slower speeds than average bicyclists and their movements are unpredictable. They may change direction unexpectedly in front of an approaching bicyclist. Conflicts between bicyclists and pedestrians can be avoided by designing the trail to separate them.

When trails and pathways must be shared by pedestrians and bicyclists, they need to be designed in accordance with applicable standards (refer to WSDOT and AASHTO design requirements). Adequate visibility and sight distance is crucial. Design treatments that help to improve multi-use trails and pathways so that they are safer for use by everyone include:

- Horizontal and vertical alignment to ensure clear lines of sight for pedestrians and bicyclists
- Wide shoulders, 0.6 meters (2 feet) minimum on each side, to provide stopping and resting areas and allow for passing, and widening at curves
- Avoidance of view obstructions at edges of the trail by placing signs, poles, utility boxes, garbage cans, benches, and other elements away from the edge of the path and using low-growing landscaping or high-branching trees
- Use of bicycle speed limits
- Use of delineation and separation treatments (see Table 34)
- Use of directional signing

- Signing and marking (refer to the *Manual on Uniform Traffic Control Devices*); a 10-centimeter (4-inch) wide centerline stripe may be considered for multi-use pathways with heavy volumes of pedestrians and bicyclists, on curves with restricted sight distance, and on pathways where nighttime use is expected (see Table 34); edge lines can also be beneficial on pathways experiencing nighttime use

If a multi-use pathway must accommodate a higher number of users, it needs to be as wide as possible with a paved width of 3.7 meters (12 feet) desirable or 3 meters (10 feet)

**Delineation/Separation
Treatments for Multi-Use
Pathways**

- Colored paving
- Signing
- Textured paving or paving patterns*
- Pavement markings — symbols or words (slip resistant finish)
- Striping with education program about trail use and other measures**
- Combinations of two or more of the above

* *Raised pavement markers are not an acceptable method of delineation for pathways shared with bicyclists, but some textured surfaces are acceptable; check with your local agency.*

** *Striping is most helpful on curves and other areas where sight distances are decreased, but when used, it should include a public education program to help trail users understand what the striping means and remind them of trail use etiquette (see Figure 30).*

Table 34

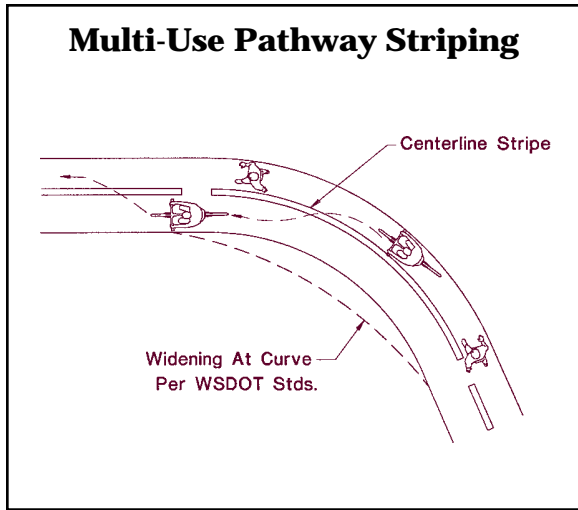

Figure 30

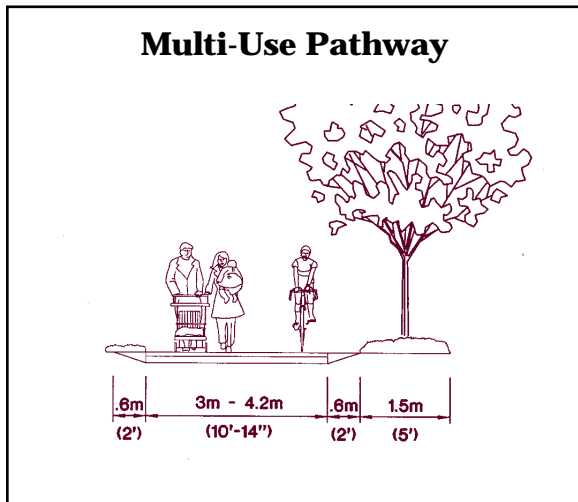

Figure 31

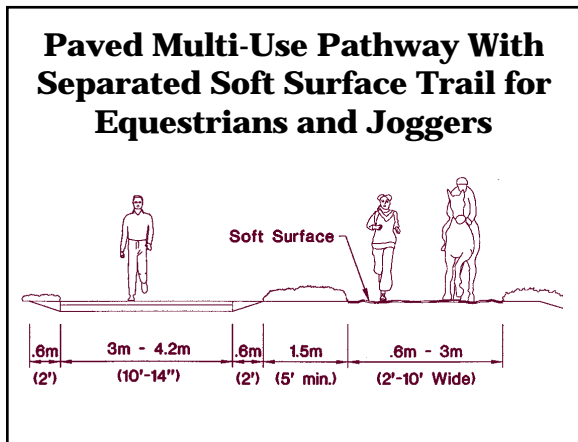

Figure 32

minimum, and with 0.6-meter (2-foot) wide shoulders on both sides (see Table 36, Recommended Dimensions). Figure 35 illustrates a typical multi-use pathway shared by pedestrians and bicyclists.

A separate, soft-surface jogging or equestrian path may be constructed using wood chips, gravel, or other suitable material, parallel to but separated from the paved path (see Figure 32).

Some special delineation treatments that can be implemented to help minimize conflicts between pedestrians and other trail users are listed in Table 34.

Multi-Use Trails and Pathways Next to Roadways

Multi-use two-way trails and pathways aligned along a street do not typically function well due to problems related to bicycle use. For example, on a multi-use two-way pathway, some of the bicyclists will be travelling against the normal flow of motor vehicle traffic, which is contrary to the rules of the road.

Conflicts at intersections and driveways are a major concern on pathways adjacent to roadways. Motorists will often not notice bicyclists coming toward them on the right, since they do not expect to see them travelling against the flow of traffic. Additional problems are listed in the AASHTO *Guide for the Development of Bicycle Facilities*.

The feasibility of developing a multi-use pedestrian and bicycle pathway within the right-of-way and adjacent to a roadway should be carefully considered. The following conditions should exist before determining that a multi-use pathway within the right-of-way is necessary:

- The pathway can be separated from motor vehicle traffic. Minimum horizontal separation of 1.5 meters (5 feet) is required by AASHTO standards, as illustrated in Figure 33.
- Development of bike lanes and sidewalks as an alternative to the multi-use pathway would not be a feasible alternative. (Bike lanes and sidewalks typically take up less space than multi-use pathways within the right-of-way and allow bicyclists to travel with the normal flow of traffic.)
- There are no reasonable alternative alignments for bikeways and sidewalks on nearby parallel routes.
- There is a commitment to provide a continuous nonmotorized system throughout the corridor.
- Bicycle and pedestrian use is anticipated to be high.
- The pathway can be terminated onto streets with good bicycle and pedestrian facilities, or onto another safe, well designed pathway at each end.
- Potential driveway and intersection conflicts can be minimized or mitigated.
- There are popular origins and destinations throughout the corridor (schools, parks, and neighborhoods).
- The pathway can be constructed wide enough to accommodate all types of users, with delineation and separation techniques to minimize conflicts between users — 3.7 meters (12 feet) desirable, 4.3 meters (14 feet) optimum.

When there is no feasible alternative to locating a two-way multi-use pathway within the roadway right-of-way, adequate separation is required. The wider the separation dimension, the better. A minimum separation of 1.5 meters (5 feet) is required by AASHTO. Recommendations for separation treatments are provided in Table 35.

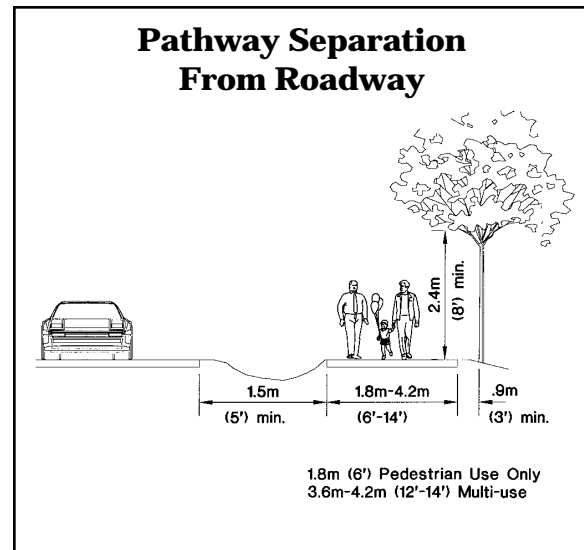

Figure 33

Separation Treatments for Multi-Use Pathway Next to Roadway

- 1.5-meter (5 ft) minimum width
- Landscaped or natural vegetation to provide buffer from noise and splash of vehicles and/or
- Drainage ditch or swale with maximum 1:3 side slopes at edge of 0.6-meter (2-ft) wide shoulder
- If less than 1.5 meters (5 feet), a concrete barrier divider, wall and/or railing a minimum of 1.4 meters (4.5 feet) high is required by AASHTO.

Table 35

Recommended Dimensions

Design dimensions for trails and pathways can vary depending on the type of facility, levels of use they receive, and the setting in which they are located. Table 36 lists recommended dimensions for various types of pathways and trails.

Geometric standards (horizontal curvature, and sight distance) related to design of multi-use pathways can be referred to in the WSDOT *Design Manual*, Section 1020, Nonmotorized Transportation and in AASHTO's *Guide for the Development of Bicycle Facilities*.

For multi-use trails and pathways that receive high levels of use, the optimum dimension in Table 36 is recommended. Dimensions for other types of pedestrian pathways (other than paved multi-use trails) are also provided in the table. Pedestrian-only paved paths are typically found in parks or in neighborhood open spaces (see Figure 34). Unpaved

pedestrian-only and multi-use paths are also found in parks and open spaces, as well as in undeveloped and natural areas. Unpaved trails and pathways are best used for areas with low use and limited purposes or as interim solutions until they can be fully improved.

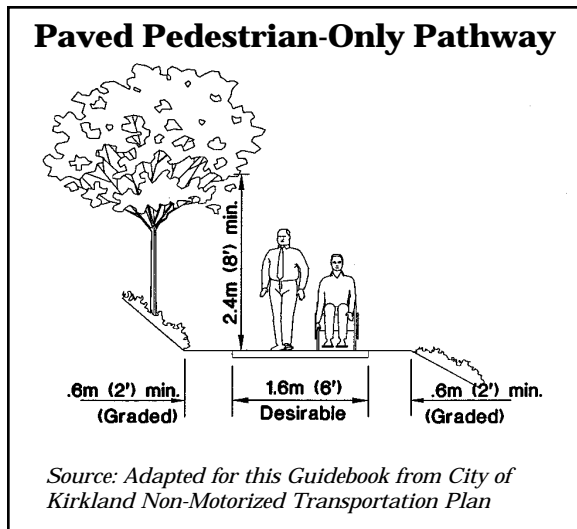

Figure 34

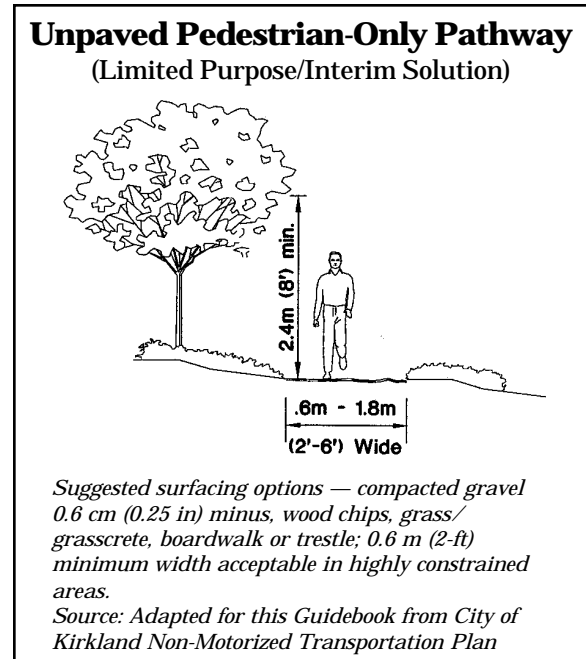

Figure 35

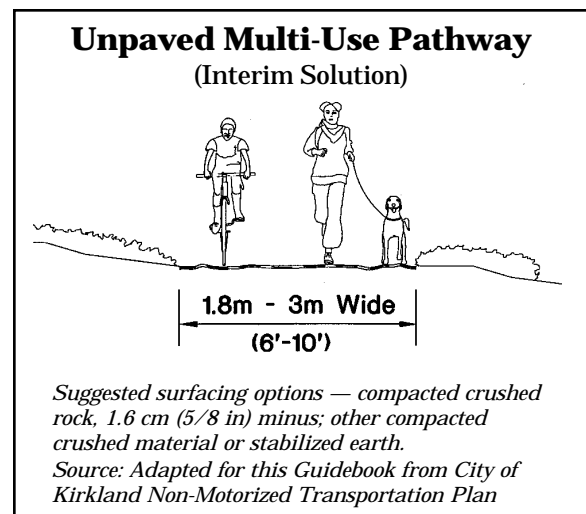

Figure 36

Recommended Dimensions for Trails and Pathways

Trail/Pathway Element	Recommended Dimensions			Comments
Multi-Use Pathway Width (two-way, shared with bicyclists)	3.0 m	(10 ft)	minimum	Minimum width should only be used where volumes are low and sight distances are good; width should be based on relative speed of users; higher speed users (bicyclists and skaters) require greater widths.
	3.7 m	(12 ft)	desirable	
	4.3 m	(14 ft)	optimum	
Roadway Separation	1.5 m	(5 ft)	minimum	Minimum separation for parallel, adjacent path; a physical barrier should be installed where minimum separation cannot be met.
Shoulders	.3 m	(1 ft)	minimum (peds only)	Shoulders provide pull-off/resting and passing space; should be graded to the same slope as the path; minimum shoulder width of 0.3 m (1 ft) should only be used in constrained areas.
	.6 m	(2 ft)	minimum (multi-use)	
Additional Lateral Clearance Each Side of Shoulder	.3 m	(1 ft)	minimum*	Lateral clearance is necessary for safe operation on either side of a multi-use path; should be graded to the same slope as the path.
	.6 m	(2 ft)	desirable*	
Vertical Clearance	2.4 m	(8 ft)	minimum	Necessary for good visibility and clearance for bikes/horses on multi-use pathways.
	3.0 m	(10 ft)	desirable	
Paved Pedestrian-Only Path Width	1.5 m	(5 ft)	minimum	These pathways are for exclusive use by pedestrians (see Figure 34).
	1.8 m	(6 ft)	desirable	
Unpaved Pedestrian-Only Path Width	.6 m	(2 ft)	minimum	Best as limited purpose facility in rural or semi-primitive areas; can provide interim solution (see Figure 35); minimum width should only be used in constrained areas.
	1.2 -	(4 -		
	1.8 m	6 ft)	desirable	
Multi-Use Unpaved Path Width	1.8 m	(6 ft)	minimum	Only suggested as an interim solution and not appropriate for high use trails; best in rural or semi-primitive areas (see Figure 36).
	2.4 -	(8 -		
	3.0 m	10 ft)	desirable	
Pedestrian Mall/Corridor (Urban) Width	3.0 m	(10 ft)	minimum	Pathways in urban areas or those that receive heavy use should be wide enough to accommodate several people walking side-by-side or groups of people walking in opposite directions.
	3.7 m	(12 ft)	desirable	
	4.6 m	(15 ft)	optimum	

** If less than 1.2 m (4 ft) total lateral clearance is provided (including shoulder) between the edge of trail, and there is a vertical grade drop greater than 0.8 m (30 in), steeper than 2:1, railing may be required. See discussion later in this toolkit section.*

Note: Refer to WSDOT, AASHTO, and your local agency for other guidelines and standards for multi-use pathway dimensions.

Source: This table was compiled based on research of various documents (see Resource Guide) and input from the Pedestrian Facilities Guidebook Advisory Group

Table 36

Paving and Surfacing

When selecting paving and surfacing materials, long-term durability, safety, accessibility, cost, and maintenance are usually the most important criteria.

In general, surfacing materials for trails and pathways in urban areas should be paved or consist of other hard-surfaced materials. Recreational trails and pathways in rural semi-primitive settings can be constructed of materials that blend with the natural setting. Trails in primitive settings will most likely be native soil.

Multi-use pathways shared by pedestrians and bicyclists function best when constructed of a smooth, paved, all-weather surface such as asphalt or concrete, regardless of the setting.

All trail and pathway materials need to provide a firm, stable, and slip-resistant surface throughout the primary seasons of use. A good subbase, such as compacted aggregate material or fully compacted native soil (if structurally suitable), is also important for structural support of multi-use pathways.

Recommended pavement cross sections are illustrated in Figure 37. Check with local standards to determine specific pavement design requirements for your project. Pavement conditions should be checked periodically for potholes or cracks, with repairs when necessary to maintain a smooth surface.

Multi-Use Pathway Pavement Cross Sections

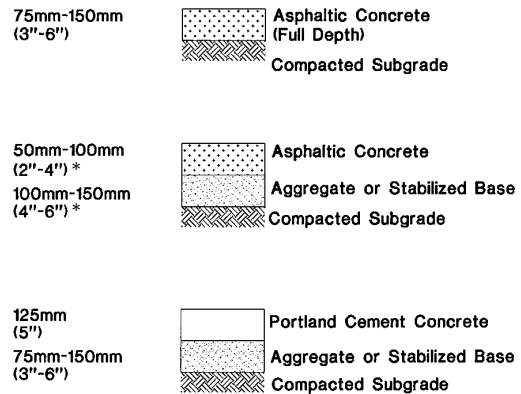

* 100-mm (4-in) A/C and 150-mm (6-in) base are recommended for pathways that need to support motor vehicle access (maintenance and emergency vehicles)

Source: *Time-Saver Standards for Landscape Architecture, Design and Construction Data*

Figure 37



Paved pedestrian-only paths can provide access through parks and neighborhoods.

Grades, Cross Slopes, and Drainage

Trails and pathways can be designed and constructed with various grades, depending on the level of accessibility being served, as discussed previously in this toolkit section. Longitudinal grades on pathways should be kept to a minimum, especially on long inclines. Grades greater than 5 percent are typically undesirable. Where steep terrain exists, grades of 5 to 10 percent can be tolerated for short segments less than 500 feet. The design speed should also be increased and additional pathway width of 0.9 meters (3 feet) should be provided for maneuverability on grades exceeding 5 percent.

It's important to keep pathways free of puddles and water accumulations that could become slippery in cold temperatures. Drainage systems must be designed in accordance with all applicable standards and regulations. Check with your local agency to determine drainage design requirements.

A 1:50 (2 percent) cross slope will facilitate adequate drainage on pathways. Sloping in one direction instead of crowning the pathway is preferred and usually simplifies the drainage and surface construction. Ditches or swales should be provided where necessary to control runoff and provide water quality. Ditches function best on the uphill side of the pathway to intercept drainage.

Drainage grates and inlets are best located at the outside edge of the pathway or off the path entirely. Grid style grates are recommended over grates with parallel bars spaced at 1.3 centimeters (0.5 inches) maximum. Grates should be set flush, less than 1.3 centimeters

(0.5 inches) below the surface of the surrounding pavement, with no raised edges.

Drainage systems should be maintained in good working order year-round, particularly in areas of heavy rainfall.

Shoulders, Side Slopes, and Railings

Recommended widths for shoulders at the sides of trails and pathways are provided in Table 36. In areas where there are side slopes or ditches, a minimum of 1.2 meters (4 feet) of clear, level area (including shoulder) is needed before the up slope or down slope (or ditch) begins. Ditches function best on the uphill side of the pathway to intercept drainage.

Maximum side slopes of 3:1 are recommended. When the grade drops severely from the shoulder of a pedestrian or bike travel way, railings are required by most jurisdictions. When a vertical drop is more than 0.8 meters (30 inches), exceeds a down slope grade of 2:1, and is located less than 1.2 meters (4 feet) from the edge of the trail, pathway, walkway, or sidewalk, railing needs to be installed along the extent of the grade drop. Figure 38 illustrates conditions where railing is required.

Railings are required by AASHTO and WSDOT to be a minimum of 1.4 meters (4.5 feet) in height adjacent to multi-use trails and pathways shared with bicycles. On paths, walkways, and sidewalks used exclusively by pedestrians, the railing can be a minimum of 1.1 meters (3.5 feet) high. Railings are required to be designed with vertical posts, bars, and top and bottom rails spaced so that a 10.2-centimeter (4-inch) sphere cannot be passed through the bars (*Uniform Building*

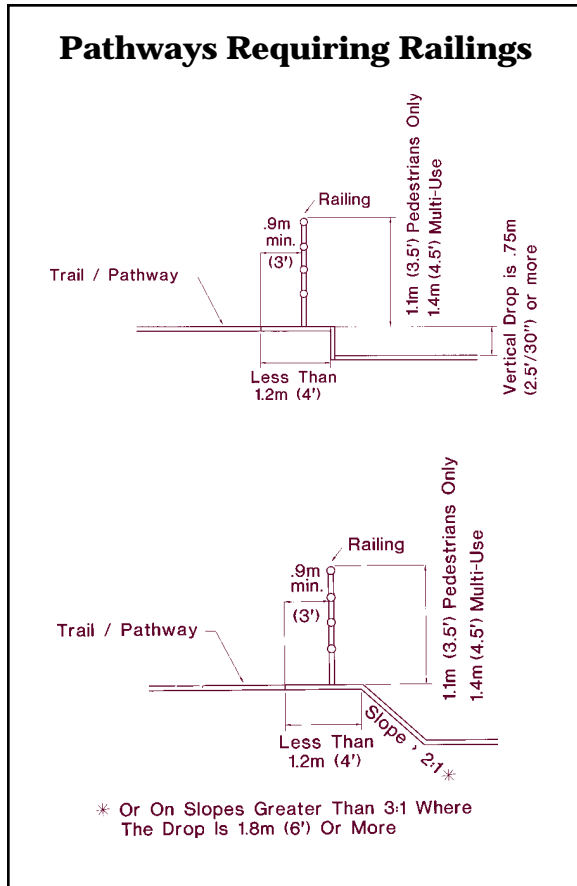

Figure 38

Code, Section 509.3; requirements of local jurisdiction may vary).

A maximum 3:1 slope is also recommended for steep side slopes on the uphill side of pathways. Its best to avoid high retaining walls immediately adjacent to pathways since they may be out of scale with creating a pedestrian friendly environment. High walls should be terraced back from the edge of the pathway shoulder. Blank walls should be screened with landscaping or designed with an attractive face or artwork.

Connections and Crossings

Initial planning of trail and pathway routes should minimize crossing points with roads and driveways as much as possible. Pathways should connect to street systems and destination sites in a safe and convenient manner. Connections should be clearly identified with destination and directional signing. Crossings should be well-designed (see Toolkit 7 — Crossings).

Managing Motor Vehicle Access

As a general rule, separated pathways function best when motor vehicle access is prohibited or limited to maintenance vehicles for periodic inspection, sweeping, and repairs, utility vehicles, and emergency vehicles. The following design treatments are suggested for managing motor vehicle access on pathways:

- Pavement cross-sections with sufficient base and thickness are necessary to support maintenance vehicles while minimizing deterioration. A 10-centimeter (4-inch) asphalt thickness over a 15-centimeter (6-inch) aggregate base is recommended.
- Pathway edges need to be designed with added thickness to support vehicle loads. See Figure 39 for thickened-edge pavement design.
- Access points can be provided from roadways for use by maintenance and emergency vehicles, but blocked from use by other motor vehicles with removable bollards or special gates (see Bollard Design and Placement).

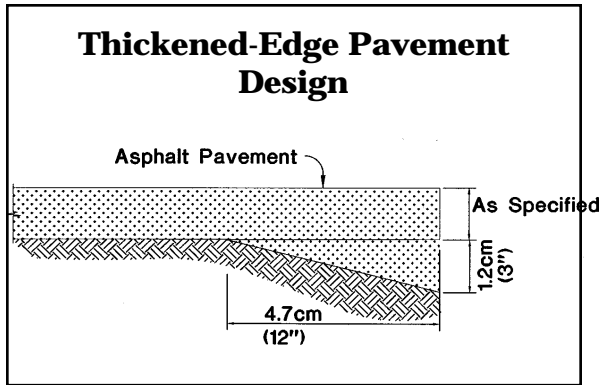

Figure 39

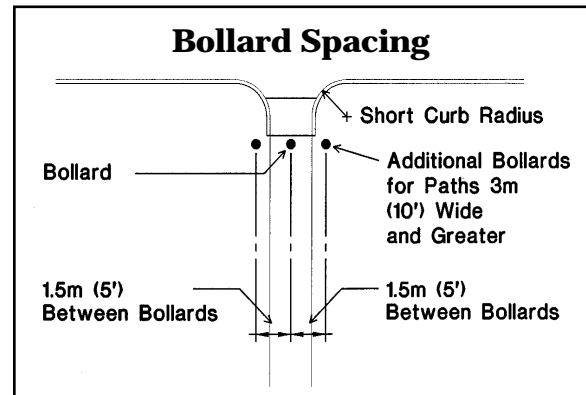

Figure 40

- Gates or fencing at side entrances to the pathway, can be specially designed to allow passage for pedestrians, wheelchairs, and bicyclists without providing an access point for motor vehicles.
- Signing can be installed to notify pathway users that maintenance vehicles may be entering the system at the identified locations; temporary signs and markers need to be carried and placed at appropriate locations as warning devices during maintenance activities.

Bollard Design and Placement

When bollards are placed at pathway entrances, marking them with bright colored reflective paint or emblems increases their visibility to pedestrians and bicyclists. The



Bollards provide access control at points where pathways join or cross roads.

recommended minimum height for bollards is 0.8 meters (30 inches).

Bollards need to be adequately spaced to allow easy passage by bicyclists, bicycle trailers, and wheelchair users with one bollard in the center of the pathway dividing the two-way traffic flow. If more than the center bollard is needed, other bollards should be placed outside the paved area at pathway edges. Figure 40 illustrates suggested bollard placement for various pathway widths.

Entrance Design to Restrict Motor Vehicles

Motor vehicles can be restricted from entering pathways through the use of special design techniques, such as short curb radii or a split path configuration (see Figure 41). These techniques are most appropriate at locations where maintenance and emergency vehicles do not require access to the pathway.

Vegetation and Landscaping

Landscaping and trees placed along pathways need to be carefully selected to avoid the need for excessive pruning, cleanup of fallen fruit and debris, and watering, unless a fully

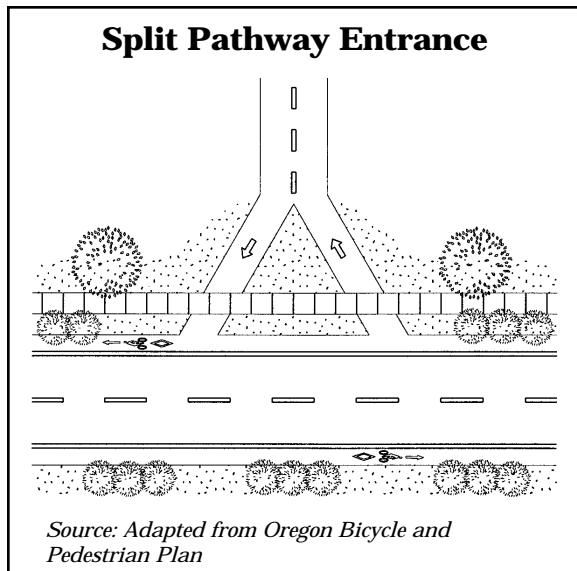

Figure 41

automatic underground irrigation system can be installed. (Where irrigation cannot be installed, drought-tolerant and native species can be planted. Most landscaping, even drought-tolerant, needs some watering during the dry season of the first one or two years to become established.)

Some trees and shrubs (such as cottonwoods or other shallow-rooted species) have a tendency to raise and buckle surrounding pavement areas. These types of trees and shrubs should be avoided near pathways, or root barriers between trees and adjacent pathways should be installed (see Figure 42). Soil sterilants can also be applied to prevent vegetation from erupting through the pavement.

Seasonal and Nighttime Use

Pathways used regularly by pedestrians walking to and from origins and destinations within their communities year-round should be well maintained, with snow removal in

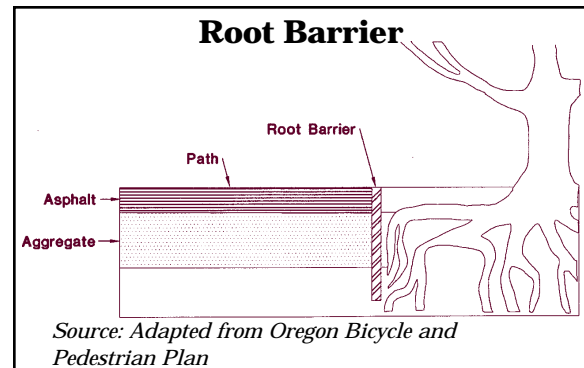

Figure 42

areas of heavy snowfall, cleanup of fallen leaves and debris, and consistently functioning drainage facilities in areas of frequent rainfall.

When pathways are frequently used during nighttime hours, or during the late fall and winter when darkness occurs in late afternoon and early evening, lighting is an important consideration. Lighting should be designed according to applicable local standards, with consideration toward maximizing pedestrian safety and security while minimizing glare and obtrusiveness to surrounding neighborhoods.

Maintenance

Several suggestions have been provided throughout this section related to maintenance. It is important to establish a maintenance program at the time a project is developed to ensure that the pathway will function properly over the long term. Maintenance activities should be scheduled during times of typically low pathway use, if possible. Proper work zone signing is required by State Labor and Industry laws whenever maintenance occurs on or adjacent to pedestrian travel ways.

Other Sources of Information

The following sources of information are recommended for design of trails and pathways. Please see the Resource Guide included at the end of this guidebook for complete bibliography information.

Design Manual, 1020 Facilities for Nonmotorized Transportation, Washington State Department of Transportation

Development Manual, Transportation Department, Parks & Community Services Department, City of Bellevue

Guide for the Development of Bicycle Facilities, American Association of State Highway and Transportation Officials

Handbook of Landscape Architectural Construction, Volume Two, Site Works, Maurice Nelischer

Issaquah Urban Trails Plan

King County Regional Trails Plan

Oregon Bicycle and Pedestrian Plan, An Element of the Oregon Transportation Plan, Oregon Department of Transportation Bicycle and Pedestrian Program

Recommendations for Accessibility Guidelines: Recreational Facilities and Outdoor Developed Areas, Recreation Access Advisory Committee

Standard Plans for Road, Bridge and Municipal Construction, Washington State Department of Transportation

Time-Saver Standards for Landscape Architecture, Design and Construction Data, Charles W. Harris, Nicholas T. Dines

Universal Access to Outdoor Recreation: A Design Guide, PLAI, Inc.



Trails and Pathways

Sidewalks and Walkways

This Toolkit Section Addresses:

- *Determining When and Where Sidewalks and Walkways are Needed*
- *Sidewalks and Walkways in Various Settings*
- *Descriptions and Comparisons of Sidewalks and Walkways*
- *Location — Both Sides Versus One Side*
- *Accessibility*
- *Recommended Dimensions*
- *Passing, Waiting, and Resting Areas*
- *Grades, Cross Slope, and Drainage*
- *Side Slopes, Railings, and Walls*
- *Surfacing*
- *Street Separation and Edge Treatments*
- *Street Furnishings, Utilities, and Related Clearances*
- *Landscaping and Street Trees*
- *Lighting*
- *Signing*
- *Sidewalks in Business Districts and Downtowns*
- *Shoulders as Walkways in Rural Areas*
- *Bicycles on Sidewalks*
- *Street Design Considerations*
- *Maintenance*
- *Other Sources of Information*



Urban center with wide sidewalks.

Pedestrian facilities addressed in this toolkit section include those located within street rights-of-way that are adjacent to or parallel with the roadway, such as sidewalks, walkways, and roadside shoulders used for pedestrian travel.

Sidewalks and walkways function as integral components of pedestrian friendly street systems where pedestrians can experience safety, comfort, accessibility, and efficient mobility. Sidewalks and walkways increase pedestrian safety by separating pedestrians from vehicle traffic. Wide shoulders can be provided where it is not feasible to build a full sidewalk improvement. Table 37 lists priorities for pedestrians traveling along streets.

Priorities for Pedestrians Traveling Along Streets

- Safety
- Efficient mobility
- Defined space
- Visibility
- Accessibility
- Comfortable/attractive environment

Table 37

Determining When and Where Sidewalks and Walkways are Needed

Research has documented that pedestrian travel increases in areas where more pedestrian facilities are available. A recent study completed by the University of Washington confirmed that higher numbers of pedestrians can be found in areas where more complete and continuous sidewalks, walkways, crossings, and other pedestrian facilities exist (see About Pedestrians).

State and federal mandates to increase pedestrian travel, along with research findings that indicate pedestrian travel does increase when more pedestrian facilities are available, provide an important confirmation:

*There **is** a need to increase the general level of pedestrian facilities in our communities, including the available network of sidewalks and walkways. Even if there does not appear to be a current demand for pedestrian facilities, pedestrian travel can almost always be expected to increase when facilities are provided.*



Some type of pedestrian travel way is recommended along all streets and roadways.

In recognition of this need, this guidebook strongly recommends that at least some type of pedestrian travel way be provided along all streets and roadways.

It is recognized that development of pedestrian facilities on all street systems will take time (particularly when retrofitting them into existing transportation systems). Realistically, cities, towns, and counties will gradually look for ways to add pedestrian facilities on a project-by-project basis, as funding and opportunities become available. To reach the overall goal of a more complete pedestrian travel network, local agencies often require pedestrian facilities be constructed as part of private development projects as they occur. The community can then fill in missing links in the network through public funding and capital investment projects.

Table 38 lists criteria that can be analyzed to identify pedestrian safety deficiencies, as recommended by the Institute of Transportation Engineers (ITE).

Determining when and where sidewalks and walkways are needed is typically left up to the local jurisdiction. *A Policy on Geometric Design of Highways and Streets* (Green Book), by the American Association of State Highway and Transportation Officials (AASHTO) provides the following guidance:

- Develop sidewalks as integral parts of all city streets.
- If pedestrian activity is anticipated, construct sidewalks as part of street development.
- Give consideration to connecting the nearby urban communities with sidewalks, even though pedestrian traffic may be light.

ITE Criteria to Be Analyzed to Determine Pedestrian Safety Deficiencies

- Roadway and traffic control device inventory
- Sight distance studies
- The adequacy of gaps in the stream of traffic for pedestrian crossings
- Collision summaries and diagrams
- Conflict analysis
- Pedestrian volumes and characteristics
- Traffic volumes and speeds

Source: Design and Safety of Pedestrian Facilities, A Proposed Recommended Practice of the Institute of Transportation Engineers, ITE Technical

Table 38

- Sidewalks in rural and suburban areas are needed at schools, local businesses, and industrial plants that result in pedestrian concentrations. *(Other appropriate locations might be at parks, office buildings, and of course, in all residential areas.)*
- Traffic volume-pedestrian warrants for sidewalks along highways have not been established. In general, whenever the roadside and land development conditions are such that pedestrians regularly move along a main or high-speed highway, they should be furnished with a sidewalk or path area, as suitable to the conditions.
- The higher speeds of traffic and general absence of lighting in rural areas reinforce the need for sidewalks. Available data suggests that sidewalks in rural areas reduce pedestrian/motor vehicle collisions.

- As a general practice, sidewalks should be constructed along any street or highway not provided with shoulders, even though pedestrian traffic may be light. Sidewalks built along rural highways should be well removed from the traveled way, separated by a ditch or as much space as available within the right of way. (Paraphrased from Chapter IV of the Green Book, discussion on sidewalks.)

The AASHTO Green Book also contains pedestrian level of service criteria for measuring the capacity of existing pedestrian facilities to determine the need for improvements or expansions. If adequate capacity is not provided, pedestrian mobility may be seriously impeded. Refer to Chapter II of the Green Book for a description of this criteria, as well as other guidance for design of pedestrian facilities.

Sidewalks and Walkways in Various Settings

The design of sidewalks and walkways varies depending on the setting and the standards and requirements for those settings imposed by local agencies. Local agency criteria for sidewalks and walkways are typically included in street and roadway design standards.

Most local agencies in Washington have adopted varying design standards for urban and rural areas, as well as more specific requirements that are applicable to residential settings, downtowns, special districts, and other areas. (Check with your local agency to confirm the design requirements that may be applicable to your pedestrian project.)

The design guidelines throughout this guidebook, including the recommendations in this toolkit, address solutions that are appropriate in various locations and settings (such as urban centers, neighborhoods, or rural areas). This information is provided to assist designers in determining the best type of sidewalk or walkway for the setting, which in some cases may require variance from local agency standards currently in place.

An example of how the information in this guidebook might be helpful in justifying a variance from design standards:

The current adopted local agency design standard requires only a 1.5-meter (5-foot) wide shoulder along a rural roadway. Because there are schools, parks, and other pedestrian origins and destinations along this roadway route, traffic engineering staff or others (community groups, or private developers of a nearby subdivision) feel there is a need to develop a 1.8-meter (6-foot) wide sidewalk improvement along both sides of the roadway in this area. The information in this guidebook helps to explain why a full sidewalk improvement in this area is needed, and provides design guidance.

Descriptions and Comparisons of Sidewalks and Walkways

Sidewalks Defined

Sidewalks are typically constructed of concrete and are raised and located adjacent to curbs or separated from the curb by a linear planting strip. Sidewalk widths can vary, but typically they are a minimum of 1.5 meters (5 feet) wide

(clear width) on local residential streets, and can be 1.8 to 4.6 meters (6 to 15 feet), or sometimes wider, on collector and arterial streets, or in special districts.

Walkways Defined

In contrast to sidewalks, which are typically raised, walkways are usually built over the existing ground surface without being raised. Instead of vertical separation by curb and gutter, walkways are usually separated horizontally by a planting buffer or ditch. In some cases, extruded curbs or barriers are used to separate a walkway from adjacent street traffic (see Street Separation and Edge Treatments). Walkways are often constructed of materials other than concrete, such as



Walkway separated from roadway.



An informal path naturally created along a roadway may suggest the need for more formal pedestrian improvements.

asphalt or compacted granular stone or crushed rock. Some local agencies consider asphalt walkways as interim facilities in urban areas until full Portland cement concrete sidewalk improvements can be built. Check with your local agency.

Walkway width can vary, but the minimum recommended width in this guidebook is 1.5 meters (5 feet). When horizontally separated, the minimum separation distance recommended between the edge of the street and a walkway is 1.5 meters (5 feet). The walkway appearance and alignment may be less formal in areas of low use or rural character with compacted crushed rock surfacing or other type of surface. Sometimes, natural paths are created as a result of frequent travel at the side of the roadway. These paths may suggest the need for more formal pedestrian improvements.

Roadside shoulders can serve as suitable walkways in rural areas if designed properly, especially if the alternative is no pedestrian travel area at all. Refer to the discussion later in this section for shoulder walkway design recommendations.

Location — Both Sides Versus One Side

In most cases, it is desirable to provide sidewalks on both sides of streets used by pedestrians. Washington State statute requires pedestrians to walk on sidewalks when they are provided in the right-of-way (RCW 46.61.250). Pedestrians are also encouraged to walk on the side of the roadway facing traffic. Providing sidewalks on both sides enables pedestrians to travel facing traffic in either direction, and minimizes the need for pedestrian crossing points.



Raised sidewalk in small town center.

A sidewalk on one side may be adequate for some local streets, especially when this improves a condition where there were no sidewalks previously.

Several factors influence the decision of whether to place sidewalks, walkways, and widened shoulders on both sides or one side (and which side). These factors include the available space within the right-of-way, the existing physical limitations at the roadside, and which side of the street origins and destinations (such as schools and bus stops) are located.

Accessibility

When sidewalks or walkways are serving as an accessible route of travel between public buildings or facilities, they are required to be designed in accordance with the provisions of the Americans with Disabilities Act (ADA). As a general rule, all sidewalks and walkways should be accessible and should comply with the ADA to the maximum extent feasible. Specific design recommendations for accessibility of sidewalks and walkways are provided throughout this toolkit section. Also refer to Toolkit Section 2 — Accessibility for more information about the ADA

requirements and their relationship to design of pedestrian facilities.

A January 1997 draft of *Accessible Sidewalks: A Design Manual* by the Access Board recognized that compliance with all of the design criteria required of an accessible route on a site is not always feasible on public

rights-of-way. For example, sidewalks are typically constructed to match the grade of the adjacent street, which often exceeds that allowed by the ADA. The Access Board recommends that every attempt be made to meet accessibility requirements within public rights-of-way, but allows exemption from

Recommended Dimensions for Sidewalks and Walkways						
<i>Road Type</i>	Principal Arterial	Minor Arterial	Collector Arterial	Neighb. Collector	Local Residential	Commercial Access
<i>Right-of-Way</i>	30.5 m (100 ft)	25.6 m (84 ft)	18.3 m (60 ft)	18.3 (60 ft)	15.2-18.3m (50-60 ft)	18.3 m (60 ft)
<i>Width of Roadway</i>	4 Lanes	4 Lanes	2 Lanes	2 Lanes	8.5 m ± (28 ft. ±)	13.4 m ± (44 ft. ±)
Sidewalk Widths						
No buffer						
Desirable	2.4 m (8 ft)	2.4 m (8 ft)	1.8 m (6 ft)	1.8 m (6 ft)	1.5 m (5 ft)*	1.8 m (6 ft)
Minimum	1.8 m (6 ft)	1.8 m (6 ft)	1.8 m (6 ft)	1.8 m (6 ft)	1.5 m (5 ft)*	1.8 m (6 ft)
With planting strip/buffer	1.8 m (6 ft)	1.8 m (6 ft)	1.8 m (6 ft)	1.5 m (5 ft)*	1.5 m (5 ft)*	1.5 m (5 ft)*
With street trees, no buffer	3.0 m (10 ft)	3.0 m (10 ft)	2.4 m (8 ft)	2.4 m (8 ft)	—	—
Urban Center/ Business District	3.0-4.6 m + (10-15 ft) +	3.0-4.6 m + (10-15 ft) +	Varies	—	—	—
Location						
Desirable					Both Sides	Both Sides
Minimum	Both Sides	Both Sides	Both Sides	Both Sides	One Side**	One Side** or ***
Planting Buffer Width						
When Used						
Desirable	1.5 m (5 ft)	1.5 m (5 ft)	1.5 m (5 ft)	1.5 m (5 ft)	1.5 m (5 ft)	1.5 m (5 ft)
Minimum	1.2 m (4 ft)	1.2 m (4 ft)	1.2 m (4 ft)	1.2 m (4 ft)	1.2 m (4 ft)	1.2 m (4 ft)
* Provide 2.0 m (6.5 ft) minimum if mailboxes or other obstructions are located within sidewalk, so that a minimum clear width of 1.5 m (5 ft) is provided.						
** In areas where residential densities exceed 4 dwelling units per acre and where regular pedestrian access to commercial services is anticipated, sidewalks on both sides are recommended. For densities of 1 to 4 dwelling units per acre or less, sidewalks on both sides are preferred, but one side is the minimum recommendation. Also, sidewalks may need to be wider where there are designated school walking routes, parks, recreation centers, transit stops, or other common pedestrian origins and destinations. Check with local jurisdictions.						
*** If no sidewalk, provide delineated/striped walkways or shoulders (see Shoulders as Walkways in Rural Areas).						
Refer to local agency for specific design standards and requirements. Source: This table was compiled from information in several documents (see Resource Guide) and with input from the Advisory Group and other technical experts involved.						

Table 39

gradient requirements if certain sections of sidewalk or walkway follow the grade of the adjacent roadway and that roadway is steeper than the ADA allows.

Recommended Dimensions

In general, the width of a sidewalk or walkway needs to comfortably accommodate the volume of pedestrians normally using it. In high use areas, such as central business districts, sidewalks are generally 3.0 to 4.6 meters (10 to 15 feet) or wider to accommodate high pedestrian flows. Conversely, when excessively wide sidewalks are located in areas where there are low pedestrian volumes, the expansive pavement and empty-looking sidewalks may seem uninviting to pedestrians.

The spatial dimensions of people provided in the section of the guidebook called About Pedestrians can provide some insight into how wide a pedestrian walking area needs to be for a given number of people. The width of sidewalks and walkways provided may vary depending on pedestrian volumes, the roadside environment and land use setting, available space within the right-of-way, traffic characteristics, adjacent development, the characteristics of pedestrians using the facility, available funding levels, and local preferences.

Recommended dimensions for sidewalks and walkways along various types of streets are illustrated in Table 39. The table references common street system classifications and outlines the desirable and minimum dimensions recommended for sidewalks and walkways along each classification.

The dimensions listed in the table are guidelines. Dimensional requirements may vary within each local jurisdiction. It is necessary to consider each project on an individual basis to determine the best possible design solutions for pedestrians. For example, on a neighborhood collector that provides a high volume of pedestrian access to a school, park, or other popular destinations, it may be desirable to provide wider sidewalks than recommended in the table.

Passing, Waiting, and Resting Areas

Passing areas are required on all routes that are less than 1.5 meters (5 feet) wide. For more information, see Toolkit 2 — Accessibility.

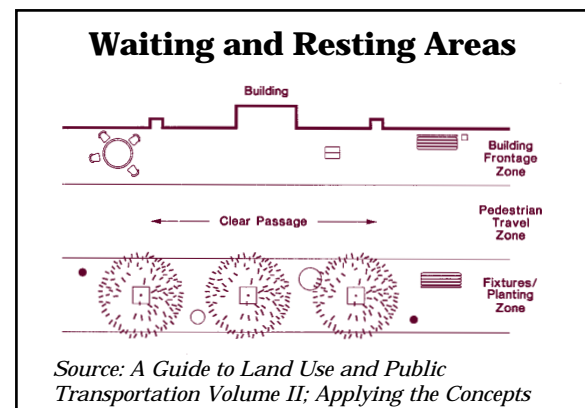

Figure 43

Waiting and resting areas along walkways provide welcome relief to pedestrians, particularly those who have mobility impairments, or lack stamina. Figure 43 illustrates typical dimensions of waiting and resting areas adjacent to a walkway or sidewalk.

Grades, Cross Slope, and Drainage

Sidewalks and walkways should be designed with maximum grades of 5 percent (1:20) where possible. The ADA requires sidewalks and walkways that serve as accessible routes of travel between public buildings, facilities and services to be designed to this maximum grade, and encourages all pedestrian travel ways to be designed to this maximum grade unless the adjacent road grade is steeper and there is no other alternative alignment for the walkway. Since sidewalk grades are generally designed to match the adjacent street system, it is recognized that in some cases it may be necessary to exceed this gradient where topographic conditions and other physical constraints are severe.

Sidewalks are typically constructed with a cross slope of 2 percent (1:50) maximum, which is also the maximum allowed for accessible routes of travel. The cross slope

facilitates positive drainage toward the street or adjacent planting buffer.

Drainage grates are best located outside the route of pedestrian travel. If this is not possible, the grate (as well as manhole covers, hatches, vaults and other utility coverings) should not have openings greater than 1.3 centimeters (0.5 inches) in width and should be mounted flush with the level of the surrounding sidewalk surface.

Side Slopes, Railings, and Walls

The design of elements adjacent to sidewalks and walkways can affect pedestrian comfort and safety as much as the design of the sidewalks and walkways themselves.

Side slopes next to sidewalks and walkways should generally not be steeper than 1:3. A level area approximately 1.2 meters (4 feet)

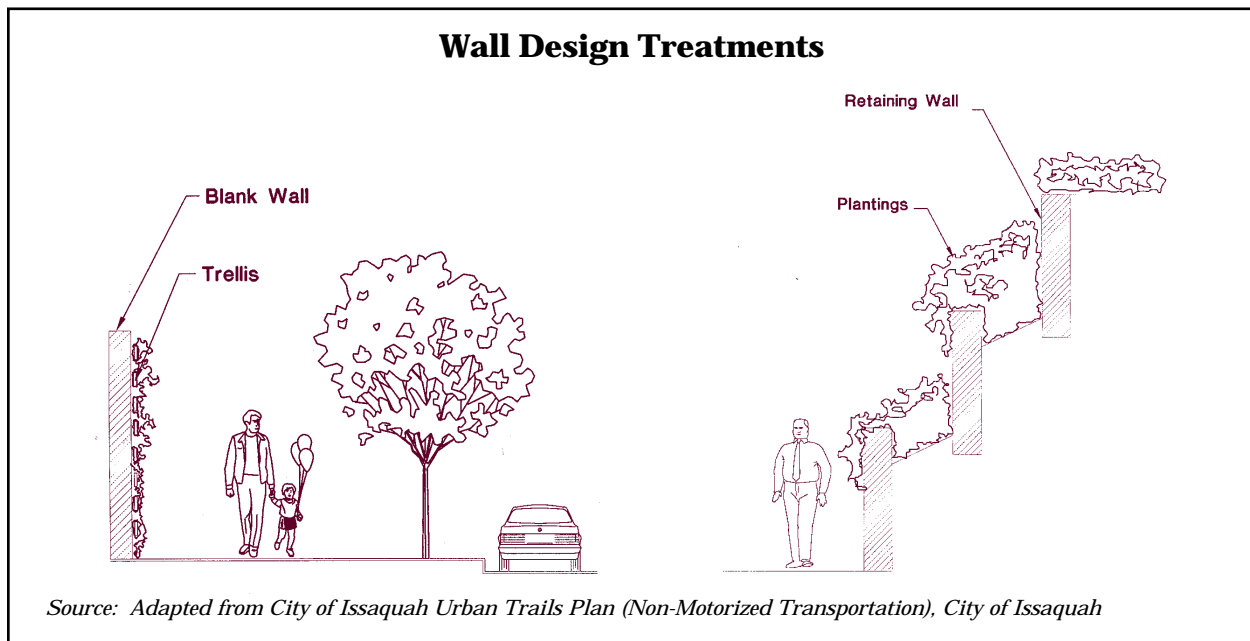

Figure 44

wide minimum is recommended for the sides of a sidewalk or walkway. When a vertical drop is more than 0.8 meters (30 inches/2.5 feet), exceeds a down slope grade of 1:2, and is located less than 1.2 meters (4 feet) from the edge of the walkway, railing needs to be installed along the extent of the grade drop.

The recommended height for railings adjacent to sidewalks and walkways to provide protection from vertical drops is 1.1 meters (3.5 feet). Railings adjacent to multi-use pathways are required to be a minimum of 1.4 meters (4.5 feet) tall. Railings are typically required to be designed with no opening large enough to allow passage of a 10-centimeter (4-inch) diameter sphere (*1994 Uniform Building Code, Volume I*). For additional design recommendations related to railings, refer to Toolkit Section 4 — Trails and Pathways.

Vertical walls or retaining walls adjacent to sidewalks and walkways can be an imposing force on passing pedestrians. Avoid high retaining walls by terracing back on the slope with lower walls (when space is available in the right-of-way or can be obtained). Design blank wall faces with an attractive finish and texture or screened with trellises and climbing plants. Figure 44 illustrates suggested wall design treatments.

Surfacing

Sidewalks and walkways in urban areas are typically constructed of Portland cement concrete (PCC), which provides a smooth, long-lasting and durable finish that is easy to grade and repair. Scoring patterns may be designed to match historic patterns within a neighborhood or district where appropriate.

Any material used for sidewalks and walkways needs to be slip-resistant and easy to maintain (smooth for snow removal and



Special paving in downtown Port Townsend.

able to resist buckling and cracking). Surfaces must be accessible, which is accomplished by meeting the “stable, firm, and slip-resistant” criteria of the ADA design guidelines.

Asphaltic concrete pavement (ACP) can be used as an alternative to PCC, but it generally has a shorter life expectancy (15 to 20 years versus 40 years for PCC). ACP is often used in low density residential areas or in less developed urban areas. Depending on the quality of design, construction, and drainage conditions, ACP sidewalks behind curbs sometimes tend to settle and wear down faster than PCC sidewalks. ACP is also more susceptible to deterioration by vegetation and requires more frequent maintenance. In areas, where walkways are aligned adjacent to shallow-rooted shrubs and trees, root damage to the pavement can result. Root barriers can provide an effective solution to this problem (see Toolkit Section 4 — Trails and Pathways).

Special districts and downtown streets often incorporate special paving into the design of sidewalks and pedestrian areas, such as stamped or colored concrete, brick, or other unit pavers. Brick and unit pavers need to be

installed to provide a smooth level surface. Paving units are more difficult to maintain over the long term. Special paving bands that contrast with the sidewalk surfacing can also be installed to alert pedestrians of upcoming driveway crossings.

In rural areas, alternative surfacing, such as compacted crushed rock or unpaved compacted earth, may also be acceptable for certain walkways. These surfaces are typically not accessible to people using strollers or wheelchairs unless very smooth and well-compacted. Recycled pavement grindings can also provide an inexpensive surfacing material and are easy to grade (especially during the summer when the heat helps pack and bind the material).

Sometimes sidewalks and walkways within the right-of-way are constructed as boardwalks with wood decking, as structures over elevation drops or wet areas. Design considerations related to boardwalks and trestles are provided in Toolkit Section 7.

Street Separation and Edge Treatments

Planting Buffers

Sidewalks alongside roadways are often separated by planting strips consisting of natural vegetation or landscaping that create a buffer from the noise and splash of moving vehicles. Planting buffers (also referred to as planting strips, landscape strips or buffers, and nature strips) are generally considered to be a very effective separation treatment between walkways and streets in all types of settings. The added separation of a planting buffer helps a pedestrian feel more comfortable when walking along the street. Planting buffers can be landscaped in a

variety of ways to aesthetically enhance the streetside environment. (Refer to *Landscaping and Street Trees*.)

Planting buffers can be raised and bordered by curbing or developed at the same grade level

Advantages and Disadvantages of Planting Buffers

Advantages

- Separation between pedestrians and street traffic
- Sidewalk can be at a constant level grade across driveways, avoiding dipping at every driveway cut
- Area for drainage runoff and water quality treatment
- Space to locate street furniture, signs, utility and signal poles, mailboxes, parking meters, fire hydrants and other elements outside the clear space of the walkway (see Figure 46)
- Aesthetic enhancement, increasing the appeal of the walkway and improving the pedestrian environment
- If wide enough, can be planted with larger trees that will provide shade and wind protection; 1.5 meters (5 ft) minimum width recommended for tree planting
- Typically a lower cost solution for separation, if space is available

Disadvantages

- Maintenance is required, and varies depending on the type of landscaping selected
- If not designed and maintained properly, landscaping may hinder visibility and cause security problems
- Root growth can sometimes damage adjacent paved surfaces if not protected

Table 40

as the roadway. It is recommended that planting buffers be a minimum of 1.5 meters (5 feet) in width where street trees are proposed. (Check with your local agency.) In areas where there is limited space or right-of-way, the width of the planting buffer can be reduced, or eliminated and provided again where there is more space or right-of-way available. Figure 45 illustrates a planting buffer between a sidewalk and street. Advantages and disadvantages related to the use of planting strips as a separation treatment next to walkways are listed in Table 40.



Walkway along suburban street with planting buffer.

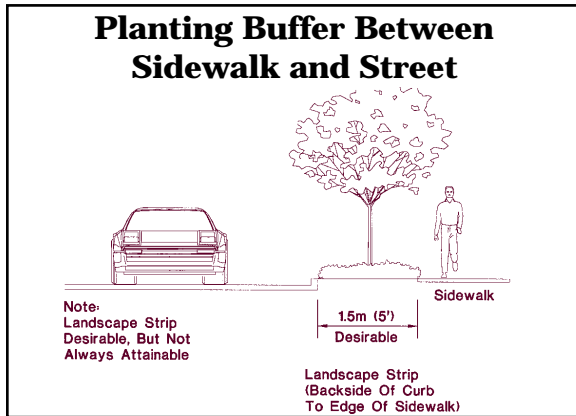

Figure 45

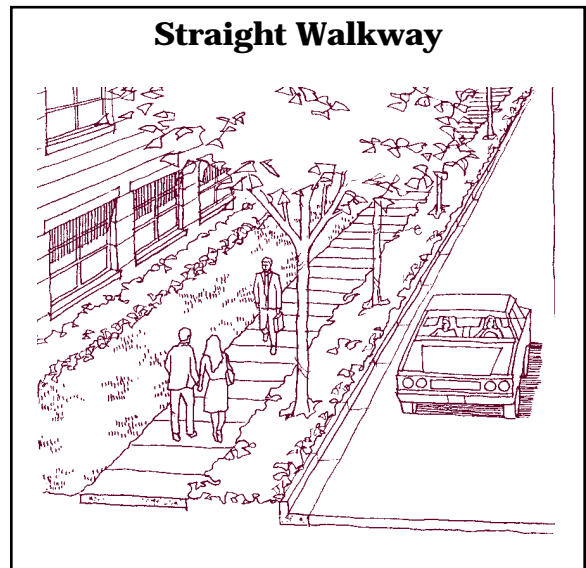

Figure 47



Figure 46

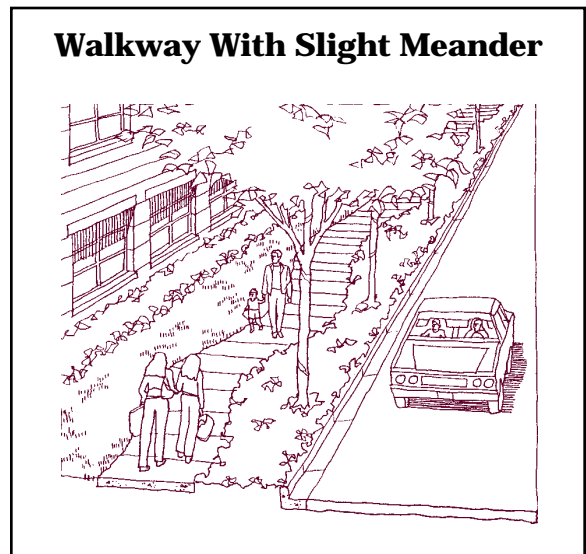

Figure 48

Meandering Walkways

Sometimes, a meandering walkway is constructed, creating a planting strip with an informal, curving appearance. Although meandering walkways may look nice, they are not the most efficient way of getting people from one place to another. They may also be misleading to pedestrians with sight impairments who need better predictability. If a meandering walkway is desired, minimize the number of curves to avoid creating a route that is too awkward and indirect. Meandering walkways can provide the advantage of design to avoid obstacles such as telephone poles, utility features, signs, etc. Figures 47 and 48 illustrate a straight walkway and a walkway with a slight meander.

Ditches or Swales as Separation

On many rural roadways, an open ditch is located along the edge to provide conveyance and treatment of stormwater runoff. Where there is sufficient space within the right-of-way, the sidewalk or walkway can be located behind the ditch, providing a buffer area between motor vehicle traffic and pedestrians. In situations where a ditch or swale is used to separate a sidewalk, the separation area

needs to be a minimum of 1.5 meters (5 feet) wide. Ditch side slopes should generally not exceed a 1:3 slope. A sidewalk separated from the roadway by a ditch is illustrated in Figure 49.

Curb and Gutter / Vertical Curb

Curb and gutter provides two primary functions: control of stormwater drainage, and vertical barrier or separation between motor vehicles and pedestrians. Curbs are often required on streets with higher volumes and speeds and where efficiently controlled drainage is a necessity. Curb and gutter or vertical curb are commonly required for urban streets.

Curb and gutter and vertical curb provide a non-mountable barrier adjacent to street parking that keeps cars from parking on adjacent sidewalks. Curbs provide a physical barrier between moving vehicles and pedestrians. Curbs can be costly to construct, so they may not be practical to build in all areas. Curbs also have an urban-looking appearance, which may not be desirable in some areas, where a more natural-looking roadside appearance is desired. Figure 50 illustrates a sidewalk adjacent to curb and

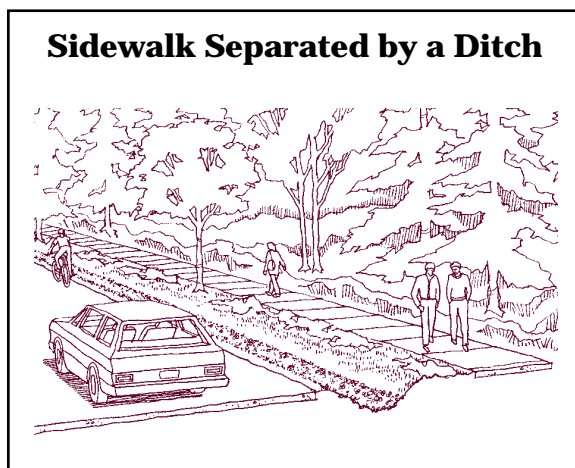

Figure 49

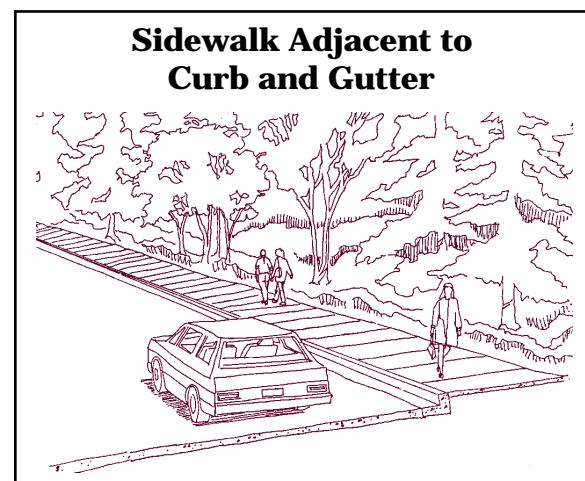

Figure 50

Vertical Curb Adjacent to a Planting Strip

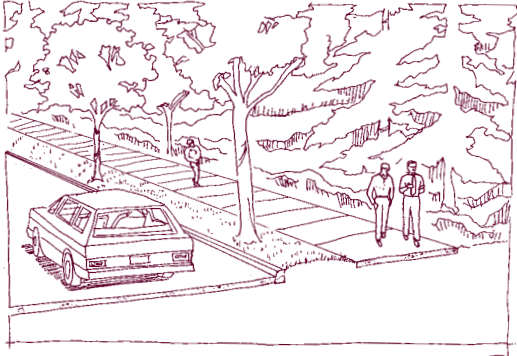

Figure 51

gutter, and Figure 51 illustrates a vertical curb adjacent to a planting.

Rolled Curb (Strongly Discouraged)

Rolled curb is a mountable type of curb design often used in suburban neighborhoods. Rolled curb provides an advantage to developers in that it eliminates the need for individual driveway cuts. However, rolled curb often presents a **problem** when used along sidewalks. Since rolled curbs are easily mountable by motor vehicles, drivers often park up on top of the curb and block the sidewalk. Additionally, rolled curbs do not provide as strong a barrier as vertical curb between pedestrians and vehicles. Figure 52 illustrates a sidewalk with rolled curb.

Vertical curb or curb and gutter constructed using standard designs provide a non-mountable barrier adjacent to sidewalks that is more desirable than rolled curb adjacent to pedestrian travel ways.

Sidewalk With Rolled Curb

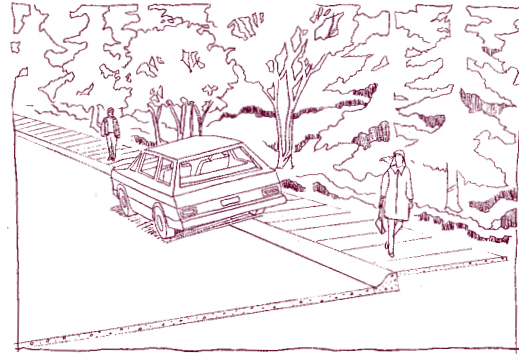

Vehicles can park on sidewalk, blocking pedestrian travel.

Figure 52

Extruded and Timber Curbing

In suburban and rural areas, it is common to see extruded curb, timbers, or other linear devices used to separate roadways from walkways. These facilities have been placed along paved or unpaved walkways that are on the same grade as the adjacent roadway. Extruded curb and timbers provide a relatively low cost vertical barrier between vehicles and pedestrians. However, there are several drawbacks to this type of edge treatment, and their use may be inappropriate for most applications. Strong consideration of the following problems is recommended before installing extruded or timber curbing:

- Extruded curb and timbers breakdown easily when hit by motor vehicles, increasing the need for frequent repair and replacement. Sometimes this type of curbing has difficulty staying attached to the pavement surface.
- Breaks in the curbing are necessary at pedestrian crossing points, driveways, and intersections.

- These may become a barrier to drainage if designed and located improperly and tend to collect litter, fallen leaves, and debris along the roadside (breaks in the curbing at strategic locations will help, but maintenance is still more difficult than other types of curbing).
- Unless backfilled, extruded or timber curbing can become an obstacle to pedestrian and bicycle travel as a raised element on the surface. **The use of this type of curbing adjacent to bicycle lanes is strongly discouraged, unless placed outside the clearance area at the outside of edge of the bike lane**, as shown

in Figure 53. A minimum clearance of 0.6 meters (2 feet) adjacent to a 1.5-meter (5-foot) bike lane is recommended, creating a total lane width of 2.1 meters (7 feet). It is recommended that the pedestrian travel way on the other side of the curb be a minimum of 1.5 meters (5 feet) wide.

Raised Pavement Markers

Raised pavement markers are small plastic devices that are glued to the pavement surface as a delineation technique at the edge of roadways. State law **strongly discourages** the use of raised pavement markers along the right edge line because they are obstacles for bicycles (WAC 468-95-035 pursuant to RCW 47.36.280). Raised or recessed pavement markers can be used along right edge lines on the taper in lane transition sections, on approaches to objects, and within channelization at intersections. Raised or recessed pavement markers can only be used along right edge lines at other locations where an engineering study has determined that markers are essential to preserving pedestrian, bicycle, and motor vehicle safety. At the initiation of the engineering study, local bicycling organizations, the regional member of the state bicycling advisory committee, and the WSDOT Bicycle and Pedestrian Program Manager shall be notified for review and comment.

Position and spacing of markers must be determined by engineering judgement taking into consideration their effect on bicycle, pedestrian, and motor vehicle safety. Existing raised pavement markers must be removed at the time roadways are being resurfaced or earlier, at their option. State law requires this standard to remain in effect unless the legislative authority of the local governmental body finds that special circumstances exist affecting vehicle and pedestrian safety that

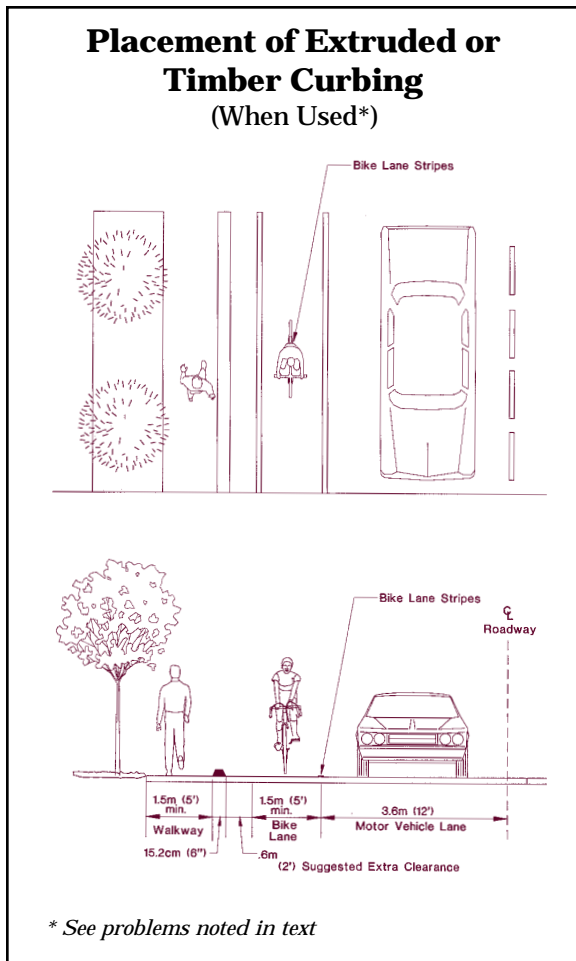

Figure 53

warrant a site-specific variance to the standard.

Bike Lanes as Separation

When bike lanes are located between the street and the pedestrian travel way, they provide a buffer between pedestrians and motor vehicles. It is recommended that the width of the bike lane comply with WSDOT standards. The adjacent pedestrian travel way be raised and separated by curb (in urban areas), or at a minimum, a white edge stripe is used at the outside edge, between the bike lane and the shoulder area to be used by pedestrians (in rural areas). Figure 54 illustrates how a bike lane provides a buffer between pedestrians and motor vehicles.

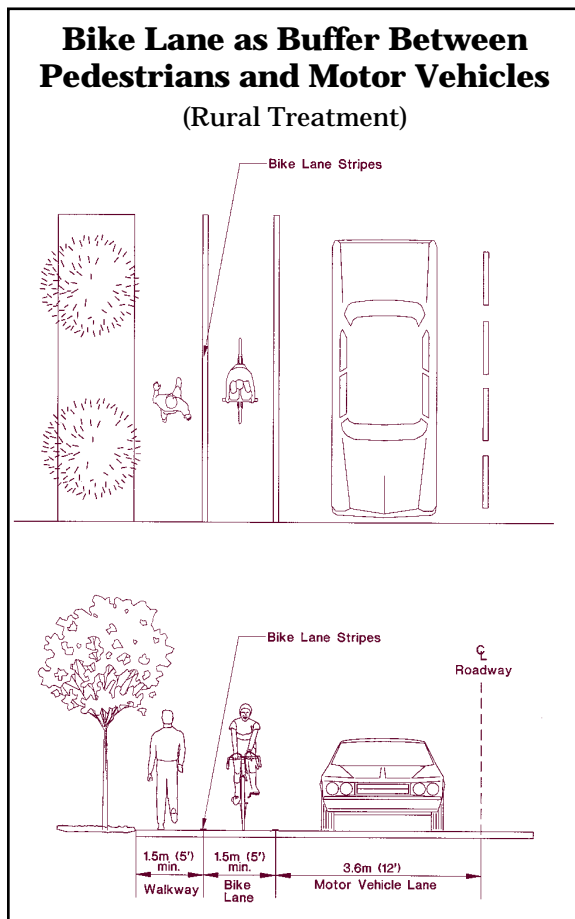

Figure 54

Concrete Barriers

Concrete barriers (also called New Jersey barriers) are occasionally used as a protective separation devices between roadways and pedestrian travel ways, although their primary purpose is to shield and direct vehicles away from potential hazards.

Concrete barriers have some of the same potential drawbacks as those listed for extruded and timber curbs. Concrete barriers cost significantly more than curbing, and may not be the most visually appealing solution. When concrete barriers are used for separation between roadways and multi-use pathways, they need to have a minimum height of 1.4 meters (4.5 feet) or have a securely attached vertical railing at that height. Refer to the WSDOT *Design Manual* for design standards for concrete barriers and railings. Also, the ITE manual, *Design and Safety of Pedestrian Facilities*, provides some guidance about when it is necessary to provide pedestrian barriers.

Vertical concrete surfaces adjacent to pedestrian facilities should be smooth to avoid snagging of clothing or abrasive injuries from contact with the surface. Bolts or other protrusions from walls, railings, or barriers need to be cut off flush to the surface or recessed.

Street Furnishings, Utilities, and Related Clearances

Urban streetscapes should be carefully designed in order to provide adequate space for furnishings and utility facilities, outside the main travel way used by pedestrians. A clear travel way of 0.9 meters (3 feet) minimum is recommended on all sidewalks

5

Sidewalks and Walkways

and walkways and required by the ADA for all accessible routes of travel. This clearance is only suitable where pedestrian volumes are low. Where pedestrian volumes are moderate to high, this clearance should be increased to the maximum obtainable or the full width of the sidewalk. Obstacles, such as signs, street furniture, and newspaper stands, should be

placed off to the side of the travel way, in the “fixtures/planting zone,” as discussed later in this toolkit.

The vertical clearance needed for sidewalks and walkways is typically 2.4 meters (8 feet), as illustrated in Figure 55. The ADA requires that “*objects protruding from walls (e.g. signs,*



Figure 55

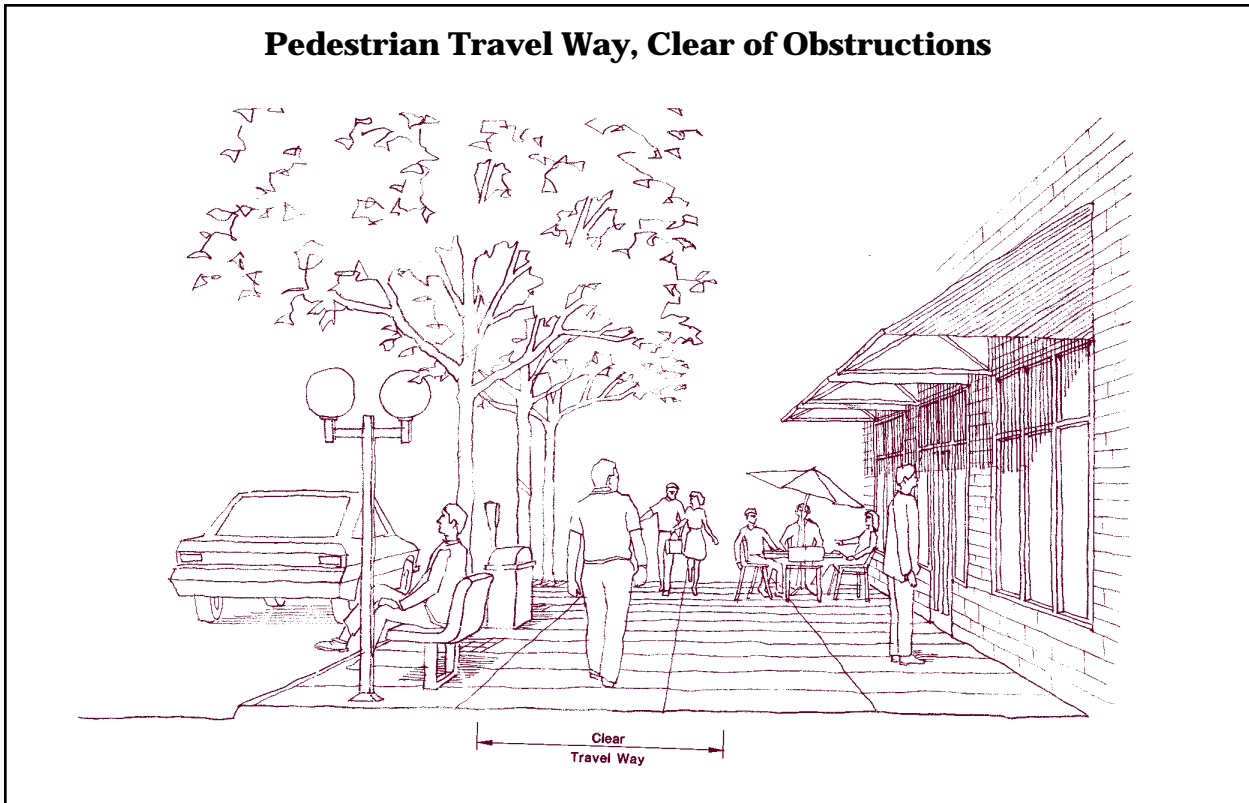

Figure 56

fixtures, telephones, canopies) with their leading edge between 685 and 2030 mm (27 and 80 inches) above the finished sidewalk shall protrude no more than 100 mm (4 inches) into any portion of the public sidewalk."

Traffic signs located directly adjacent to or within the sidewalk need to be mounted and tree branches need to be pruned high enough so that there is a minimum of 2.1 meters (7 feet) of clearance from ground level to the bottom of the sign. Informational and directional signs for pedestrians can be lower, if located a minimum of 1 meter (3 feet) from the sidewalk. A typical pedestrian travel way, designed to be clear of obstructions, is illustrated in Figure 56.

Landscaping and Street Trees

The use of planting buffers for separation between walkways and streets was discussed previously in this toolkit. Landscaping and street trees in planting buffers and along streets can greatly enhance the pedestrian environment and provide shade and shelter, but careful thought needs to be given to the selection of trees and shrubs to be installed.

Using low height shrubs and upward branching trees will maintain visibility and sight distance at intersections, driveways, crossings, and other critical areas along the street system. It is also important to consider how high and wide the shrubs and trees will be at maturity.

Street trees are typically spaced evenly along the street, ranging from 7.6 to 15.2 meters (25 to 50 feet) apart, depending on the size of the tree at maturity. Trees can also be placed informally and clustered in areas. Do not locate trees where they will be an obvious obstruction to visibility.



Street trees enhance pedestrian environments.

Selection of plant material also needs to consider the availability of irrigation water, ways to minimize maintenance, and community preferences for landscape materials (such as the use of native species and informal plantings versus ornamental or formal landscapes).

When tree wells are installed on urban sidewalks, they should be placed out of the pedestrian travel way. Tree wells can vary in size depending on the width of the sidewalk. Tree grates adjacent to or within sidewalks need to meet the accessibility requirements of the ADA — top mounted flush with grade and no openings larger than 1.3 centimeters (0.5 inches) in diameter.

Additional design guidelines related to landscaping adjacent to pedestrian facilities, including recommendations to minimize root damage to adjacent paved areas, are provided in Toolkit Section 4 — Trails and Pathways. For additional information, see the WSDOT *Roadside Management Manual*, M25-30.

Lighting

Lighting of the street system, including adjacent sidewalks, walkways, and bike lanes, increases security and pedestrian safety and comfort. Typically, the street lighting system in urban areas sufficiently serves pedestrian sidewalks and walkways along the street. It is important to consider the security and comfort of pedestrians, when designing a street lighting system.

Where a new lighting system is being introduced either to replace or supplement the existing street lighting system, it may be possible to incorporate light posts and fixtures that are more pedestrian friendly (shorter and more in scale with pedestrians and with less obtrusive and harsh light sources). Additional lighting may be necessary at pedestrian crossing points, intersections, entrances to buildings, and other areas to supplement existing street system lighting.

It is generally recommended that a level of lighting between 0.5 and 2.0 footcandles be provided along pedestrian travel ways, depending on conditions. Check with your local agency for applicable design standards. Also, refer to the standards and design guidelines of the Illuminating Engineering Society of North America. (Note: state regulations require that exterior accessible routes of travel outside of buildings be illuminated with an intensity of not less than 1.0 footcandle on the surface of the route during any time the building is occupied (WAC 51-30).

Signing

Pedestrian facilities generally require minimal signing. Most regulatory and warning signs are directed at motor vehicle traffic along streets and prior to crossings. Directional and

informational signing installed for motor vehicle use may not adequately serve pedestrians, so care should be taken to identify key origins and destinations, such as schools, parks, libraries, museums, entertainment centers, and shopping districts.

Distances to these origins and destinations can be given in blocks, average walking time, or other measurements meaningful to pedestrians. The provision of walking maps, including information about transit routes, make it easier for pedestrians to find their way around a new urban environment. Some cities and towns have provided maps inscribed in the sidewalk or on manhole covers. Information for pedestrians can also be displayed on kiosks or other designated areas.

Signs should be easy to read and understand with simple phrases and graphics. Letters and symbols need to be bold with high contrast to the background. Generally, light letters and symbols against dark backgrounds are easiest to read.

Signing needs to be understood by the vast majority of the population, including non-English speaking people and children. The use of internationally recognized symbols can be an effective way to identify features to all pedestrians.

Sidewalks in Business Districts and Downtowns

Sidewalks in central business districts and downtown areas need to be designed to efficiently accommodate heavy volumes of pedestrian traffic. Streetscapes in these areas often function for multiple purposes, and the streetside generally consists of three zones: the building frontage zone; the pedestrian

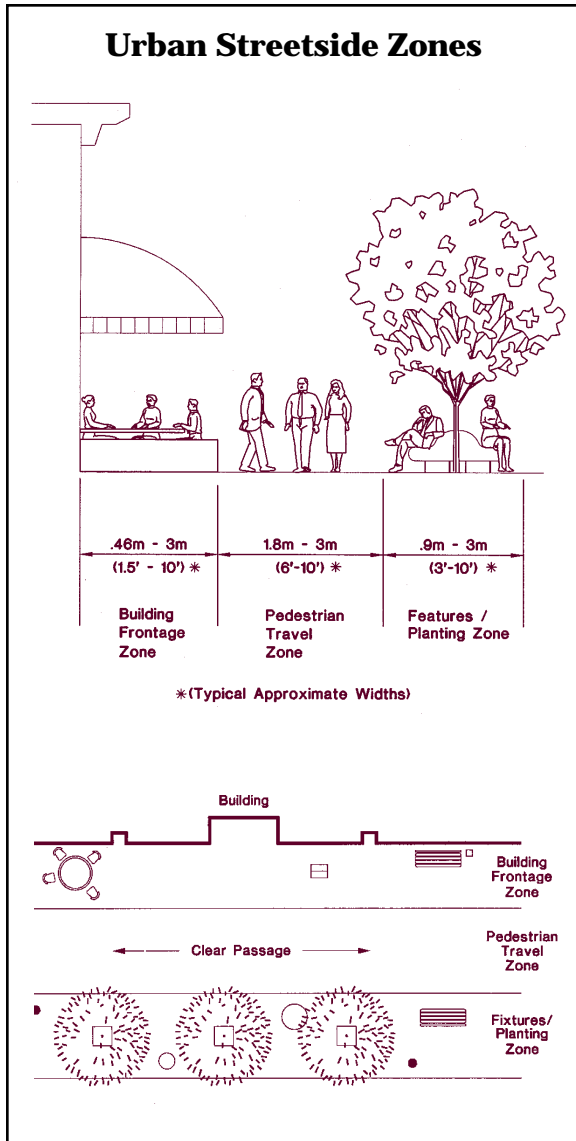

Figure 57

travel zone; and the fixtures/planting zone. These three zones and their typical approximate widths are illustrated in Figure 57. Please note that these widths may vary and may be wider, depending on specific circumstances within the right-of-way.

Building Frontage Zone

The building frontage zone is the area where people enter and exit buildings adjacent to the street right-of-way. People don't feel

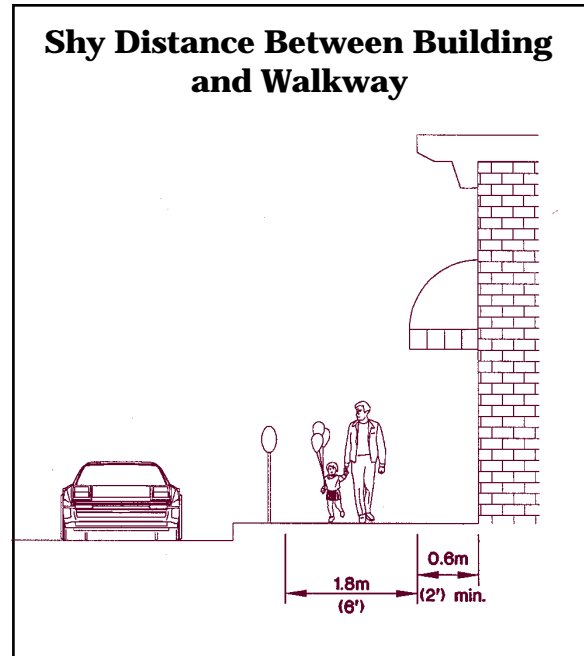

Figure 58

comfortable moving at full pace directly adjacent to the building wall, so this area is to the side of the primary travel area. It is also an area where pedestrians may window shop or move more slowly, restricting other pedestrians. On some streets, the building frontage zone may become a pedestrian plaza, outdoor cafe, or gathering area in front of some buildings, depending on available space within the right-of-way. For this reason, the building frontage zone can vary in width from approximately 0.6 to 3.0 meters (2 to 10 feet) or more. At a minimum, people prefer about 0.6 meters (2 feet) of “shy” distance when walking adjacent to buildings, as illustrated in Figure 58.

Pedestrian Travel Zone

The pedestrian travel zone is the area where most pedestrians travel on the downtown sidewalk. The minimum required clear space for this zone, free of obstacles and protrusions, is 0.9 meters (3 feet) if the travel way is an

accessible route, but it is desirable to provide as wide a clear space for pedestrian travel as possible, particularly in urban areas where there are higher volumes of pedestrians. A 1-meter (3-foot) wide area is not sufficient for use by more than one person. For this reason, the pedestrian travel zone on downtown streets should typically be 1.8 to 3.0 meters (6 to 10 feet) wide or greater in areas where high volumes of pedestrians are anticipated.

Fixtures/Planting Zone

The fixtures/planting zone is located directly adjacent to the street and provides a buffer between the street traffic and the pedestrian travel zone. Consolidate or congregate, where possible, utilities, street furniture, and other elements within this zone to minimize obstacles in the pedestrian travel way and improve the visual appearance of an area. Examples of consolidating include putting more than one utility on a pole system or more than one sign on a post, and clustering furnishings within the planting strip or to one side of the primary walking area. The approximate dimension for this zone is typically 0.9 to 3.0 meters (3 to 10 feet or 4 feet, if landscaped), depending on the dimensions of the right-of-way and the other



Streetscapes in downtowns need to be designed to accommodate heavy volumes of pedestrians.

two zones. Curb extensions provide opportunities to place benches and furnishings.

On some urban streets with limited right-of-way, it may be necessary to reduce the widths of the building frontage and fixtures/planting zones, or eliminate them altogether. The provision of at least a pedestrian travel zone with a minimum width of 1.8 meters (6 feet) is recommended in this case.

Shoulders as Walkways in Rural Areas

Wide shoulders along roadways can also function as walkways, particularly in rural areas. Local agencies sometimes consider paved or unpaved walkways and roadside shoulders used for pedestrian travel in urban areas to be interim solutions until funding permits construction of full sidewalk improvements. In rural areas, where funding for pedestrian improvements can be limited,



Shoulder walkway in rural area.

walkways and shoulders may be acceptable as a longer-term solution, particularly if the alternative is no pedestrian facilities at all.

Recommended Shoulder Dimensions

A 0.9 to 1.5-meter (3 to 5-foot) wide shoulder adjacent to a bike lane and on local roads with lower traffic volumes (less than 400 ADT) may provide sufficient walking space for a single pedestrian. But shoulders that accommodate groups of pedestrians, such as school children walking to and from school, and that are located on major collectors and arterials (with more than 2,000 ADT) need to be wider (WSDOT *Design Manual*).

At a minimum, *A Guidebook for Student Pedestrian Safety* recommends 1.5-meter (5-foot) wide shoulders on both sides of the road for school walk routes or at least 2.4 meters (8 feet wide) if constructed on only one side. Shoulder areas located at school bus stops need to be widened to accommodate children waiting at the roadside for the bus (refer to Toolkit Section 3 — Children and School Zones).

The WSDOT *Design Manual* states that in rural areas with heavy pedestrian use, an additional pavement width of up to 1.2 meters (4 feet) is added to the state highway to obtain a maximum shoulder width of 3.0 meters (10 feet). Local standards for shoulder widths may vary, but shoulder widths should not be narrower than that allowed by local, state, or federal standards. A typical walking shoulder is illustrated in Figure 59.

Shoulder Surfacing and Delineation

Shoulders may be paved or unpaved. A high visual and tactile contrast is desirable in order

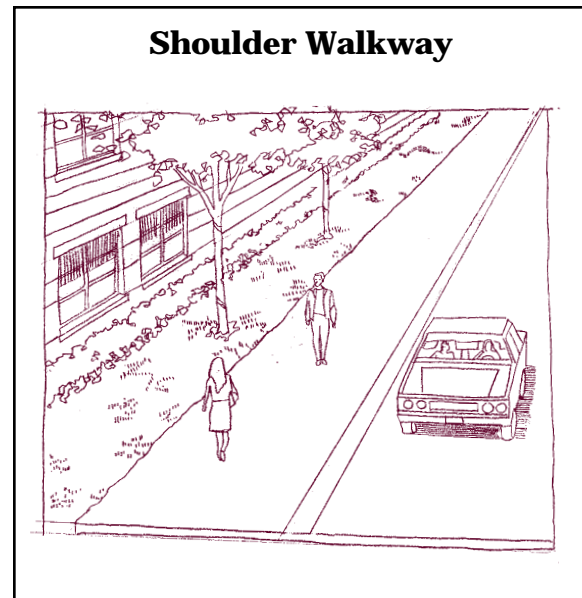

Figure 59

to clearly define the pedestrian area and discourage drivers from straying onto the shoulder. If paved shoulders are to be used by pedestrians, they should be well-marked. One design solution that helps delineate the shoulder walking area is the use of a contrasting paving material or color for the paved shoulder, or a contrasting strip separating the shoulder from the street.

Shoulders for walking may also be delineated by a 10-centimeter (4-inch) wide white stripe at the edge of the vehicular travel lane or bike lane. Alternative striping solutions may also be acceptable, such as wider than standard white fog lines or edge stripes, dashed stripes, angled stripes, and other techniques.

Raised pavement markers are generally not recommended as an edge line delineation treatment because they create an obstacle to bicycle travel (see discussion earlier in this toolkit). Pavement texturing techniques, such as chip seal markers, can be used to delineate shoulders and provide both a tactile and audible warning to pedestrians and motorists.

Unpaved shoulders consisting of compacted crushed rock or gravel materials can also be installed and offer a contrasting material adjacent to asphalt or concrete roadway paving. Crushed rock and gravel shoulders are difficult to travel on unless extremely well-compacted. Compacted earth or low-growing grass shoulders can also provide a walking area for pedestrians, but they function poorly during wet weather. Unpaved shoulders can be less costly to install, but are usually more costly to maintain.

Operational Considerations Related to Shoulders

Shoulders are not really appropriate as accessible routes of travel (see Toolkit 2 — Accessibility). In areas where an accessible route of travel is needed along the roadside to provide access between public buildings or facilities, a full sidewalk or walkway improvement, raised and separated from the street, should be constructed.

Shoulders that are intended to be used by pedestrians should not be used as roadside parking lanes, not even for short-term or temporary periods (except during emergencies). Provide signs to prohibit parking along shoulders that are wide enough for cars to park on them (1.8 meters [6 feet] or wider). Enforce parking restrictions to ensure that vehicles do not block the pedestrian travel way.

Shoulders that are heavily relied upon by pedestrians for a regular walking route will not function adequately if they double as bike lanes. Separate bike lanes are recommended. If a multi-use pathway is to be provided within the right-of-way, it should be designed to meet or exceed WSDOT standards.

Recommendations for Walking Shoulders

- Best used in rural areas with lower pedestrian volumes
- 0.9 to 1.5 meters (3 to 5 feet) wide minimum for roadways with less than 400 ADT
- 1.5 meters (5 feet) minimum, both sides for school walking routes
- 2.4 meters (8 feet) minimum, at least one side for school walking routes and roadways with over 2,000 ADT
- Can be paved or unpaved, but high visual and tactile contrast from adjacent roadway is best
- Sign to prohibit parking
- Double use as bike lanes not recommended (unless designed as a multi-use facility in accordance with local, state, and federal standards)

Table 41

Table 41 summarizes a few of the important concerns related to roadside shoulder design for pedestrian use.

Bicycles on Sidewalks

Generally, designating sidewalks for bicycle travel is not recommended even if the sidewalks are wider, for the following reasons:

- Motorists do not expect to see bicyclists traveling on sidewalks and may pull out of intersections or driveways and collide with a bicycle unexpectedly.

- The potential for conflicts between bicyclists and pedestrians greatly increases with shared use.
- Pedestrian movements are often unpredictable for an approaching bicyclist from behind (especially those of small children), and pedestrians cannot always predict the direction an oncoming bicyclist will take.
- Sidewalks are usually two-way facilities and bicyclists are encouraged to travel one-way, with the flow of traffic.
- Sight distances are more limited at driveway crossings.
- There also may be limited sight distance and clearances due to signs, utilities, landscaping, fencing, or other obstacles beside or protruding into the sidewalk.

Street Design Considerations

Since sidewalks and walkways are developed as integral components of street and roadway systems, there are several important aspects related to street design that affect pedestrians.

Parking Along Streets

On-street parking provides a buffer zone between the roadway and the sidewalk. It also narrows the appearance of streets, reducing vehicle speeds. On-street parking provides opportunities for people to access the sidewalk directly from their vehicles and increases street activity. For these reasons, on-street parking is often supported in business and shopping districts. Figure 60

On-Street Parking as a Buffer Between Street and Pedestrian Walkway

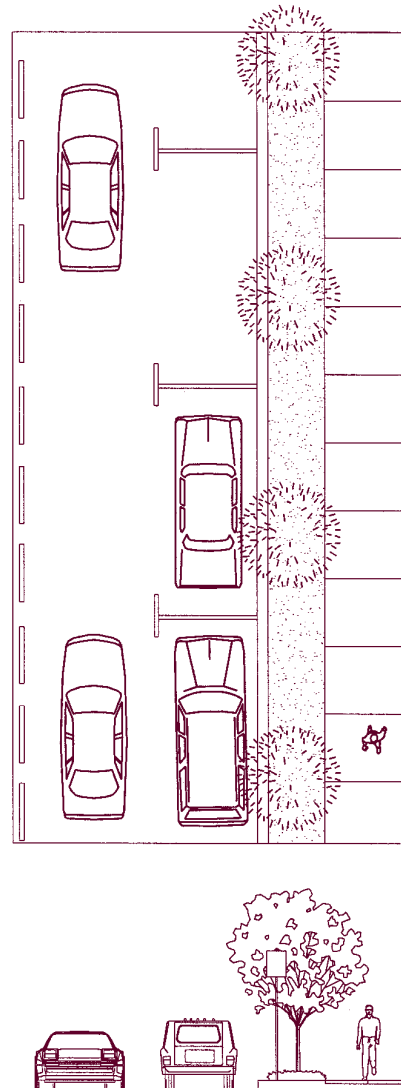

Figure 60

illustrates how on-street parking provides a buffer between street traffic and pedestrians.

In some cases, on-street parking may present problems when there is not enough space for people to safely get out of their cars or walk

between cars. On-street parking on roadways where there are no adjacent pedestrian facilities or undelineated crossings is not desirable because pedestrians may be forced to walk in the roadway to get to their destination or may cross at several points along the roadway rather than at a single point. A common cause of collisions is the lack of visibility of pedestrians entering the roadway from between parked cars. An example of this is when on-street parking is provided informally adjacent to a park or ballfield where there are high numbers of children prone to darting out into streets and not aware of traffic conditions.

Parallel parking stalls need to provide adequate space for pedestrian movement around the parked car without forcing pedestrians out into the stream of traffic and to prevent car doors from opening into bike lanes. Typical dimensions of 2.7 meters (9 feet) wide by 7.3 meters (24 feet) in length (provides space in between cars) are recommended for on-street parallel parking stalls (check local standards).

When on-street parking is provided, adjacent pedestrian walkways and clearly identified street crossing points are also necessary. On-street parking or loading zones that are too close to intersections and mid-block crossings can block views of pedestrians. Parking areas should be set back from intersections and crossings to allow pedestrians to see oncoming traffic. Refer to Toolkit Section 6 — Intersections, for recommended set back distances for on-street parking near pedestrian crossing points. Fencing can be installed to channelize pedestrians to crossing points at specific entrances, but it should be designed and placed carefully so as not to become an obstacle to pedestrian travel. Bulb-outs and curb extensions also help to define pedestrian crossing points.

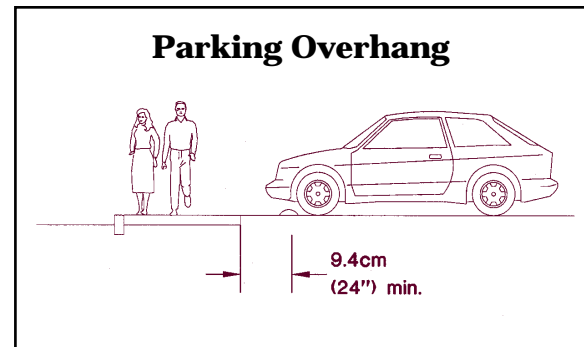

Figure 61

When perpendicular parking stalls are located adjacent to sidewalks, wheel stops or curbing should be constructed to eliminate vehicle overhang that reduces usable sidewalk area. Figure 61 illustrates this treatment.

Access Management and Driveways

Most pedestrian/motor vehicle collisions on busy streets occur at points of intersecting movements, such as intersections, driveways, and alleys. Unlimited vehicle access on roads increases the level of conflicts between pedestrians walking along the roadway and cars entering or leaving the roadway. Pedestrians crossing the roadway need gaps in the traffic stream, but with unlimited access, vehicles entering the roadway quickly fill the available gaps. Pedestrian access to transit may also be complicated by excessive driveway access points creating obstacles on their way to the bus stop.

Table 42 lists access management techniques as well as several benefits for pedestrians that result from access management. Figure 62 illustrates how controlled access and limited driveways reduce conflict points between pedestrians and motorists. The level of access management and its relationship to providing pedestrian facilities along state highways is described later in this section.

Access Management

Techniques

- Reducing the number of existing driveways or consolidating driveways to parking areas and businesses
- Providing raised or landscaped medians or concrete barriers to control turning movements from the street (with these treatments, it is important to provide accessible pedestrian crossing opportunities with breaks in the medians or barriers at suitable crossing points)

Benefits

- The number of conflict points is reduced (particularly with the use of center medians to reduce the number of conflicts between left-turning vehicles and pedestrians)

- Pedestrian crossing opportunities are enhanced with an accessible raised median and fewer conflicts with turning cars
- Accommodating people with disabilities becomes easier with the reduced need for special treatments at driveway cuts
- Traffic volumes may decrease if local traffic can use other available routes (note that volumes may increase if the route becomes more efficient for vehicles to use)
- Improved traffic flow may reduce the need for road-widening, allowing more space within the right-of-way for use by pedestrians, bicyclists, and enhancements and maintaining fewer travel lanes to cross at intersections

Source: Adapted from Oregon Bicycle and Pedestrian Plan

Table 42

Driveways that cross sidewalks and walkways need to be carefully designed to minimize conflicts between pedestrians and vehicles. For design recommendations related to driveway design (for both commercial and residential sites), refer to Toolkit 10 — Site Design for Pedestrians.

Access to Transit

The level of transit use often depends on the extent of improvements provided for pedestrians. Transit stops are provided in both urban and rural areas, and often pedestrians rely heavily on access to transit as their primary mode of transportation. Sidewalks, walkways, crossings, and other pedestrian facilities adjacent to and near transit stops need to be carefully planned and

well designed as a collaborative effort between the transit agency and the public works and traffic engineering departments of the local jurisdiction. Design recommendations related to transit stops and facilities are provided in Toolkit Section 9 — Pedestrian Access to Transit.

Benefits and Disadvantages of One-Way Streets for Pedestrians

One-way streets can provide certain benefits to pedestrian travel if appropriately implemented. However, when they are designed to increase traffic speeds, they create an unfriendly and uninviting environment for pedestrians. Some of the benefits and disadvantages related to the use of one-way streets are described in Table 43.

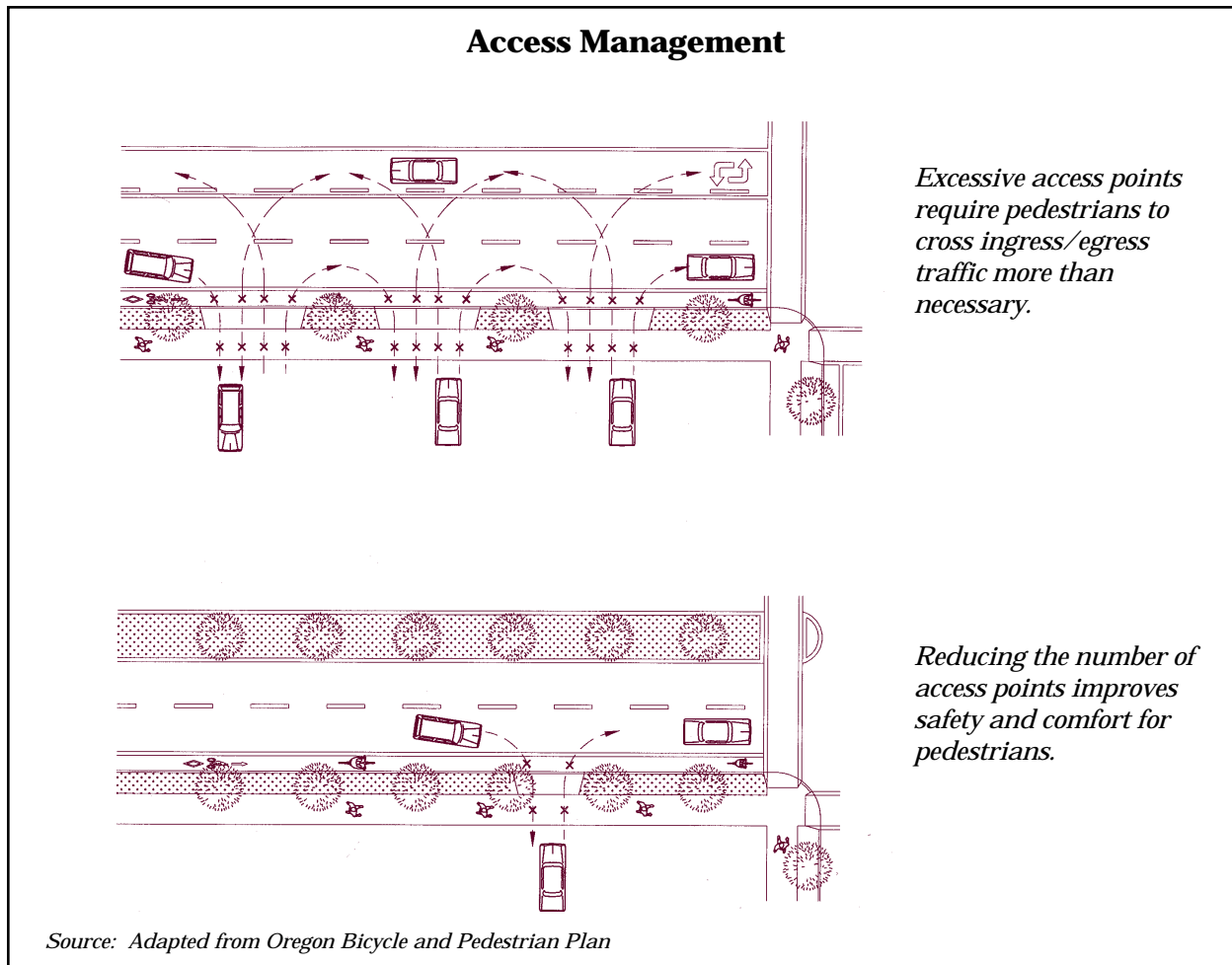

Figure 62

When considering conversion to a one-way street system, communities need to consider all the potential implications. Additional information that may be helpful to communities in considering whether or not to convert to a one-way street system is available in the *Florida Pedestrian Planning and Design Guidelines* and the *ITE Traffic Engineering Handbook*.

Pedestrian Facilities Along State Highways

State Highways as Main Streets

In many small towns and cities, state highways serve as the main street and primary arterial through the center of town. They function as the major route into which local arterials and collectors feed. In some smaller cities and towns, the state highway is often the only arterial connecting virtually all major destination points.

The provision of adequate pedestrian facilities along the state highways in these settings is a

critical component to incorporating pedestrians into the overall transportation network. Sidewalks for these main streets need to be designed the same as they would be for the urban centers of larger cities — able to support heavy pedestrian use. (Refer to specific design recommendations earlier in

this toolkit section, including the discussion on Sidewalks in Business Districts and Downtowns.) It is important to remember that there are differences between the small town main street environment and the larger city street environment, and applied design treatments should reflect community preferences.

Benefits and Disadvantages of One-Way Streets

Benefits for Pedestrians

- One-way streets in downtown areas or elsewhere, where practical, may be helpful to pedestrian travel because pedestrians have to watch traffic from only one direction when crossing.
- May also allow more space within the right-of-way in certain cases, creating more areas for pedestrians, parking, and other purposes.
- Can create smaller block patterns and allows reduced curve radii on corners where vehicular turning traffic doesn't occur, which equates to shorter crossing distances for pedestrians
- Improved signal timing because one-way streets can create consistent signal spacing (so pedestrians may walk at a continuous pace between intersections; but this can be a disadvantage in that it may speed traffic)

Disadvantages for Pedestrians

- Vehicles are likely to travel faster if the travel lanes are wide or there are multiple lanes
- May adversely affect transit operations and transfer opportunities

State Highways as Connectors Between Towns and Cities

Providing sidewalks and walkways along sections of urban highways that have many potential trip generators, such as schools, parks, scenic stops, and residential and commercial areas within proximity to one another, is recommended.

Maintenance

Clear smooth level surfaces are essential for pedestrians and particularly for people in wheelchairs, older adults, and young children. Sidewalks and walkways need to be cleared of snow and ice. Drainage systems should be kept in good working order to avoid accumulation of water over pedestrian walking areas.



Main street through small town.

Table 43

Construction and installation of utility lines and elements should be coordinated between the utility company and local agency with jurisdiction over the street system.

Interruptions to pedestrian travel need to be minimized and construction should avoid damage to pedestrian facilities. In some cases, it may be possible to improve conditions for pedestrians as part of an overall utility project. Such a project may create the opportunity to relocate a utility pole or box outside the pedestrian travel way.

Other Sources of Information

The following sources of information are recommended for design of sidewalks and walkways. Please see the Resource Guide included at the end of this guidebook for complete bibliography information.

A Guide to Land Use and Public Transportation, Volume II: Applying the Concepts, The Snohomish County Transportation Authority

A Guidebook for Student Pedestrian Safety, Final Report, KJS Associates Inc.

A Policy on Geometric Design of Highways and Streets, 1994, American Association of State Highway and Transportation Officials

A Working Approach to Accessibility in Public Rights of Way, Montana Department of Transportation

Accessible Sidewalks: A Design Manual, US Architectural and Transportation Barriers Compliance Board (The Access Board)

Accessibility Design for All, An Illustrated Handbook, 1995 Washington State

Regulations, Barbara L. Allan and Frank C. Moffett, AIA, PE

Accommodating the Pedestrian, Adapting Towns and Neighborhoods for Walking and Bicycling, Richard K. Untermann

Americans With Disabilities Act (ADA) Accessibility Guidelines for Buildings and Facilities; State and Local Government Facilities; Interim Final Rule, Federal Register, Part II, Architectural and Transportation Barriers Compliance Board

"Boulder Brings Back the Neighborhood Street," John Fernandez, *Planning*

City Comforts, How to Build An Urban Village, David Sucher

City of Issaquah Urban Trails Plan (Non-Motorized Transportation), City of Issaquah

City, Rediscovering the Center, William H. Whyte

Design and Safety of Pedestrian Facilities, A Proposed Recommended Practice of the Institute of Transportation Engineers, ITE Technical Council Committee 5A-5

Design Guidelines, Building/Sidewalk Relationships, Central Business District, City of Bellevue

Design Manual, 1020 Facilities for Nonmotorized Transportation, Washington State Department of Transportation

Effects of Site Design on Pedestrian Travel in Mixed-Use Medium Density Environments, Anne Vernez-Moudon, PhD

Engineering Design and Development Standards, Snohomish County Public Works

Florida Pedestrian Planning and Design Guidelines, University of North Carolina

Great Streets, Allan B. Jacobs

Handbook of Landscape Architectural Construction, Volume Two, Site Works, Maurice Nelischer

Handbook for Walkable Communities, Washington State Pedestrian Facilities Planning and Design Courses, Dan Burden and Michael Wallwork, PE

Livable Neighborhoods: Rethinking Residential Streets, American Public Works Association and the University of Wisconsin-Madison

Livable Streets, Donald Appleyard

Manual on Uniform Traffic Control Devices for Streets and Highways, 1988 Edition, US Department of Transportation

Pedestrian Malls, Streetscapes, and Urban Spaces, Harvey M. Rubenstein

Planning and Implementing Pedestrian Facilities in Suburban and Developing Rural Areas Research Report, S.A. Smith, K.S. Opiela, and L.L. Impett

Planning Design and Maintenance of Pedestrian Facilities, Goodell-Grivas, Inc.

Public Streets for Public Use, Anne Vernez Moudon

Reclaiming Our Streets, Traffic Solutions, Safer Streets, More Livable Neighborhoods, Community Action Plan To Calm Neighborhood Traffic, Reclaiming Our Streets Task Force

Redevelopment for Livable Communities, Washington State Energy Office, the Washington State Department of Transportation, the Department of Ecology, and the Energy Outreach Center

Residential Streets, American Society of Civil Engineers

Safe Walkways for Clark County, 1993-98 Walkway Construction Program, A Report to the Clark County Board of Commissioners

Sharing Our Sidewalks, Ensuring Access in Portland's Shopping and Commercial Districts, Metropolitan Human Rights Commission

Sidewalk and Curb Ramp Design, Governor's Committee on Concerns of the Handicapped *Streets for People, A Primer for Americans*, Bernard Rudofsky

The Car and the City, 24 Steps to Safe Streets and Healthy Communities, Alan Thein Durning

Time-Saver Standards for Landscape Architecture, Design and Construction Data, Charles W. Harris

Washington's Transportation Plan, State Bicycle Transportation and Pedestrian Walkways Plan, Washington State Department of Transportation

Intersections

This Toolkit Section Address:

- *Effects of Pedestrian Improvements on Vehicle Capacity*
- *Common Design Practices for Pedestrian Crossings at Intersections*
- *Minimizing the Crossing Distances at Intersections*
- *Minimizing Pedestrian/Motor Vehicle Conflicts*
- *Other Sources of Information*

This toolkit section addresses pedestrian facilities at intersections, as well as traffic regulating practices that can improve conditions for pedestrians at intersections.

Intersections are commonly designed with a focus towards motor vehicles than pedestrians. Even the best network of streets with well developed pedestrian facilities can suffer from low pedestrian use if there are inadequate facilities and obstacles at intersections.

Intersections can be made more pedestrian friendly by implementing designs that improve crossing conditions, reduce crossing distances and minimize conflicts between pedestrians and other intersection users.



Intersections are the most common location for pedestrian and motor vehicle collisions.



Effects of Pedestrian Improvements on Vehicle Capacity

The needs of pedestrians deserve equal consideration with the needs of motorists and other intersection users. Pedestrians have historically been treated as an afterthought in design of transportation facilities, but current practices encourage design approaches that improve conditions for pedestrians and fully integrate them into the transportation system.

The installation of improvements that reduce pedestrian crossing distances at intersections can affect vehicular capacity. Principal effects on capacity are caused by narrowing lanes and reducing curb radii. Other conditions that may affect intersection capacity are increased numbers of pedestrian crossings and bus stop relocations.

When determining the type and extent of improvements needed at intersections, the needs of all user groups should be considered and balanced. In some cases, it may be necessary to reduce motor vehicle capacity at intersections in order to achieve the best overall solution.

A traffic engineering analysis should be conducted as part of the design process to clearly determine needs and provide recommendations for channelization, turn lanes, acceleration and deceleration lanes, intersection configurations, illumination, and traffic control devices. Solutions should seek to provide maximum protection to pedestrians while still accommodating the operational needs of motor vehicles and other intersection users.

Common Design Practices for Pedestrian Crossings at Intersections

Intersection design requires consideration of all potential users of the facility, including pedestrians. Design approaches need to find ways to protect the access and safety of pedestrians, the most vulnerable user group at intersections while still adequately meeting the needs of motor vehicles.

Basic Principles of Intersection Design to Accommodate Pedestrians

- Intersections that function well for pedestrians are typically compact.
- Free-flowing motor vehicle movements are either eliminated or vehicles are forced to a significantly slower speed through the intersection.
- All legs of an intersection should be available for pedestrian use; closing a crosswalk doesn't necessarily prevent pedestrians from crossing in that direction. (Note that on some Tee intersections, it may not be desirable for pedestrians to cross in front of left turning vehicles.)
- Pedestrians need to be able to travel in a direct line across the intersection leg and the direction of travel needs to be clearly identified for all pedestrians, including those with sight impairments.
- Avoid increasing potential conflicts or the level of pedestrian exposure to motor vehicles (as would occur at multiple and skewed intersections).

Table 44

Sometimes meeting the needs of pedestrians may require a compromise in providing full service and capacity to motor vehicles at intersections, but more often, designers can balance these competing needs, resulting in adequate levels of operation for all users. Table 44 lists some basic principles of intersection design related to the needs of pedestrians.

Crosswalk Use

Whether marked or unmarked, crosswalks function as extensions of the approaching sidewalks, and when pedestrians are crossing in these areas, they have the right of way. RCW 46.61.235 (Rules of the Road) states:

“The operator of an approaching vehicle shall stop and remain stopped to allow a pedestrian to cross the roadway within an unmarked or marked crosswalk when the pedestrian is upon or within one lane of the half of the roadway upon which the vehicle is traveling or onto which it is turning.”

RCW 46.61.240 states:

“Every pedestrian crossing a roadway at any point other than within a marked crosswalk or within an unmarked crosswalk at an intersection, shall yield the right of way to all vehicles upon the roadway. (And) Between adjacent intersections at which traffic control signals are in operation, pedestrians shall not cross at any place except in a marked crosswalk.”

Given that crosswalk use is legally required, designing them to adequately meet the needs of all pedestrians is important. But design isn't the only consideration. If crossing



Typical Marked Crosswalk at Intersection

improvements are not functioning properly, there may be other problems, such as inadequate enforcement, poor visibility and obstructed sight lines, or level of service deficiencies.

Effectiveness of Crossing Improvements

Crossing improvements at intersections, such as crosswalk markings, signs, signals, refuge islands, and other elements, help to clearly delineate the pedestrian right-of-way to all users, including motorists, bicyclists, and pedestrians. The MUTCD lists five basic requirements for traffic control devices, which include intersection improvements, in order for them to function effectively.

Determining the Need for Crossing Improvements at Intersections

An important question often asked is, “How should the need for crossing improvements at intersections be determined?” The *Manual on Uniform Traffic Control Devices* (MUTCD) provides warrants for various crossing improvements, including signals, crosswalks, and other devices, and these warrants should be analyzed for all intersection projects. In addition to reviewing the MUTCD and other guidelines, good professional judgement and specific traffic engineering analyses on a case by case basis are recommended.

This toolkit generally describes current established processes for determining the need for improvements at intersections, such as marked crosswalks and signals.

Marked Versus Unmarked Crosswalks

A crosswalk is generally defined as the portion of the roadway designated for pedestrians to use in crossing the street. Marked crosswalks increase visibility of the pedestrian crossing area, define the space for crossing, and draw pedestrians to the appropriate crossing point. There is no legal difference between a marked or unmarked intersection crossing. Unmarked and marked crosswalks must be respected by drivers and pedestrians at intersections (see Figure 63 for an illustration of marked and unmarked crosswalks at an intersection). Mid-block crosswalks should always be marked.

The issue of marked versus unmarked crosswalks is often debated. Several studies have been completed over the past 25 years on the subject. Some of these studies have indicated that motorists are more likely to

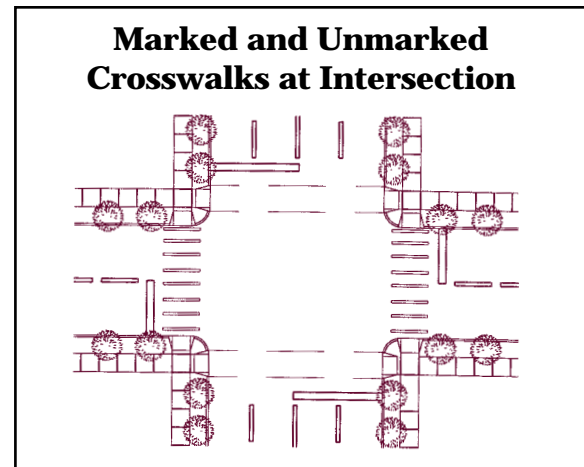

Figure 63

stop for pedestrians in marked crosswalks, rather than unmarked. Other studies have indicated that marked crosswalks may give pedestrians a false sense of security when crossing the street.

The 1972 publication of a five-year study of crosswalks in San Diego by B.F. Herms generated controversy by showing that pedestrian collision rates at marked crosswalks were twice that of unmarked crosswalks. Although Herms concluded that “it is appropriate to restate that marked crosswalks will continue to be a useful traffic control device,” a perception that emerged from this study was that crosswalks were an attractive nuisance. Some agencies concluded that crosswalks generate too much of a false sense of security among pedestrians and do not command the attention and respect of motorists. These agencies became less willing to install marked crosswalks.

A subsequent study by Bowman, Fruin, and Zeeger questioned Herms’ results. They called attention to the study’s failure to consider the possibility that known high-risk pedestrian groups, such as children and the elderly, were likely to prefer marked crosswalks to unmarked crosswalks. The 1972 study had indicated that these two

groups incurred most of the recorded injuries. The study's failure to collect usage data by age may have overlooked an important bias — that the most accident-prone pedestrians are likely to prefer marked crosswalks over unmarked crosswalks, if both options are available.

Further studies, most notably by Knoblauch, Tustin, Smith, and Pietrucha, applied more rigorous research and experimental techniques to crossings. They determined that marked crosswalks are safer and more preferred by both pedestrians and motorists than unmarked crosswalks under most conditions. The effectiveness and utility of marked crosswalks has been reaffirmed in surveys of both users and traffic officials in numerous studies (including Pfefer and Sorton, Zeeger and Zeeger, and E.A. Axler).

(Note the above summary of research findings was obtained from the *Pedestrian Crossing Study*, by Arctic Slope Consulting Group, Inc. for the City of Bellevue, March 1991.)

Marked crosswalks send an important message to motorists:

The crosswalk area is a defined pedestrian crossing space that should not be intruded upon.

For marked crosswalks to be continually effective, they must be located and designed in accordance with good judgement and accepted engineering practices. The MUTCD states that “*crosswalk markings should not be used indiscriminately,*” and this serves as a guiding premise to most local agencies.

Knoblauch et. al. developed a set of location guidelines based upon a comprehensive two-phase research and survey process. These guidelines state that as a general rule, crosswalks markings should be provided at:

- All signalized intersections with pedestrian signal heads
- All locations where a school crossing guard is normally stationed to assist children crossing the street
- All intersections and mid-block crossings satisfying minimum vehicular and pedestrian volume criteria in Figure 64 and the following basic criteria:
 - Speed limit equal to or less than 72 kph (45 mph)
 - Adequate stopping sight distance
 - For mid-block crosswalks, block length of at least 183 meters (600 feet)
 - Adequate crosswalk illumination
 - Minimal conflicting attention demands
- All other locations where there is a need to clarify the preferred crossing location because the proper location for crossing would otherwise be confusing

(Source: *Guidelines for the Installation of Crosswalk Markings*, Smith and Knoblauch, AAA Transportation Research Record 1141)

Some local jurisdictions are developing their own processes for determining the need for intersection crossing improvements that are suited to conditions within their community. For example, the City of Kirkland, a city known for its pedestrian friendly atmosphere, has established guidelines for installation of pedestrian crossing improvements. The first step in this process involves consideration of several basic conditions, listed in Table 45. At least one of these basic conditions must exist at the location being evaluated in order to further consider installation of crossing improvements. (Check with your local agency for project specific requirements.)

Guidelines for the Installation of Marked Crosswalks at Uncontrolled Intersections and Mid-Block Crossings

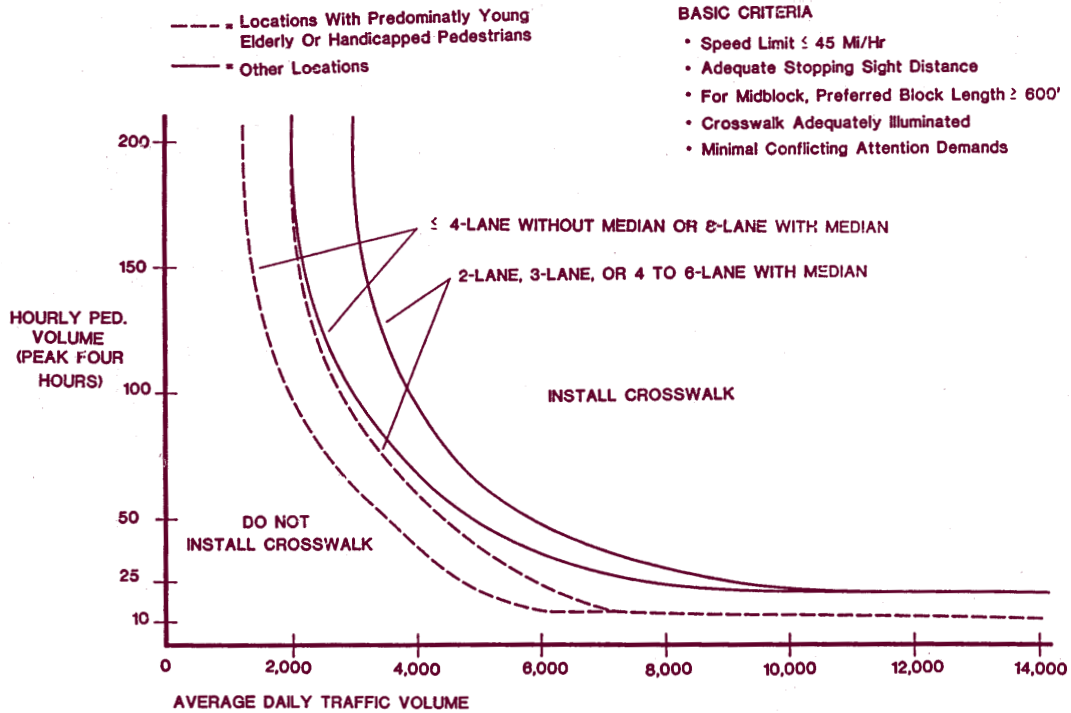

1. If using only the peak hour, threshold must be increased by 1.5
 2. For streets with median, use one -way (directional) ADT volume
- Other notes: Minimum striping is 6" parallel lines. Consider bolder markings and / or supplementary advance markings or signing at uncontrolled locations where speed limits exceed 35 mi/h.

Source: Smith and Knoblauch, AAA Transportation Research Record 1141 as reprinted in the ITE manual, Design and Safety of Pedestrian Facilities

Figure 64

Guidelines for Installation of Pedestrian Crossing Improvements (City of Kirkland Recommendation)

Basic Conditions to Be Considered

- Part of a school walking route
- Part of a route identified in the non-motorized plan
- Connects to significant retail
- Significant benefit to transit
- Distance to a better (higher level of protection or better sight distance or otherwise easier to cross) crossing point must be more than 300 feet
- A high majority of people served by the crossing have a more difficult than average time crossing the street
- A safety problem can be solved by improving the crosswalk

Source: City of Kirkland Transportation Department

Table 45

City of Bellevue Recommended Elements to Be Analyzed When Determining the Need for Marked Crosswalks

- Pedestrian demand
- Sight distance
- Traffic volumes (daily and peak hour)
- Vehicle gaps
- Vehicle speeds
- Existing and desirable lighting levels
- Channelization refuge (island) opportunity
- Special concerns — school walking routes, elderly needs, bus stops
- Collision history
- Distance to nearest crosswalk/intersection
- Number of lanes to be crossed
- Opportunity to concentrate pedestrian crossings at one location
- Citizen support
- Mid-block versus intersection
- Compliance with adopted standards (MUTCD) and other guidelines
- Traffic Patterns and Characteristics
- Driveway Locations/ Number
- Other Site Specific or Area-Wide Considerations

*How the above elements apply to crosswalk decisions varies depending on location. Planning studies may denote desirable pedestrian linkages; however, site specific engineering judgement/study should be conducted before implementation.
Source: City of Bellevue Transportation Department*

Table 46

The City of Bellevue has developed a list of considerations for determining whether or not to mark pedestrian crossings. These considerations are listed in Table 46.

Crosswalk Dimensions

The MUTCD outlines requirements for minimum crosswalk widths and markings. The MUTCD requires a minimum crosswalk width of 1.8 meters (6 feet). Wider crosswalks are often installed, particularly at crossings that receive high use. A width of 3.0 meters (10 feet) is commonly used for crosswalks. Crosswalks need to be at least the width of the approaching sidewalk. (*ITE Design and Safety of Pedestrian Facilities*). The approaching sidewalk or walkway and corner area at the intersection needs to be free of obstructions so that pedestrians can freely

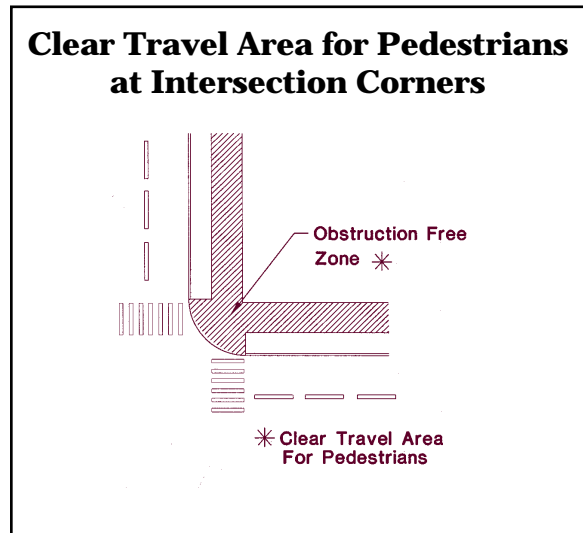

Figure 65

travel in either direction to cross the street (see Figure 65). Dimensional guidelines for crosswalks are summarized in Table 47.

Crosswalk Width and Marking Guidelines

	<i>Crosswalk Width</i>
MUTCD Minimum Requirement	6 ft.
Recommended Practice	10 ft. (or width of approaching sidewalks, if greater)

Table 47

Crosswalk Markings

Crosswalks can be marked using various methods. Crosswalk marking patterns vary and limited information is available about the effectiveness of different designs. There is no evidence to support that one design is better than another, but some designs provide better visibility than others. Local jurisdictions have developed their own preferences, so check in your area for the standard practice.

Generally, high visibility markings are suggested for locations where greater motorist information is considered beneficial and where pedestrians may not be expected to cross (such as mid-block locations), or where there are substantially higher pedestrian crossing volumes. Horizontal bars (two stripes perpendicular to vehicle traffic) are most often used at stop controlled intersections.

Diagonal markings or “zebra” stripes are more visible than horizontal bars, but diagonal markings tend to require replacement more often since they are subject to more friction from the wheels of motor vehicles. Piano bar markings are being used



Example of Ladder Bar Crosswalk

more frequently because they provide the benefit of good visibility and easier maintenance. With the piano bar pattern (and the ladder bar), the wheels of motor vehicles typically pass on either side of the markings, minimizing friction and deterioration. Table 48 illustrates several styles of crosswalk markings and lists advantages and disadvantages of each.

The minimum width of the horizontal bars recommended by the MUTCD is 15.2 centimeters (6 inches). Wider bars, 25 to 30 centimeters (10 to 12 inches), are recommended by the ITE, particularly at crosswalks that receive high use or deserve special attention.

Stop bars are typically placed at intersections where motorists are required to stop to

Advantages and Disadvantages of Crosswalk Marking Patterns

	<i>Marking Pattern</i>	<i>Advantages</i>	<i>Disadvantages</i>
	Horizontal Bars	Common practice at stop controlled intersections, less expensive, easy to install and maintain	Not as visible as some other marking types; bars tend to wear faster than other types; not appropriate for mid-block locations
	Zebra	Highly visible	More maintenance required since wheel friction rubs off diagonal stripes; surface can be slippery
	Ladder Bar	Highly visible	Wider stripes rub off with wheel friction, but can be placed to minimize this effect; surface can be slippery
	Piano	Highly visible and becoming more commonly used; easy to maintain since stripes can be placed outside the wheel friction areas	
			
			
	Dashed (European)	Captures attention because it is not a commonly used pattern	May not define space as well as some of the other choices
	Solid	Visible (but may not be as eye catching as other patterns); not commonly used	Expensive; more difficult to install and maintain; surface can be slippery
			

Table 48



prevent overhang into crosswalk areas. Stop lines are normally 0.3 to 0.6-meter (12 to 24-inch) wide white stripes that extend across all approach lanes. Stop bars need to be located at least 1.2 meters (4 feet) in advance of the crosswalk, and can either be parallel to the crosswalk or angled or staggered in each lane to increase visibility. Strategically locating and skewing stop bars improves visibility of pedestrians, as well as operations for right-turn-on-red vehicles and for vehicles turning left from the cross street.

Rumble strips with raised pavement markers or buttons are sometimes placed in advance of crosswalks in rows, which create a “rumbling” effect alerting approaching drivers of the upcoming crosswalk. Use of these types of markers is not generally recommended unless they can be placed far enough in advance of the crosswalk to be an effective warning device (at the same location as the crosswalk advance warning sign). Raised pavement markers are not allowed to be placed near the right edge line because they are an obstacle to bicycle travel (see discussion in Toolkit 5 — Sidewalks and Walkways). If raised pavement markers are used, they must be placed outside the required clearance area of bike lanes. The use of raised pavement markers is required to be analyzed on a case-by-case basis. They should only be installed after a traffic engineering study determines they are needed.

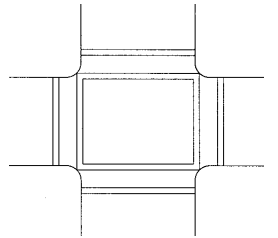
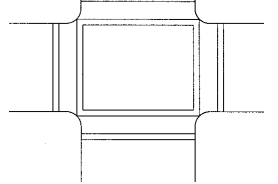
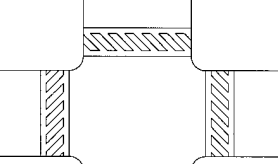
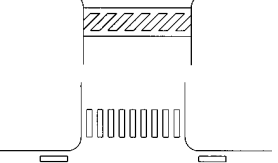
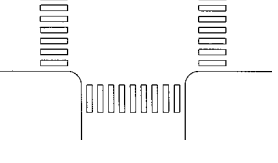
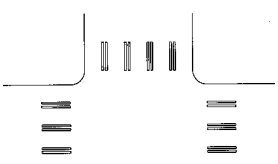
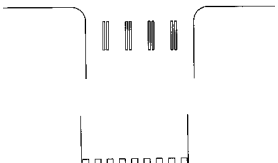
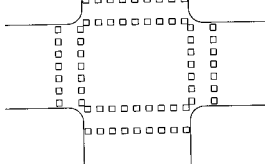
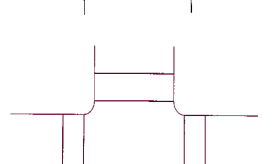
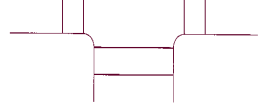
Markings should be monitored regularly and maintained in good condition. They should also be removed when no longer needed. Painted markings are less expensive than plastic markings, but the plastic markers have a longer life. Check with your local agency for crosswalk and pavement marking requirements. Also, for more specific design details related to pavement striping and marking techniques, refer to other sources,

such as the MUTCD and the WSDOT *Design Manual*.

Curb Ramps

Curb ramps are often considered to be the most important elements of an accessible pedestrian environment. Curb ramps provide accessibility at the grade transition between intersection corners and lower street grades. They facilitate crossing for wheelchair users, people pushing strollers, bicyclists and others. If properly located, they can also help to direct pedestrians, including sight-impaired people in the direction of the crosswalk if they are properly located. Toolkit 2 — Accessibility, discusses placement and design of curb ramps.

Lighting

The street lighting level provided at intersections may need to be supplemented with additional lighting in areas of heavy pedestrian traffic during early morning, late evening, or nighttime hours. Refer to the standards and design guidelines of the Illuminating Engineering Society of North America.

Location of Drainage Inlets and Grates

Drainage grates should be located away from crosswalks and curb ramps and outside the route of pedestrian travel. It is preferable to locate drainage inlets on the upstream site of the crosswalk to avoid excessive drainage flows across the crossing area. Roads and gutters should be graded to direct drainage away from intersection corners and walking areas.

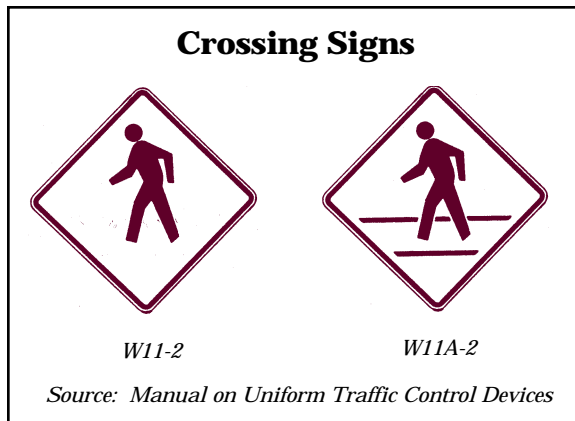

Figure 66

Pedestrian Related Signs

It may be necessary to provide signs at or near an intersection. Regulatory signs are generally rectangular shaped signs that identify special conditions and regulate motorists and pedestrians. Warning signs are diamond shaped, with black and yellow colors and are used to identify upcoming conditions that may not be expected.

Pedestrian related warning signs include the standard pedestrian crossing signs used at locations to identify upcoming crossings (refer to Figure 66). The pedestrian warning sign with the pedestrian symbol and no crosswalk should be used in advance of crossings or areas of high pedestrian use. Refer to MUTCD for distance requirements for advance signing. The warning sign with the pedestrian symbol in the crosswalk should only be used **at** the crosswalk location.

Minimizing the Crossing Distances at Intersections

Minimizing the crossing distance at intersections enables pedestrians to cross the street more safely and comfortably. Techniques that reduce pedestrian crossing

distance and time also provide the added benefit of improved timing at signalized intersections (without sacrificing the need for an adequate protection phase for the pedestrian). Several design techniques for reducing crossing distances at intersections are described in the following text.

Curb Return Radius

Historically, design of curb return radii at intersections has not typically considered the needs of pedestrians. With new design and retrofit design of intersections, it is important to consider the needs of all users of the intersection and to balance these needs to provide the safest operating conditions for all.

The use of shorter curb return radii at intersections is beneficial for pedestrians because it reduces the crossing distance of the intersection. Reduced radii also help to slow vehicles as they travel through the intersection, enabling drivers to respond more quickly to signal changes and crossing pedestrians.

The need for shorter pedestrian crossing distances and reduced vehicle speeds needs to be balanced with the need to provide adequate curb radius lengths to accommodate the types of vehicles that turn at the intersection. A radius that is too small can cause large vehicles and buses to jump the curb, causing deterioration of the curb and intrusion into the waiting and standing space for pedestrians.

It may not always be practical to reduce the curb return radii at all intersections used by pedestrians, particularly at existing intersections. But at intersections where there is heavy pedestrian crossing activity and limited truck and bus turning

movements, it may be desirable to shorten the radius by adding curb extensions or bulb-outs. It may also be desirable to analyze transportation routes in the area and to reroute trucks onto streets that receive less pedestrian use. This would enable streets more heavily used by pedestrians to be retrofitted with shortened curb radii without significantly affecting the overall operational needs of large trucks and buses in the area.

If truck and bus turning activity occurs at a minimal level, AASHTO standards permit 5.1 to 7.6 meters (15 to 25 feet) curb radii on minor streets. On major streets, AASHTO allows a minimum turning radius of 9.1 meter (30 feet) if the occasional truck can turn with some minimal encroachment. These standards may vary at the local level. In some cases local jurisdictions may encourage the use of shorter than standard curb radii at intersections where there is likely to be frequent pedestrian crossing activity.

Curb return radii larger than 9.1 meters (30 feet) generally are not desirable at urban intersections where there are high numbers of pedestrians crossing. It may be necessary to provide a 9.1-meter (30-foot) radius or larger at urban intersections where large trucks and buses turn frequently.

Figure 68 illustrates how reduced curb radius at an intersection shortens the pedestrian crossing distance by comparing the crossing distance between two 4.6-meter (15-foot) radius corners with the crossing distance between two 9.1-meter (30-foot) radius corners at an intersection.

In certain situations, very short curb radii of 1.5 meters (5 feet) can be used on one-way streets at the corner where no turning movements are possible. Figure 67 illustrates how the use of one-way street patterns can

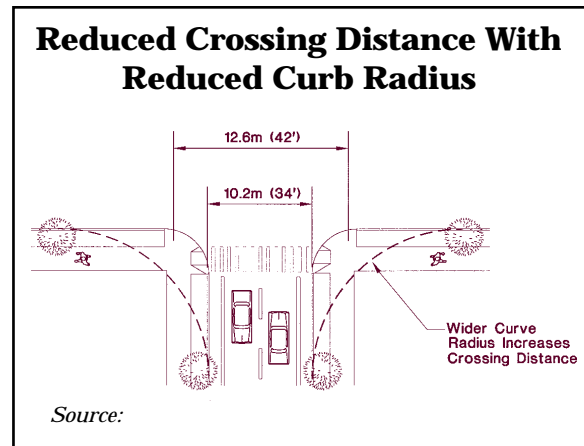

Figure 67

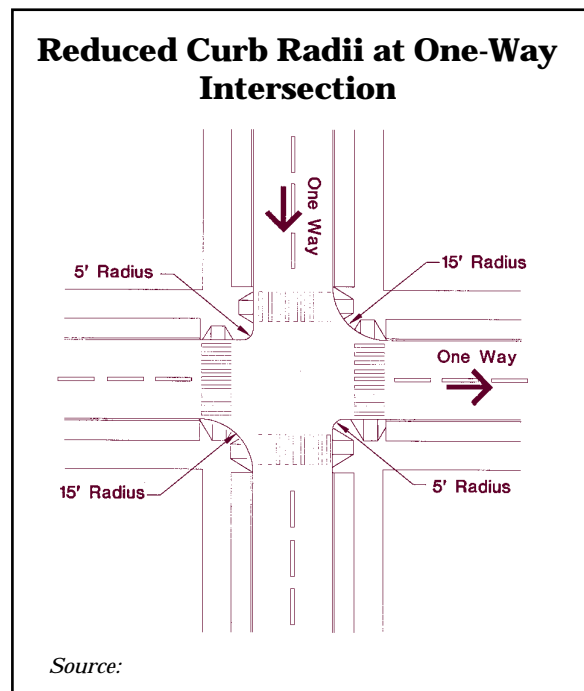

Figure 68

enable reduced curb radii at the non-turning corners of the intersection. For more discussion on one-way streets, refer to Toolkit 5 — Sidewalks and Walkways.

Table 49 summarizes the benefits and disadvantages related to shortening curb radii at intersections.

Benefits and Disadvantages of Shortening Curb Radii

Benefits

- Reduces crossing distances for pedestrians
- Slows vehicular movement through intersection
- Heightens awareness of pedestrians
- Improves signal timing because the time for the pedestrian crossing phase can be reduced

Disadvantages

- May not be feasible at intersections where buses and large trucks turn frequently
- If radii are too small, larger vehicles may either have to swing into opposing traffic or drive over the curbing at the corner causing deterioration and intruding into pedestrian waiting space
- Decreases vehicular capacity at intersection

Table 49

Right-Turn Channelization (Slip) Lane with Refuge Island

At wide intersections, there is often a triangular space between the through-lane and the right-turn lane (also called a “slip” lane) unused by motor vehicles. Placing a raised island in this area provides pedestrians a refuge area when crossing. This may be an appropriate solution where curb return radii of larger than 9.1 meters (30 feet) are unavoidable. This type of design is only appropriate for use when it fully addresses the needs of pedestrians. If designed properly, these devices can help to balance the needs of large vehicles and pedestrians at busy intersections.

At locations with extremely high numbers of right turning movements, slip lanes should be protected with a signal to provide pedestrians opportunities to cross.

Also, refuge islands should be designed with an elongated tail (see Figure 69), which stretches out the turning movement and provides vehicles more space to slow and

observe pedestrians crossing the lane. (This elongated design is recommended by the *Handbook for Walkable Communities* as a method to make right-turn slip lanes safer for pedestrians. It has not yet been incorporated into the AASHTO Green Book.)

The refuge islands should be raised to provide a vertical barrier and added protection between vehicles and pedestrians. Refuge islands need to provide curb cuts, or cut-throughs if space is limited, for accessible passage. AASHTO requires that curbed islands generally be no smaller than 5 square meters (54 square feet), but preferably a minimum of 9 square meters, (97 square feet). Triangular refuge islands should be a minimum of 6.1 to 7.6 meters (20 to 25 feet) long and not less than 1 meter (3.3 feet) wide in the crossing region and 0.5 meters (1.6 feet) wide in the tail region. A wider area is needed to provide curb ramps and a level area between the curb ramps in the crossing region.

Pedestrian push buttons may be needed when the signal timing doesn't allow all pedestrians to cross the street on one crossing phase.

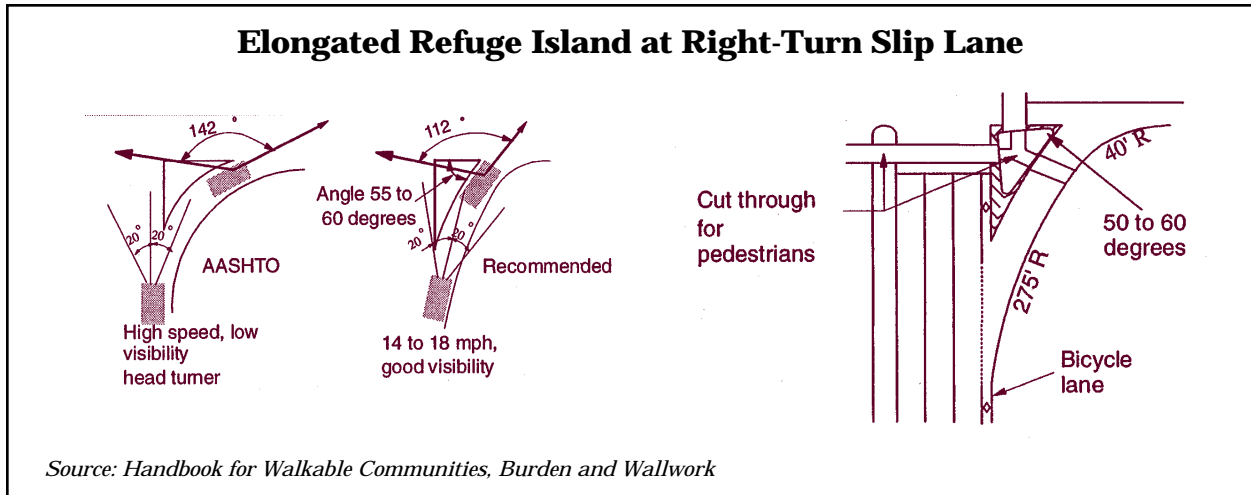

Figure 69

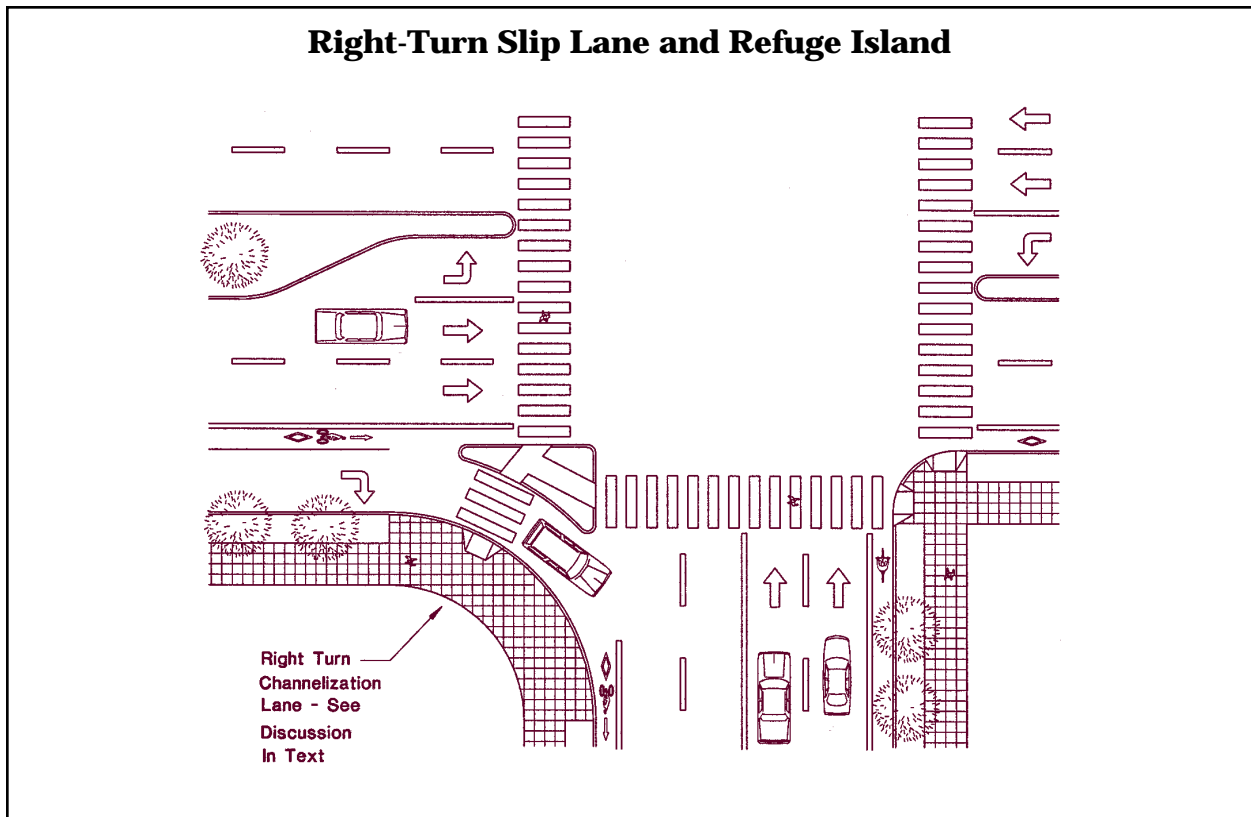

Figure 70

These areas should be clear of obstacles such as utility facilities and landscaping above 0.6 meters (2 feet). The crossing point may be marked with a highly visible crosswalk design and a stop bar. Directional barriers or

devices (such as bollards, signs, or other elements) may be necessary to keep pedestrians from stepping off the curb in areas other than the crosswalk.



Right-Turn Slip Lane With Refuge Island

Refer to Figure 70 for an example of a right-turn channelization lane and refuge island at a larger curb radius intersection.

Medians and Center Refuge Islands

Medians and center refuge islands at intersections provide waiting areas for pedestrians and eliminate the need for pedestrian to cross both directions of traffic all at once. Medians and center refuge islands can be created at intersections or mid-block to help define the pedestrian walking space and provide protection and refuge from motor vehicles.

Refuge islands are typically shorter than medians, but either can be used at intersections. Medians and center refuge islands provide the benefit of turning one two-way street into two one-way streets from the perspective of the pedestrian. Pedestrians only have to cross one direction of traffic at a time and can wait and rest in between if necessary. Medians and refuge islands are generally most necessary where the length of crossing exceeds 18.3 meters (60 feet), depending on the signal timing, but can be used at intersections with shorter crossing distances where a need has been determined.

Locations Where Refuge Islands are Most Beneficial

- Wide, two-way streets (four lanes or more with high traffic volumes, high travel speeds, and large pedestrian volumes)
- Wide streets where children, people with disabilities, or elderly people cross regularly
- Wide two-way intersections with high traffic volumes and significant numbers of crossing pedestrians
- Low volume side street traffic demands with insufficient time to cross
- Minor access/local residential streets where they function both as traffic calming devices and street crossing aids

Table 50

Table 50 lists typical conditions where refuge islands can provide the greatest benefit.

Medians and center refuge islands need to be large enough to provide refuge for several pedestrians waiting at once. They generally should be a minimum of 1.8 m (6 feet) wide and preferably 2.4 m (8 feet) wide or more where possible. These areas also need to be accessible, with either curb ramps or at-grade cuts. Cut-throughs are generally easier to construct and easier for pedestrians to negotiate than curb ramps, particularly on smaller islands.

Refuge islands should be raised to provide a vertical barrier between pedestrians and motor vehicles. Sometimes a small nose can be placed in front of the crosswalk to provide additional protection to pedestrians waiting

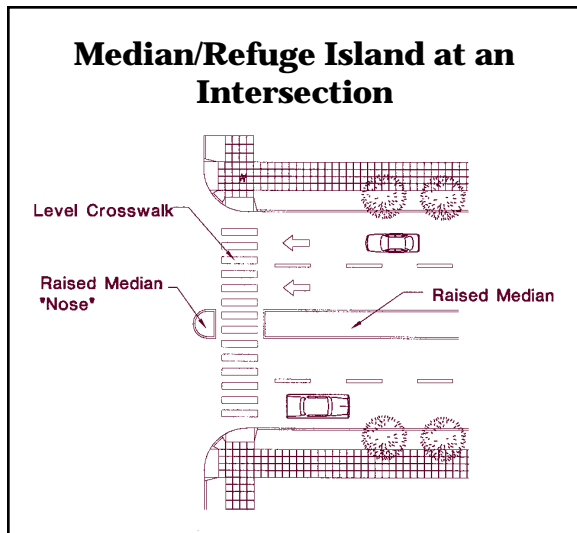

Figure 71

at the median and refuge island. The use of medians and refuge islands at intersections also help to provide added protection during left-turning movements. Pedestrian push buttons should be mounted in the islands to provide pedestrians control over the signal phases from their refuge position. Push button posts and other poles need to be located out of the pedestrian travel way, but not inconveniently far from reach.

Figure 71 illustrates a median/refuge island at an intersection. For more discussion on medians and refuge islands, refer to Toolkit 7 — Crossings.

Curb Bulb-Outs and Extensions

In addition to reducing crossing distances, curb bulb-outs and extensions make pedestrians more visible to motorists at intersections. Curb bulb-outs and extensions at intersections and mid-block crossings may help to slow traffic by narrowing the street.

Curb extensions and bulb-outs work particularly well on urban streets where there is limited turning traffic by buses and large

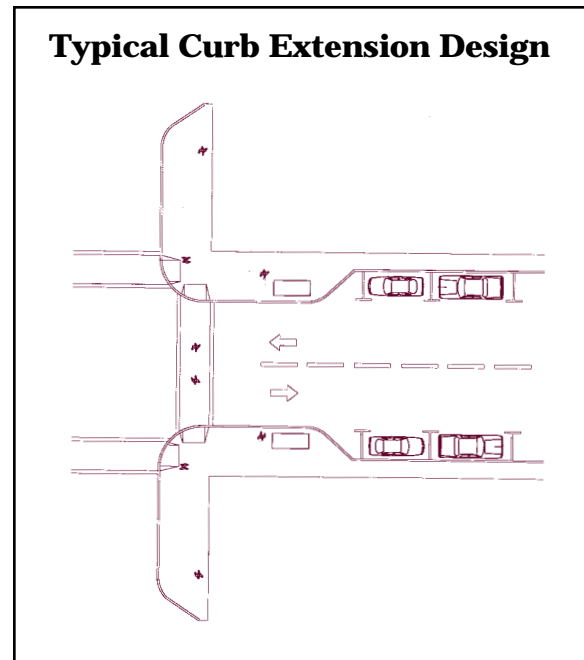

Figure 72

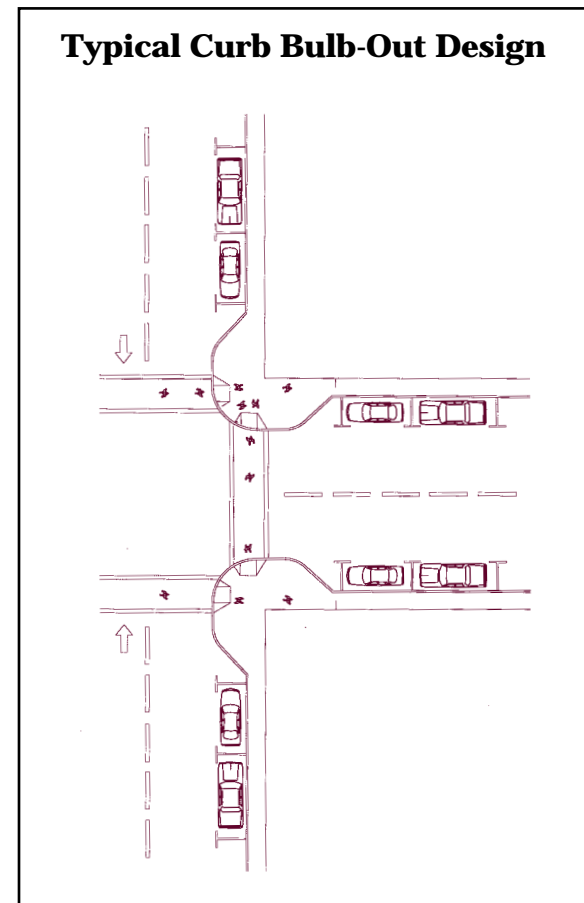

Figure 73

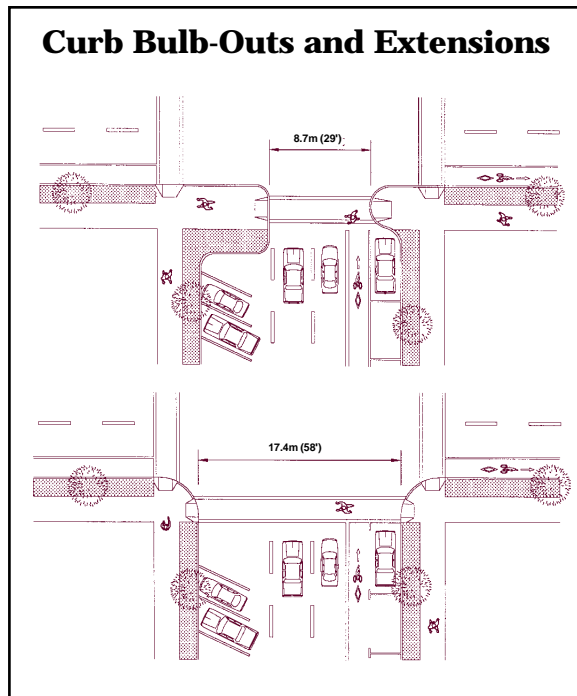

Figure 74

vehicles or that accommodate one-way traffic, and on minor streets in residential areas. They are also effective in delineating on-street parking zones. Other types of traffic calming techniques are described in Toolkit 8 — Traffic Calming. Figure 72 illustrates a typical curb extension design, and Figure 73 illustrates curb bulb-outs. Figure 74 illustrates how crossing distance is reduced through the use of curb extensions.

Avoiding or Reconfiguring Multiple and Skewed Intersections

Multiple intersections are intersections with more than four legs or vehicle approaches. Skewed intersections are created when intersections join at awkward angles.

Minimizing Pedestrian/Motor Vehicle Conflicts

Visibility and Sight Distance

Providing good sight distance at intersections is commonly overlooked. Facilities such as signs, utility poles, bus stops, benches, and other elements are often added after design and construction of an intersection, inhibiting driver and pedestrian visibility. These elements should not be located in areas that interfere with sight distances. Figure 75 illustrates the area at an intersection that typically should be kept clear of obstructions. Refer to WSDOT or local agency design standards for the adopted method to calculate sight distance triangles at intersections and driveways.

Elements that obstruct the downward views of high-seat position drivers (such as bus and truck drivers) should also be avoided at intersections (within the sight distance triangle area), including trees, signs, hanging banners, or other elements.

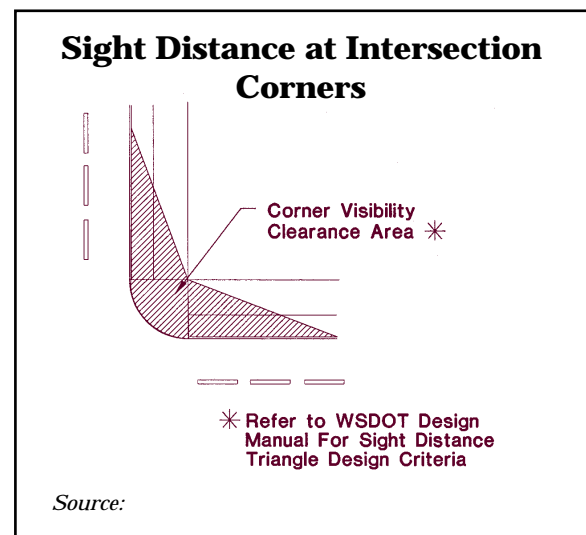

Figure 75

On-Street Parking Restrictions

On-street parking near pedestrian crossing points can interfere with visibility. When cars are parked too close to crossing points, they may block the line of sight between the driver and the pedestrian stepping off the curb to cross.

RCW 46.61.570 prohibits parking within 6.1 meters (20 feet) of a crosswalk and within 9.1 meters (30 feet) of a stop sign, signal, or flashing beacon. The *ITE Design and Safety of Pedestrian Facilities* recommends that parking be restricted within 15.2 meters (50 feet) of all intersection crossings where the speed of travel on the street is 56 to 72 kph (35 to 45 mph), and be restricted within 30.5 meters (100 feet) at intersections on streets where the speed of travel is above 72 kph (45 mph) and at mid-block crossings.

This guidebook recommends that professional judgement be applied when considering the appropriate distance for parking setbacks from specific pedestrian crossing points. In certain situations, it may be appropriate to require a greater setback distance from

crossing points 15.2 to 30.5 meters (50 to 100 feet), such as:

- near schools where many children are crossing;
- at intersections or crossings that are not signalized;
- on roadways where travel speeds exceed 35 mph; and
- on roadways with elements that affect sight and stopping distance (curves, bridges, vegetation, etc.)

In some situations, a setback less than 50 feet may be appropriate, such as in central business districts, downtowns, or other areas where travel speeds are typically slower (between 20 and 30 mph), and at signalized intersections or crossings. Curb extensions (bulb-outs) at intersections and crossing points provide space for pedestrians to stand in better view of approaching vehicles, and on-street parking can be placed closer to the crossing point without affecting visibility of pedestrians.

Uncontrolled intersections and mid-block crossings are of particular concern where inadequate sight distance exists, because

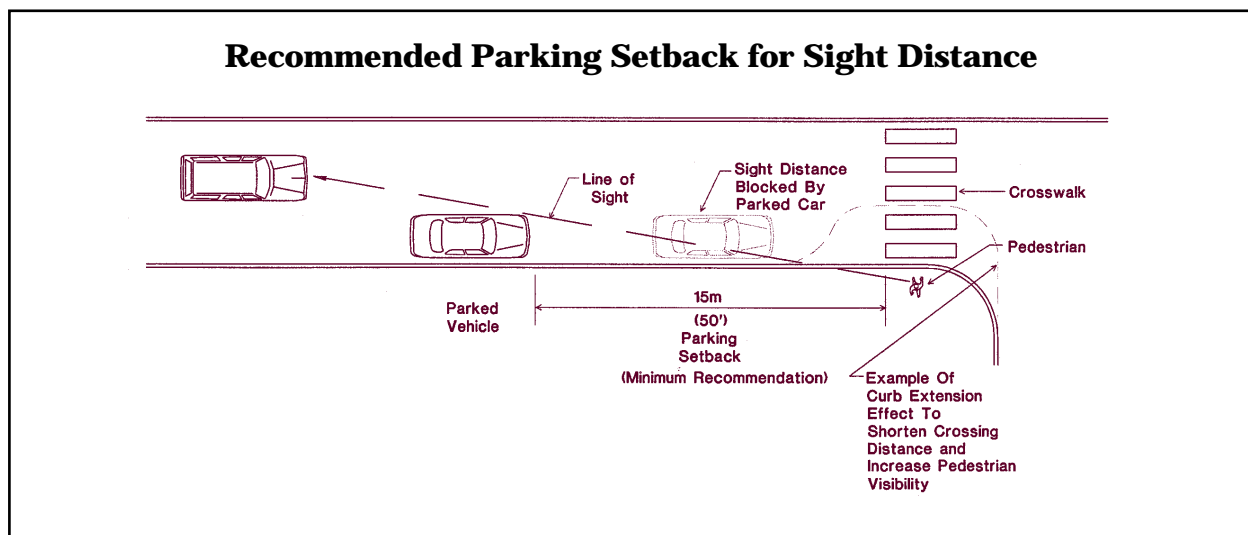

Figure 76

there is no control (stop sign or signal) over the movements of vehicles and pedestrians. Additional considerations related to on-street parking are discussed in Toolkit 5 — Sidewalks and Walkways.

Traffic Regulation and Access Management

Traffic regulation and access management practices can help reduce potential conflicts between pedestrians and motor vehicles at intersections. For more information about access management, refer to Toolkit 5 — Sidewalks and Walkways and Toolkit 10 — Site Design. Traffic control and regulation devices are discussed in more detail in the following text.

Signalization

The WSDOT *Design Manual* states that the needs of all pedestrians shall be considered at all traffic signal installations where pedestrian activity might be expected.

Pedestrian Indications (Signal Heads and Symbols) and Exclusive Pedestrian Phase

Pedestrian signal indications include walk/don't walk or the symbolic man/hand symbol used in conjunction with traffic signals. The MUTCD provides a list of warrants for pedestrian indications. Traffic signal symbols used to direct motorists may not provide the correct message to pedestrians. For this reason, it is strongly suggested that traffic engineers fully consider the need for pedestrian indications at *all* signalized crossings that have the potential to be used by pedestrians.

Pedestrian indications are typically provided when vehicular movement is controlled by

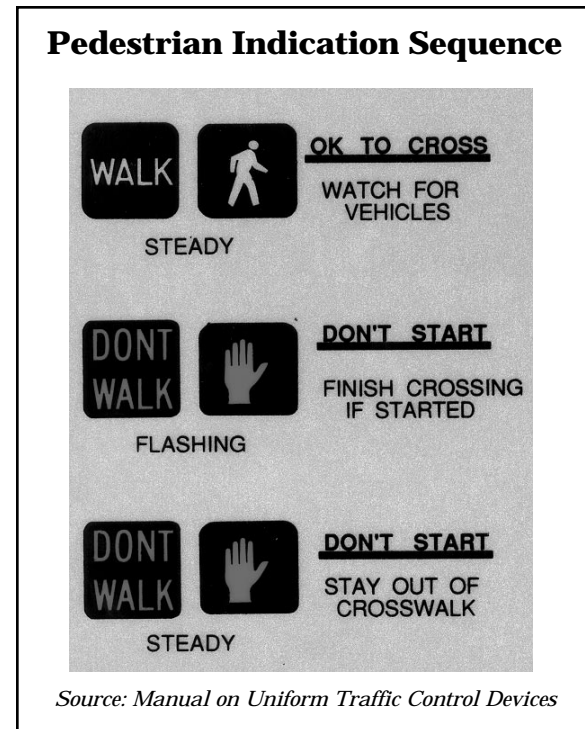

Figure 77

actuated equipment and when pedestrian actuators have been installed.

Pedestrian indications and signal heads need to be installed in clearly visible locations from the crosswalk approaches. Audible devices are being used in some areas. This type of indication is particularly helpful to sight impaired pedestrians.

Research has documented that many pedestrians do not understand the meaning of pedestrian signal indications, particularly the flashing "DON'T WALK" symbol.

Figure 77 illustrates the pedestrian indication symbols commonly used in Washington and throughout the United States, as well as the action to be taken during each phase of the signal indication.



Where there is heavy pedestrian crossing activity (near a transit center or college campus, for example), an exclusive pedestrian signal phase may be provided to allow pedestrians to cross in one or more directions. A “pedestrian scramble,” where pedestrians are allowed to cross at all directions (including diagonal) within a well defined intersection area is an example of an exclusive phase application. During this exclusive pedestrian phase, no vehicular movement typically takes place.

Pedestrian Actuated Signals

Pedestrian actuated signals may be warranted at intersections (and mid-block locations) where there are inadequate gaps in the stream of traffic to provide frequent enough opportunities for pedestrians to cross. Install pedestrian actuated signals only at locations where they are warranted in accordance with the MUTCD guidelines. Adequate sight distance is necessary at these locations, and warning signs should be installed in advance of the signal.

Some examples of locations where pedestrian actuated signals may be appropriate include:

- Intersection crossings where the level of pedestrian activity may be relatively low, but the traffic volume and speed of vehicles is high, or gaps in traffic are not adequate to allow pedestrians to cross
- Mid-block crossings on streets where pedestrian activity is high and the volumes and speeds of vehicular traffic are also high
- Heavily used mid-block bus stops (provide increased responsiveness of the actuation during times of peak hour pedestrian access to the bus stop)

Measures to Improve the Effectiveness of Push Buttons

- Maintain push buttons as necessary to ensure they are functioning
- Make push buttons responsive to pedestrians
- Provide signing to show which street crossing push button controls
- Sign operating times for push buttons designed to operate only during certain times

Table 51

The MUTCD provides signal warrant guidelines related to pedestrian actuated signals. Local jurisdictions may use other criteria to determine the need for these signals. Toolkit 3 — Children and School Zones and Toolkit 7 — Crossings also discuss the use of pedestrian actuated signals.

Push Buttons (Actuators/Detectors)

Pedestrian push buttons and detection devices should be conveniently located near the end of crosswalks and in easy to reach positions. They should be located no more than 1.5 meters (5 feet) from the pedestrian travel way and face toward pedestrians. It is recommended that signs be mounted on the push-button poles to identify which button to cross for each crossing direction. The purpose and use of push buttons should be clearly identified, and they should clarify which crosswalk they are linked to.

In addition to being located at intersections, pedestrian actuators may also be located in intersection or mid-block refuge areas, where pedestrians may be caught crossing during the end of the walk cycle. In some areas with heavy pedestrian volumes, or where signal

cycles are particularly long, it may help to place additional actuators in advance of the intersection to decrease pedestrian waiting time. Research shows that when pedestrians have to wait on average over 30 seconds, they have a tendency to not wait. Pedestrian use should be considered when selecting cycle lengths. Table 51 lists recommended measures to improve the effectiveness of push buttons.

The use of motion detectors, infrared, or video devices to automatically change the signal phase when pedestrians approach the crossing is experimental. Also, special signals are being tested that allow vehicles to proceed

in an intersection during the pedestrian cycle when there are no pedestrians present (see discussion on PUFFINs and PELICANs in Toolkit Section 7 — Crossings.)

Refer to the MUTCD and the WSDOT *Design Manual* for additional information. Figure 95 illustrates the WSDOT *Design Manual* details for pedestrian push buttons, including the recommended mounting height of 1.1 meters (3.5 feet) from ground level.

Signal Timing

Signals are often installed with a focus toward accommodating smooth motor vehicle flows rather than accommodating the needs of

Crossing Distances, Speeds, and Time

<i>Crossing Distance</i>	<i>Average Pedestrian Crossing Time at 1.2 m/second (4 ft/second)</i>	<i>Older Adult Crossing Time at 0.9 m/second (3 ft/second)</i>	<i>Mobility Impaired Pedestrian Crossing Time at 0.8 m/second (2.5 ft/second)</i>
7.3 m (24 ft) 2 lanes*	6 seconds	8 seconds	9.6 seconds
10.4 m (34 ft) 2 lanes with bike lanes	8.5 seconds	11.3 seconds	13.6 seconds
14.0 m (46 ft) 3 lanes with bike lanes	11.5 seconds	15.3 seconds	18.4 seconds
17.7 m (58 ft) 4 lanes with bike lanes	14.4 seconds	19.3 seconds	23.2 seconds
21.3 m (70 ft) 5 lanes with bike lanes	17.5 seconds	23.3 seconds	28 seconds

* Assumes 3.7-meter (12-foot) vehicular lane width and 1.5-meter (5-foot) bike lane width.
Source: Adapted from walking speed estimates

Table 52



pedestrians. Traffic signals are usually timed for vehicle speeds, causing pedestrians to have to stop at nearly every intersection.

Signals with excessively long waits may cause pedestrians to cross against the signal, increasing the potential for pedestrian/motor vehicle conflicts. Research indicates that many pedestrians stop watching for the light to change, and instead start looking for gaps to cross streets when their delay exceeds 30 seconds. Installation of pedestrian actuation devices can help with this problem.

Signals that do not provide enough time for pedestrians to cross are also a major concern. The walking speed normally used for calculating pedestrian walking time is 1.2 meters (4 feet) per second, but this may not provide adequate crossing time for all pedestrians.

Studies have indicated that up to 30 percent of the population do not normally walk as quickly as 1.2 meters (4 feet) per second. Recent research by Knoblauch, Pietrucha, and Nitzburg determined that for design purposes, values of 0.91 meters (3 feet) per second are appropriate for older pedestrians. Other studies have indicated that some pedestrians with mobility impairments travel at 0.8 meters (2.5 feet) per second or slower. Table 52 depicts the length of time necessary to cross various distances at these speeds. This table is provided to compare the differences in crossing time that can occur with different pedestrian groups.

Set or adjust signal timing to accommodate a greater cross-section of the population. Several sources, including the ITE manual *Design and Safety of Pedestrian Facilities*, are recommending the use of the 0.9 meters (3 feet) per second travel speed for signal timing. When there is a known presence of slower

pedestrians (including elderly and people with mobility impairments) who regularly use a crossing (near a retirement home or hospital), the possibility of extending signal crossing time in these areas should be considered.

WALK Signal Timing

At some intersections, the 4 to 7 second “start-up” time walk interval recommended by the MUTCD may present a dilemma to pedestrians who see the “DON’T WALK” display before they are more than one or two lanes across the street, especially since as discussed earlier, many pedestrians do not always understand that the flashing “DON’T WALK” symbol doesn’t mean to stop walking. It may be desirable to provide a longer “WALK” interval at some locations, like at particularly wide intersections, or in areas where there is clearly confusion among crossing pedestrians.

Turning Movements

Regulating turning movements at intersections can improve conditions for pedestrians. According to the ITE, 37 percent of all pedestrian/motor vehicle collisions at signalized intersections involve left- or right-turning vehicles. Table 53 lists potential solutions to minimize pedestrian/motor vehicle conflicts involving left- or right-turning vehicles.

Right-turn channelization should be used only where warranted by traffic study. The addition of a right-turn lane increases crossing distances for pedestrians and allows vehicles to travel more freely when turning right through the intersection. This may cause inattentive drivers to not notice pedestrians on the right. Elimination of free-right-turn-on-red movements may be an appropriate solution at certain intersections

Reducing Turning Conflicts

- Design compact intersections with small turning radii that force slower speeds
- Prohibit right-turn-on-red
- When right-turn slip-lanes are used, place crosswalks as far upstream as possible and provide highly visible markings
- Use a separate left—turn phase in conjunction with a WALK/DON'T WALK signal; or restrict left turns at downtown intersections and on commercial streets, during certain hours when there are higher concentrations of pedestrians at intersections
- Shorten crossing distance and exposure time with curb extensions or bulb-outs
- Provide medians and refuge islands
- Place signs to remind motorists of their duty to yield to pedestrians while turning left or right
- Provide well-illuminated crossings
- Improve marking and visibility of crosswalks

Sources: Design and Safety of Pedestrian Facilities,

Table 53

where there is a high level of anticipated conflict with motor vehicles.

Dual Turning Movements

It is strongly recommended that dual turning movements be avoided at intersections used by pedestrians. Warrants for dual turn lanes should be used to ensure that they are

provided only if necessary. If dual turn lanes are installed, a separate pedestrian crossing phase in a signal or prohibiting crossing may be necessary.

Dual turning movement lanes are particularly difficult for pedestrians. Dual turn lanes increase the level of unpredictable movements at intersections. Visibility is impaired when multiple vehicles are turning at the same time. In addition, dual turning lanes may not be well utilized by motor vehicles. One lane may be favored and as a result, motor vehicle speeds may be different in each lane. Drivers are often not able to see beyond the car in front or to the side of them to determine if there is a pedestrian crossing the street.

For right-turn channelization lanes, consider the possibility of adding a controlled slip lane with a refuge island, which provides added protection for crossing pedestrians if designed properly (see discussion earlier in this section).

Interchanges and Expressway Ramps

Expressways and freeways often present barriers to pedestrian circulation.

Pedestrians crossing exit and entrance ramps often conflict with drivers traveling at high speeds. Drivers' attention is often focused on other traffic and not on pedestrians.

Several design treatments can be applied to improve pedestrian crossing at interchanges.

- Provide as short a crossing distance as possible and at a right angle to the ramp
- The crossing point should be located at either the terminus or the beginning of the ramp, where the vehicle is just entering or has slowed from its exit



- Entrance and exit ramps that encourage free-flowing motor vehicle movements are not desirable in areas where there is heavy pedestrian crossing traffic. Slowing or stopping of motor vehicles in these areas is strongly recommended.
- Interchanges and access ramps connecting to local streets at right angles are easiest for pedestrians to cross, because crossing distances are reduced and visibility is enhanced. These intersections should be designed in accordance with accepted practices. Controls such as stop signs and signals provide pedestrians opportunities to cross.
- With ramps that merge into the local street system at expressway access points, channelization islands can be installed to provide refuge area for crossing pedestrians. This reduces crossing distance for pedestrians, which helps to improve signal timing. The shorter the ramp crossing distance, the better.
- Pedestrian crossings at controlled access ramps need to be clearly marked and identifiable to approaching motorists.
- Good sight distance and visibility at ramp terminals is an important necessity.
- Grade separation may be necessary (see discussion later in this section).

Grade Separation

Grade separation may be necessary at crossings where extreme conditions dictate the need for pedestrians to be completely separated from the roadway (or from railroad tracks or waterways). Overpasses and tunnels can provide safe pedestrian crossing

opportunities. However, they can also be extremely costly and make it difficult to provide accessibility, unless there is sufficient space for ramping (if not, elevators are necessary). In some cases, if the added travel distances are excessive, pedestrians who want the most direct route may be discouraged from using the grade separated crossing. The use and placement of grade separated crossings should be carefully considered. Criteria for determining the need for grade separation and additional design information is provided in Toolkit 7 — Crossings.

Traffic Circles — Roundabouts Versus Traffic Calming Circles

Various types of traffic circle designs exist around the world. Traffic circles provide different solutions for different traffic needs and some designs are more beneficial for pedestrians than others. There are two types of traffic circles commonly used — roundabouts and traffic calming circles. Roundabouts typically increase the volume of traffic traveling through intersections. Traffic calming circles decrease traffic speeds and are most appropriate on low volume streets.

Roundabouts are used at intersections in place of signals and carry significant traffic volumes. Their primary purpose is to provide motor vehicles free flowing mobility at a lower speed. Figure 78 illustrates an example of a modern roundabout design.

Traffic calming circles are used at low volume neighborhood intersections for speed control and to discourage through trips. Figure 79 illustrates an example of a traffic calming circle.

For these reasons, roundabouts typically create less favorable conditions for

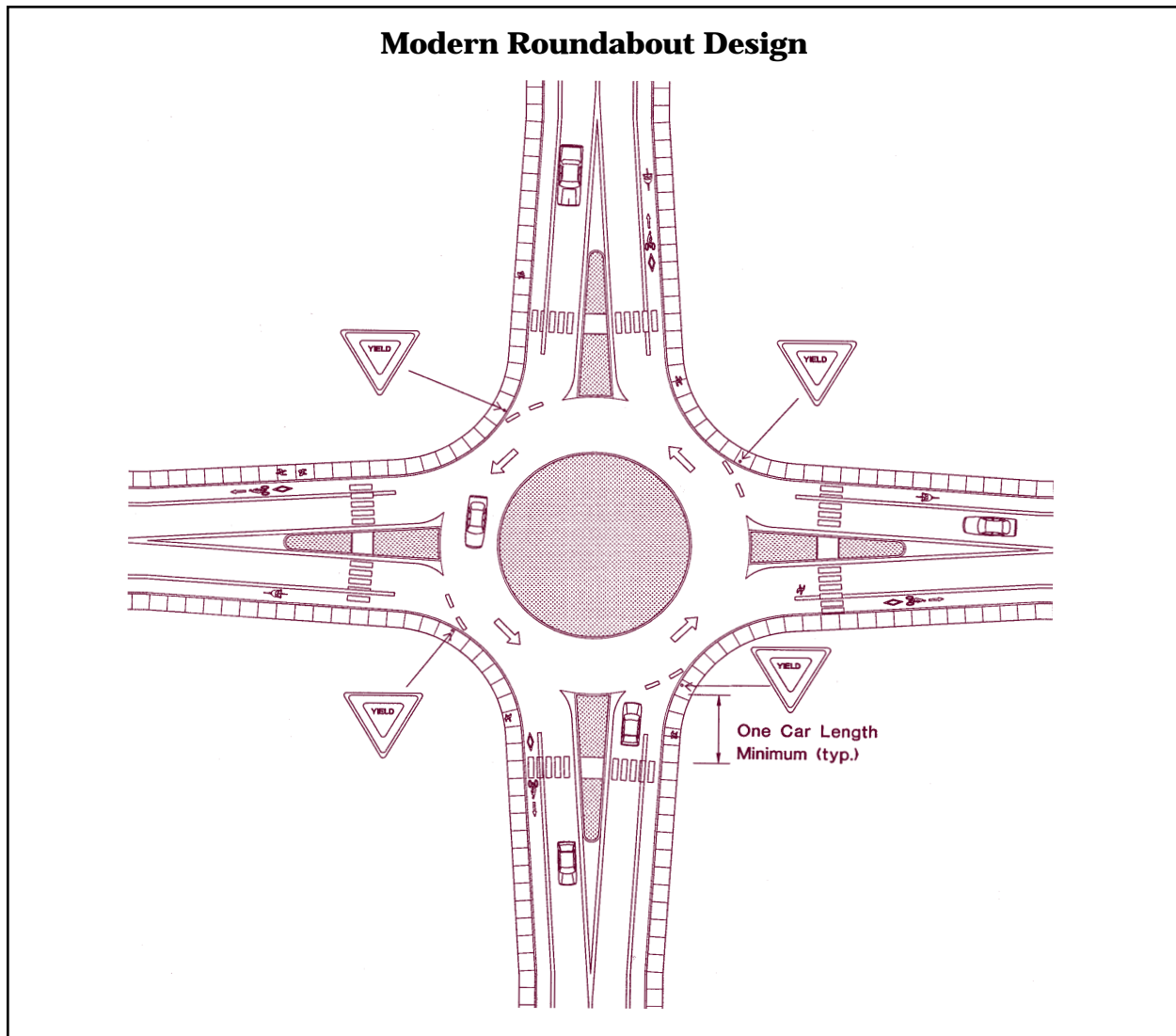

Figure 78

pedestrians than traffic calming circles. Characteristics related to roundabouts and traffic calming circles and their effect on pedestrian travel are summarized below. Additional information about traffic calming circles and other traffic calming devices is provided in Toolkit 8 — Traffic Calming.

Roundabouts

Modern roundabouts are designed to slow traffic, reduce delays, and handle higher traffic volumes. Research has shown fewer pedestrian collisions occur at roundabouts

than at signalized or unsignalized intersections. Properly designed roundabouts can create a positive environment for pedestrians.

Roundabouts allow pedestrians to cross frequently, without waiting for traffic to stop (when vehicular volumes are low to moderate). However, pedestrians crossing are not protected since vehicles are free flowing. Pedestrians identify and accept gaps in traffic and cross when it is safe.

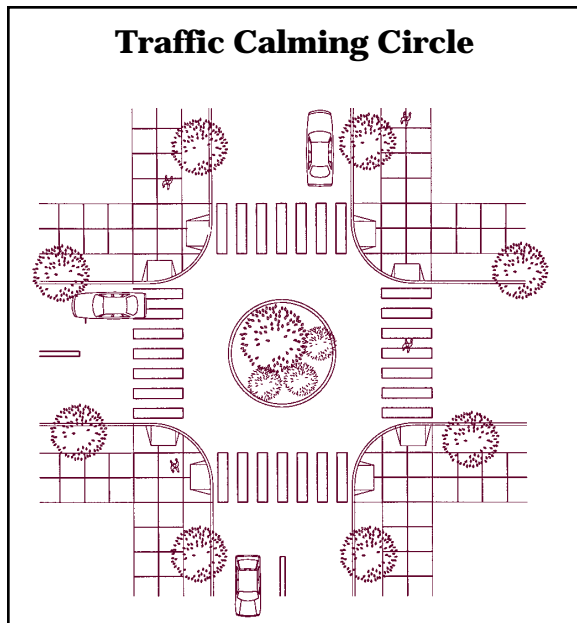

Figure 79

Splitter islands are used to deflect the path of motor vehicles and to slow them as they approach the roundabout. This deflection reduces vehicle speeds making it easier for pedestrians to cross the path of a vehicle entering the roundabout. Splitter islands also provide crossing refuge for pedestrians. Locate pedestrian crossings about 20 feet from the yield line. This allows pedestrians to cross behind the first motor vehicle trying to enter the roundabout.

Consider providing priority crossings where pedestrian volumes are high, or where there are many young, elderly, or disabled citizens wanting to cross or where pedestrian delays are long. Place these crossings at least 75 feet downstream of the exit and possibly add a pedestrian signal, particularly for larger roundabouts. Placing the pedestrian crossing further from the larger roundabouts helps to reduce backup of traffic into the roundabout when traffic is stopped.

Traffic Calming Circles

Traffic calming circles are very effective in reducing vehicle speeds and discouraging non-local trips through neighborhoods, which benefits pedestrians. Traffic calming circles also create a condition where vehicles are forced to stop or significantly reduce their speed at the intersection, which allows better opportunities for pedestrians to cross.

A drawback of some traffic calming circle designs is that vehicles need to swing wide at the intersection to avoid the center barrier and vehicles may intrude into the pedestrian crossing area if insufficient space is provided for the turning movement. A minimum of 4.0 meters (13 feet) of clearance between the circle edge and the crossing location is recommended when designing traffic circles. Another drawback is that some drivers try to take the shortest path through the traffic calming circle and turn toward the left, rather than going all the way around the circle. This creates an unexpected movement for crossing pedestrians.

Raised Intersections

In some cases, raised intersections may be a suitable solution, but this practice is still considered experimental in most areas. Raised intersections create an area that clearly functions for primary use by pedestrians. Approaching motorists can see that the intersection is not a location designed for rapid, through-movement, which causes them to slow down and yield the right-of-way to pedestrians. Raised intersections are not appropriate for high-speed thoroughfares and major arterials and collectors. Local requirements may prohibit their use under a variety of circumstances. Raised intersections may be most appropriate in urban centers and



Colored and Textured Paving in a Crosswalk

downtowns where traffic is already moving slowly through intersections.

Raised intersections make it easier to meet the ADA requirements because the crosswalk is a natural extension of the sidewalk, with no change in grade. Raised intersections require special treatment, such as tactile warning strips or audible signals, to make them detectable to the visually-impaired.

Placement of drainage inlets is simplified at raised intersections, because surface water will drain away from the center of the intersection.

Special Paving

Special paving techniques are commonly used to mark crossings at intersections in urban areas, particularly in special districts. Changes in pavement color and texture raise a motorist's awareness through increased visibility, noise, and vibration (see Figure 80).

Crossings constructed with special paving should use nonslip bricks or unit pavers. Scored or stamped colored concrete surfaces can also be used, and are generally more durable over the long term than unit pavers, with more uniform joints and less chance of

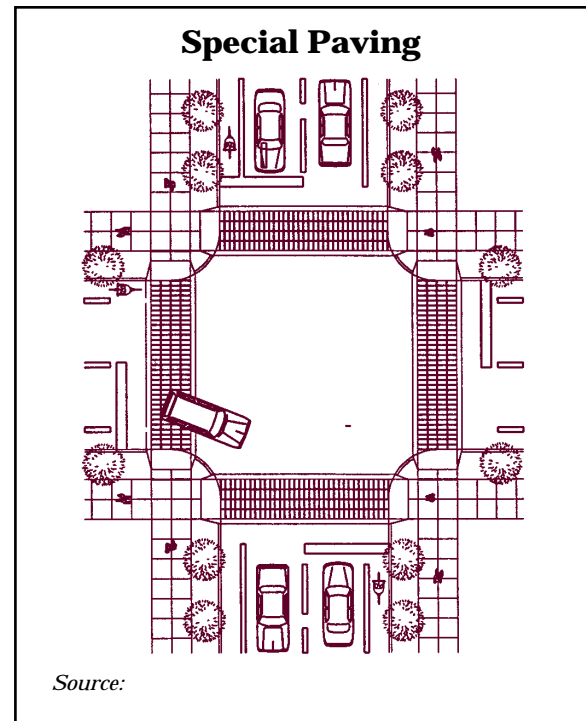

Source:

Figure 80

displacement. Special paving surfaces should be installed and maintained in a smooth, level, and clean condition. Care should be taken to ensure that grooves and joints do not impact accessibility.

Research is ongoing and design professionals and traffic engineers should investigate the benefits and disadvantages of the latest techniques and approaches when seeking to implement innovative treatments at intersections.

Other Sources of Information

The following sources of information are recommended for design of intersections. Please see the Resource Guide included at the end of this guidebook for complete bibliography information.



Intersections

A Policy on Geometric Design of Highways and Streets, 1994, American Association of State Highway and Transportation Officials

An Analysis of Pedestrian Conflicts with Left-Turning Traffic, Dominique Lord

Flashing Beacons, Association of Washington Cities and the County Road Administration Board

Curb Ramps for Accessible Pathways, Bureau of Transportation Engineering and Development, Office of Transportation, City of Portland

Design and Safety of Pedestrian Facilities, A Proposed Recommended Practice of the Institute of Transportation Engineers, ITE Technical Council Committee 5A-5

Design Manual, Washington State Department of Transportation

Field Studies of Pedestrian Walking Speed and Start-Up Time, Richard L. Knoblauch, Martin T. Pietrucha, and Marsha Nitzburg

Florida Pedestrian Planning and Design Guidelines, University of North Carolina

Guidelines for the Installation of Crosswalk Markings, Steven A. Smith and Richard L. Knoblauch

Handbook for Walkable Communities, Washington State Pedestrian Facilities Planning and Design Courses, Dan Burden and Michael Wallwork, PE

Manual on Uniform Traffic Control Devices for Streets and Highways, 1988 Edition, US Department of Transportation

Oregon Bicycle and Pedestrian Plan, An Element of the Oregon Transportation Plan, Oregon Department of Transportation Bicycle and Pedestrian Program

“Pedestrian Actuated Crosswalk Flashing Beacons,” John W. VanWinkle

Pedestrian Crossing Study, Final Submittal, Pedestrian Traffic Control Measures, Arctic Slope Consulting Group, Inc.

Pedestrian Improvements Demonstration Project, Kirkland Avenue at Main Street, Kirkland Avenue at Third Street, Lake Street South, Specifications and Contract Documents, KPG, Inc.

Pedestrian Signal Installation Policy, David I. Hamlin and Associates

“Pedestrian Signs at Crosswalks Spark Controversy in New Jersey,” *The Urban Transportation Monitor*, Volume 10, Number 19

PUFFIN and PELICAN Crossings to Reduce Delays, Office of the Minister for Roads and Ports

Unsignalized Pedestrian Crossings, New Zealand's Technical Recommendation, Roger C.M. Dunn

Crossings

This Toolkit Section Addresses:

- *Determining the Need for Mid-Block Crossings*
- *Mid-Block Crossing Design*
- *Railroad Crossings*
- *Grade Separated Crossings*
- *Multi-Use Trail Intersections and Crossings*
- *Boardwalks and Trestles*
- *Other Sources of Information*

This section discusses the need for and describes different types of mid-block crossing treatments, including marked crosswalks, mid-block actuated signals, median refuge islands, overhead signs, and flashing beacons. Standard practices, as well as some new techniques being tried around the country and in Canada are discussed. Other types of non-street intersection crossings, such as railroad crossings, grade-separated crossings, multi-use trail and pathway crossings, and bridges are also addressed. Crossing design treatments for street intersections are covered in Toolkit 6 — Intersections.

In all cases, the crossing treatment design applied to a specific location should be guided by a traffic engineering study of the existing conditions and intended function of the crossing.



Mid-block crossing with median refuge island.

Determining the Need for Mid-Block Crossings

In some urban areas where distances between intersections are long, mid-block crossing points provide pedestrians opportunities to cross safely. Mid-block crossings can also provide convenience and safety in less developed areas, where pedestrian activity is high (such as between an apartment site and a grocery store; a school and park; or a transit stop and a residential neighborhood). Figure 81 illustrates a typical mid-block crossing.

Locations being considered for a mid-block crossing needs to be carefully studied. The following guidance for determining locations for mid-block crossing installation is provided by the ITE manual, *Design and Safety of Pedestrian Facilities*:

- Where significant pedestrian crossings and substantial pedestrian/vehicle conflicts exist; (should not be used indiscriminately)
- Where the crossing can serve to concentrate or channelize multiple pedestrian crossings to a single location
- At approved school crossings or crossings on recommended safe school walk routes
- Where land uses create high concentrations of pedestrians needing to cross (such as residential areas across from retail or recreation, and transit stops across from residential or employment)
- Where pedestrians could not otherwise recognize the proper place to cross or there is a need to delineate the optimal location to cross

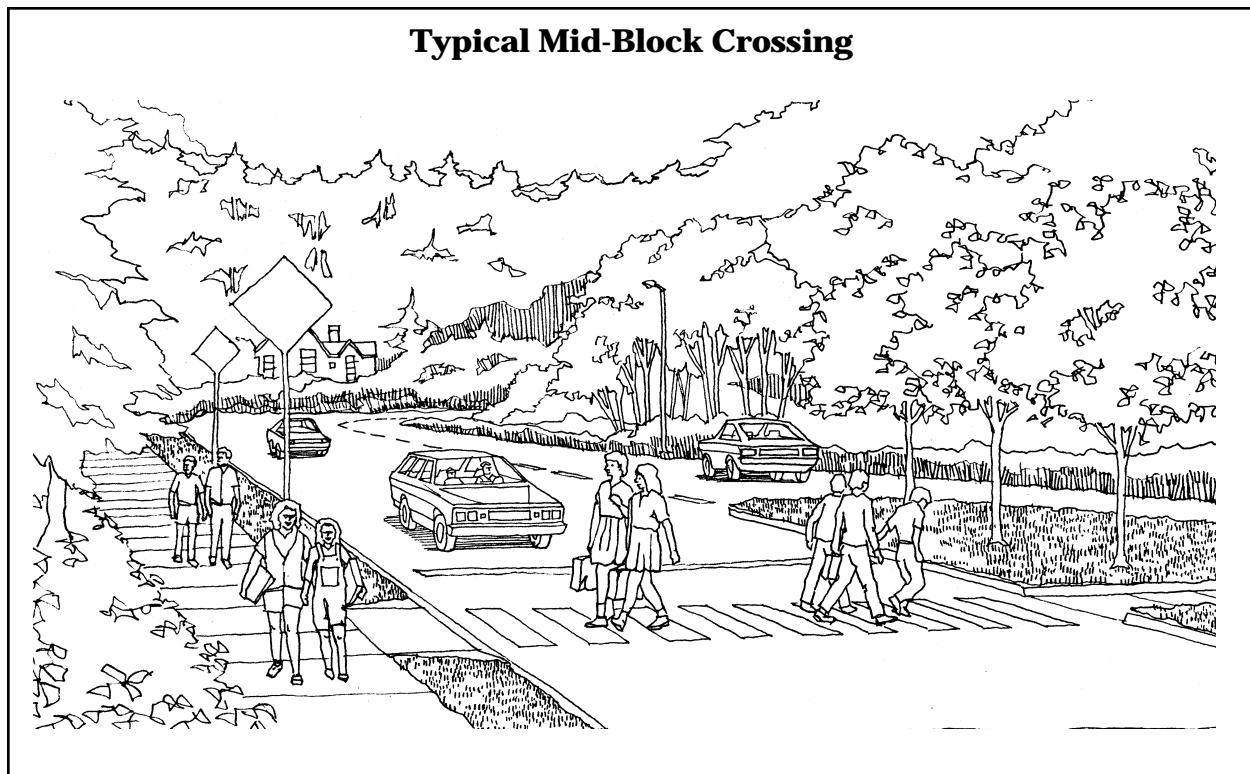

Figure 81

- Where there is adequate sight distance for the motorist and pedestrian. Any obstacles that would interfere with visibility at the crossing location (mailboxes, utility poles, street furniture, and landscaping) should be removed or relocated. On-street parking should be set back from the crossing point for improved visibility. Refer to Toolkit 6 — Intersections for recommended parking set back distances.
- Installed on the basis of an engineering study if located at other than an existing stop sign or traffic signal

Smith and Knoblauch developed criteria relating to pedestrian and vehicle volumes for determining where marked crossings should be located. Refer to Toolkit 6 — Intersections, which provides a chart illustrating this criteria. This chart also takes into account street widths and other factors (such as concentrations of children, elderly, and disabled pedestrians).

Mid-block crosswalks should generally be avoided under the following circumstances (unless they are stop controlled):

- Immediately downstream (less than 91 meters [300 feet]) from a traffic signal or bus stop where motorists are not expecting pedestrians to cross
- Within 183 meters (600 feet) of another crossing point (Knoblauch et. al.), except in central business districts or other locations where there is a well defined need. The recommended minimum separation in most cases is 91 meters (300 feet).
- On high speed streets with speed limits above 72 kph (45 mph)

Refer to Toolkit 6 — Intersections for design guidelines related to crosswalks, including some local agency approaches to crosswalk installation.

Mid-Block Crossing Design

Crossing design treatments are often used in combination with one another at mid-block crossings. Standard practices, as well as some more innovative techniques being tested around the country are described.

Determining methods of crossing design treatments and related traffic control requires careful consideration and traffic engineering analysis of existing conditions on a project by project basis.

Marked Crosswalks

It is strongly recommended that all mid-block crossings be marked with highly visible crosswalks, otherwise pedestrians and motorists may have trouble recognizing the designated crossing point. According to the Washington “Rules of the Road” (RCW 46.61.240), pedestrians are not allowed to cross at any place except in a marked crosswalk between adjacent intersections where traffic control signals are in operation. The rules also state that every pedestrian crossing a roadway at any point other than within a marked crosswalk or within an unmarked crosswalk at an intersection shall yield the right of way to all vehicles upon the roadway. These rules confirm that all mid-block crossings should be clearly marked so that they are easily recognizable to pedestrians and motorists.

It should be noted that marked crosswalks are meant to guide pedestrians to cross at the safest location. They are not safety devices to

protect pedestrians from vehicles. There have been studies that have shown that marked crosswalks may instill a false sense of security in pedestrians (see discussion in Toolkit 6 — Intersections). There are also concerns that when crosswalks are installed indiscriminately or too frequently, they may eventually become less obvious to motorists. For these reasons, it is important to fully consider the need for mid-block crossings before installation. Mid-block crossings should always include marked crosswalks, but mid-block crossings should only be located where a specific need has been determined.

Various crosswalk designs are discussed in Toolkit 6 — Intersections. The use of zebra, ladder, or piano bar markings are highly recommended over the use of other types of crosswalk markings because of their high visibility. Horizontal bars are not typically used at locations other than controlled intersections. Crosswalk markings should be at 90 degrees to the street to designate the shortest path for crossing and minimize pedestrian exposure. In refuge islands,

angling the crossing provides an opportunity for pedestrians to view oncoming traffic.

Stop lines or bars should be placed in advance of crosswalks. These are usually 0.3 to 0.6 meters (12 to 24 inches) wide solid white lines that extend across all approaching lanes. They are usually installed at a minimum of 1.2 meters (4 feet) in advance of the crosswalk to prevent motorists from encroaching into the pedestrian crossing space. Some jurisdictions install stop lines further in advance of crosswalks at mid-block locations to provide improved visibility and buffer distance between the motor vehicle and the crosswalk.

Raised pavement markers placed in rows, are often used in advance of mid-block crosswalks. If used, they need to be placed far enough in advance of the crosswalk for the rumble effect to provide adequate warning to the motorist. They should be placed in combination with and at the same distance as pedestrian advance warning signs to enhance motorist awareness. Because raised buttons and pavement markers can be an hindrance

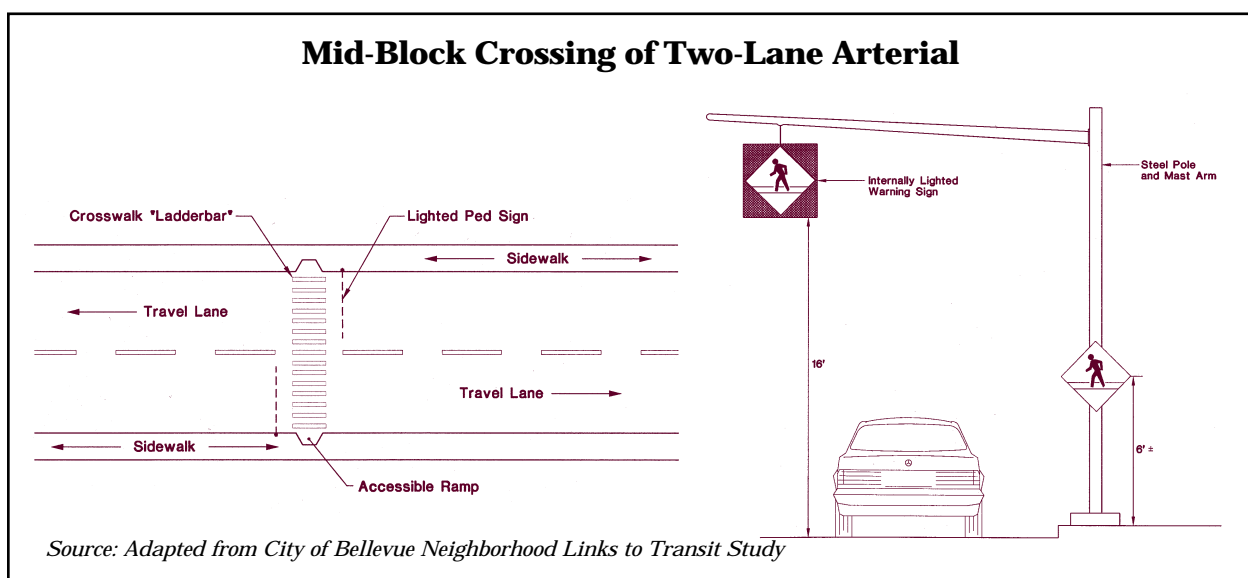

Figure 82

to bicycle travel, they cannot be placed adjacent to the right edge line or within bike lanes. A minimum clearance of 0.6 meters (2 feet) is recommended between such markers and any bicycle travel area. Raised pavement markers are difficult to maintain in areas of snow removal.

A mid-block crossing of a two-lane arterial is illustrated in Figure 82. Various types of devices that can be used in conjunction with crosswalks at mid-block locations are discussed below.

Mid-Block Pedestrian Actuated Signals

The MUTCD bases the need for pedestrian crossing traffic control on the number of adequate gaps or space between the vehicles in the roadway's traffic stream. It states that pedestrians must wait for a gap in traffic that is of sufficient duration to permit street crossings without interference from vehicular traffic. When the delay between adequate gaps or spaces becomes excessive, pedestrians may become impatient and endanger themselves by attempting to cross the street during inadequate gaps.



Pedestrian actuated signals at mid-block crossings only operate in the presence of foot traffic. Notice how median path directs pedestrians to look at oncoming traffic.

When adequate gaps occur less frequently than an average of once per minute, some form of traffic control is necessary. Pedestrian actuated signals or grade separated facilities should be considered as possible solutions for roadways with these characteristics.

Pedestrian actuated signals are often appropriate for roadways that have high traffic volumes or speeds, or four or more lanes. Since these signals only operate in the presence of foot traffic, they do not cause undue delay to vehicles during periods of low pedestrian volumes.

Pedestrian actuated signals should be considered in locations where pedestrian walk routes cross major arterials or other high volume or high speed facilities. A signal warrant analysis should be performed to study specific conditions and determine if a pedestrian actuated signal should be installed.

Medians and Refuge Islands

Medians and refuge islands are raised longitudinal spaces separating the two main directions of traffic movement in the street. Refuge islands are shorter than medians, typically up to 6.1 meters (20 feet) long, compared to over 30.5 meters (100 feet) long. Refuge islands are more commonly used at mid-block crossings than medians, but either provides major benefits for pedestrians and motorists.

Medians and refuge islands reduce crossing distances for pedestrians and effectively turn one two-way street into two one-way streets for pedestrians. Pedestrians only have to cross one direction of traffic at a time and can wait or rest in between. This creates a better opportunity for pedestrians to find gaps in the flow of traffic before crossing the street.



Mid-Block Refuge Island

Medians and refuge islands are a benefit to drivers when located at mid-block crossings, because they help to better identify the upcoming crossing point. They also provide a location for a pedestrian crossing sign in the middle of the street, providing another opportunity to warn drivers of the crossing.

Medians or refuge islands are recommended whenever crossing distances exceed 18.3 meters (60 feet) to provide a waiting and resting area for slower pedestrians. Medians

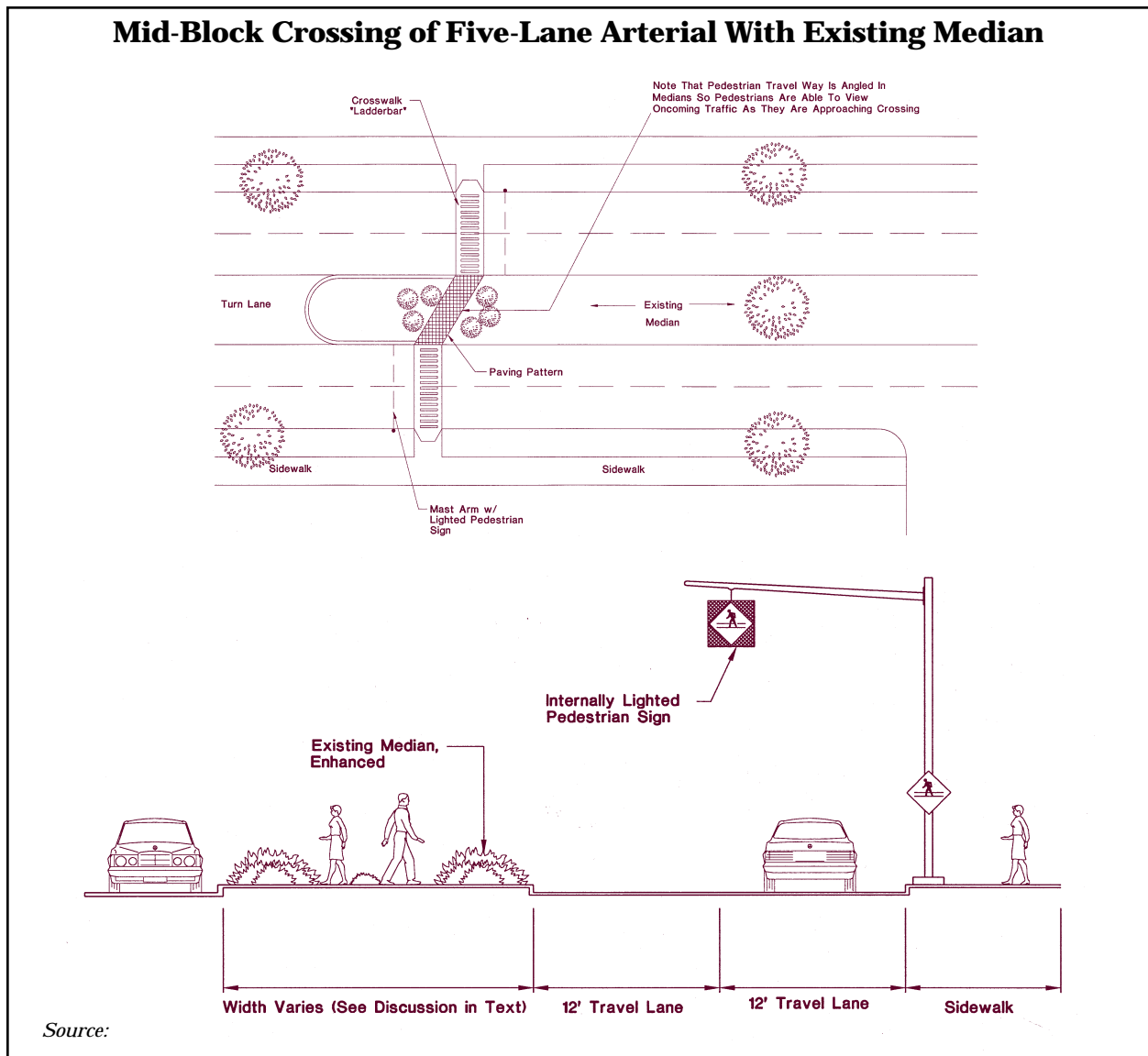

Figure 83

and refuge islands also can be designed to block side street or driveway crossings of the main road and block left-turning movements. Because medians reduce turning movements, they have the ability to increase the flow rate and safety of the roadway.

Refuge islands can be installed with more flexibility in a variety of locations because

they are shorter. Refuge islands are easily located on low volume, low speed roadways, such as 40 to 48 kph (25 to 30 mph) collectors or subcollectors through neighborhoods. When collectors are longer and handle more traffic and higher speeds, medians or refuge islands are helpful. On multi-lane minor and major arterials, raised medians or refuge islands are essential.

Design Guidelines for Medians and Refuge Islands

- Medians and refuge islands should be a desirable width of 2.4 to 3 meters (8 to 10 feet) wide and a minimum width of 1.8 meters (6 feet) wide to prevent wheelchairs propelled by attendants, bicyclists, and people with strollers from projecting out into the stream of motor vehicle traffic. In some cases, smaller width medians and refuge islands may be acceptable, particularly when there is limited space in the right-of-way, depending on local requirements and existing conditions (check with your local agency).
- In order to obtain appropriate median width, travel lanes can be narrowed to 3.3 meters (11 feet), if allowed by local standards. In locations where vehicle speeds range from 32 to 48 kph (20 to 30 mph), the travel lanes can be reduced further to 3.0 to 2.7 meters (10 or 9 feet), if allowed by local standards.
- Trees in medians and at the sides of streets can help to narrow the long range field of vision for approaching drivers, causing them to slow down as they near the crossing point. Landscaping in median refuge islands must be handled carefully. It is essential that landscaping not block the sight lines of pedestrians and motorists at the crossing area.
- Curb ramps or full cut-throughs should be installed in all median refuge islands. Cut-throughs are more common because the median width is sometimes not large enough to accommodate ramps that meet the ADA requirements. Cut-throughs should be designed with a 2 percent cross slope to allow water, silt, and debris to drain from the area.
- A pedestrian push button should be placed in the median of signalized mid-block crossings where the crossing distance exceeds 18.2 meters (60 feet).
- The use of angled (45 degrees±) refuge areas in the island should be considered (see figures later in this section). These provide the benefit of directing and encouraging pedestrians to look in the direction of oncoming traffic, helping them to be more aware of approaching vehicles. Pedestrians are also prevented from darting directly out into traffic.
- Medians and refuge islands should be illuminated.

Table 54

Figure 83 illustrates a mid-block crossing design. Table 54 lists several design guidelines for medians and refuge islands.

Raised Mid-Block Crossings

Raised mid-block crossings are sometimes constructed to provide a well-defined pedestrian crossing as well as traffic calming. This type of crossing is only suitable for low speed low volume local streets, since the raised crossing is essentially functioning as a speed table or hump.

Raised crossings enhance pedestrian safety by creating a vertical pavement undulation that forces motorists to slow down when approaching. Raised crossings function as an extension of the sidewalk and allow pedestrians to cross at a constant grade, without the need for curb ramps or median cut-throughs.

Raised crossings should have a 1.8-meter (6-foot) parabolic approach transition, raising the vehicle 7.6 to 10.2 centimeters (3 to 4 inches) above the nominal pavement grade. The flat section of the crossing table should be 3.0 to 3.7 meters (10 to 12 feet) wide.

Raised crossings need to be highly visible, either striped as a mid-block crossing or constructed of a contrasting pavement design



Raised Mid-Block Crossing

(such as unit pavers and stamped or colored concrete). The pavement surface must be smooth and stable, without deep grooves or joints to provide maximum accessibility (*A Guidebook for Residential Traffic Management*).

Raised crossings should be signed with advance warning signs and pedestrian crossing signs in the same manner as other mid-block crossings. Refer to Toolkit 8 — Traffic Calming for more discussion on traffic calming techniques.

Flashing Beacons

The use of flashing beacons is controversial, because if they are used indiscriminately, they eventually become “invisible” to motorists (see more discussion in Toolkit 3 — Children and School Zones). A crosswalk with a flashing beacon provides a relatively low cost treatment for mid-block pedestrian crossings. These devices are authorized by the MUTCD, under the sections related to hazard identification beacons. The flashing light alerts drivers in advance of potential pedestrians without forcing them to stop, unless there is actually a pedestrian in the crosswalk. This sort of device can be used on roadways with higher vehicular volumes without causing any undue delay to drivers.

Flashing beacons are most effective if they are operating only during times when there is a clear need to alert the motorist, like when pedestrians are actually present (rather than constantly flashing all the time). Some communities around the country are experimenting with different types of pedestrian actuated flashing beacons.

In California and some east coast states, flashing lights are being installed at grade to identify crosswalks to motorists at night. A



Overhead Flashing Beacon

few jurisdictions around the county are experimenting with strobe lights imbedded in the pavement. The flashing lights only operate when a pedestrian is crossing. The lights are designed and installed at a level so that they can be an effective warning, without impairing nighttime vision.

A pedestrian-actuated flashing beacon has been used successfully for a number of years in Chattanooga, Tennessee (*ITE Journal*, January 1997). The typical design consists of overhead signs with the message “Yield to Pedestrians — 25 MPH When Flashing” with dual 20-centimeter (8-inch) beacons mounted approximately 91 meters (300 feet) in advance of the crosswalk in both directions. Push buttons are mounted on pedestal poles on both sides of the crosswalk, along with auxiliary flashers that confirm to the pedestrian that the overhead beacons have been activated. Signs are also posted instructing the pedestrian in the use of the flashers. Once activated, the beacons are controlled by a timer housed in the flasher cabinet. For more information, contact the Chattanooga City Traffic Engineer at (423) 757-5005.

Advance Warning Signs and Pedestrian Crossing Signs (Side or Overhead)

Advance Pedestrian Crossing signs should always be installed in advance of mid-block crossings (MUTCD Sign W11-2; see Figure 84). Placement of advance warning signs depends on the speed of motor vehicle travel and other conditions, such as available sight distance. Refer to the MUTCD for sign placement criteria.

Advance Pedestrian Crossing signs should not be mounted with another warning sign (except for a supplemental distance sign or and advisory speed plate) or regulatory sign (except for NO PARKING signs) to avoid information overload and allow for an improved driver response.

The Pedestrian Crossing sign (MUTCD Sign W11A-2; see Figure 84) is similar to the Advance Pedestrian Crossing sign, but has the crosswalk lines shown on it. This sign should be used only at the crosswalk location and not in advance of it. This sign is now commonly being placed overhead of the crossing on a steel pole and mast arm. In some situations the sign is equipped with internal lighting for increased visibility at night.

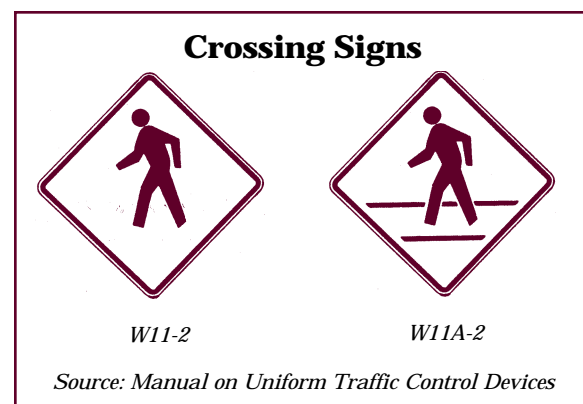

Figure 84

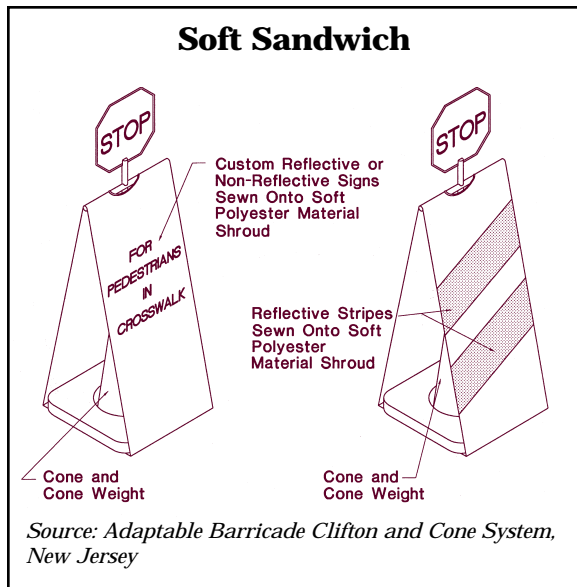

Figure 85

Soft Sandwich

This technique is being used in New Jersey and involves the use of heavy plastic “sandwich board” signs cautioning motorists to yield to pedestrians. These signs are typically placed in the center of the roadway (see Figure 85). Earlier “hard” versions of these signs were banned by the New Jersey DOT because they could become projectile objects when hit by a vehicle. Some towns are now testing flexible or “soft” versions of these signs that will not injure pedestrians or cars when hit. Contact the New Jersey DOT for more information.

PUFFIN and PELICAN Crossings

Victoria, British Columbia is experimenting with signalization techniques that help to reduce delays for motorists and pedestrians at pedestrian crossings. PUFFIN (Pedestrian User Friendly INtelligent) signals involve the use of special microwave detectors that sense the presence of pedestrians in the crossing and prevent the light from changing until all

pedestrians have cleared the roadway. PUFFIN crossings can help at locations where there is high usage by slow moving pedestrians (hospitals, schools, and retirement homes).

PELICAN (PEdestrian LIght CONtrolled) signals are different from usual pedestrian operated signals in that motorists will face a yellow flashing light sequence in the change over from red to green that allows drivers to proceed if there are no pedestrians in the crossing. For more information on these techniques, contact Nick Mahaer, Office of the Minister for Roads and Ports, Victoria, B.C.

Portable Pedestrian Flags

The City of Kirkland has been experimenting with portable orange flags at intersections and mid-block crossings. The flags are being used by some people (but not by everyone) and have been viewed as an effective measure to increase driver awareness of upcoming crossing activity. People who are using them say they feel more comfortable crossing while holding the flags. The City has experienced some loss of flags to vandals, but overall reports that the program has been successful (see Figure 86).

Other Design Considerations

It is usually necessary to supplement the existing street lighting system with additional lighting at new mid-block crossing locations. It is extremely important that these crossing locations be well-illuminated, so they are clearly visible to motorists driving at night.

Fences, barriers, signs, or sidewalk ramps can be used at mid-block crossings and refuge islands to channelize pedestrians to the crossing. Trees and landscaping can also be used to enhance and identify the crossing

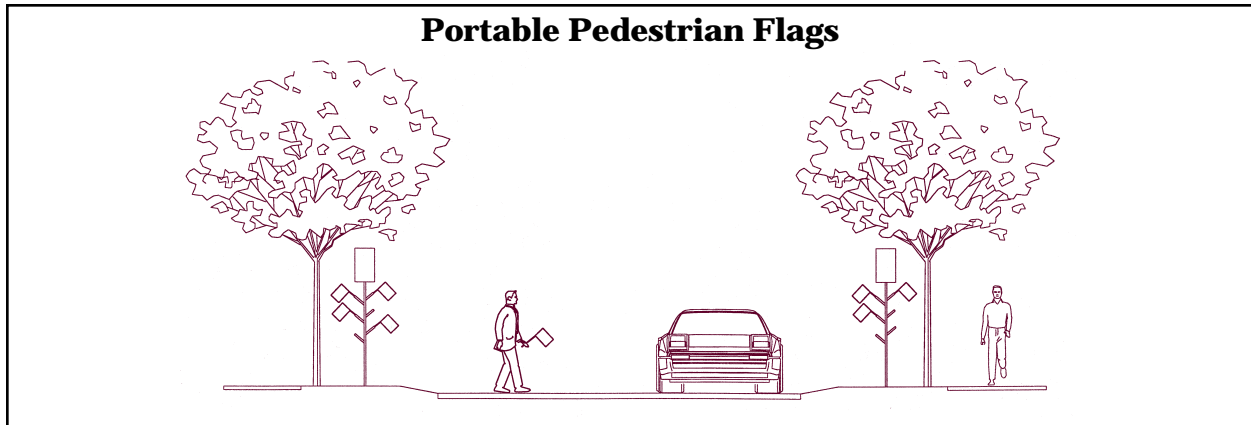

Figure 86

area, but care must be taken to ensure that these do not obstruct visibility at the crossing in any way.

See Toolkit Section 6 — Intersections for recommended setback distances for on-street parking.



Railing is used to channelize pedestrians so they can view oncoming traffic.

Railroad Crossings

Crossing Design Options

At-grade railroad crossings can be difficult for pedestrians to negotiate. They differ from roadway crossings in that when a train

reaches a crossing it always has the right-of-way and cannot stop to avoid a pedestrian. There are three types of railroad crossing designs: those with crossbuck signs, those with crossbucks and flashing light signals, and those featuring automatic gates in addition to the crossbucks and flashing lights.

Pedestrian safety improvement options are limited at these locations, since stopping the train is not a viable option. The only recourse to improving conditions for pedestrians is to improve the method of stopping pedestrians or to grade separate pedestrians from the tracks. If the crossing is heavily used by pedestrians on a daily basis (located on a school walk route, or near pedestrian origins



Railroad crossings are different than road crossings in that trains always have the right-of-way.

and destinations), it is recommended that it be designed to include the crossbuck sign, flashing light signals, and automatic gates. A warrant analysis should be completed to determine if grade separation is a suitable solution. Another lower cost solution for crossings located on school walk routes is to assign a crossing guard to that location.

Surface Smoothness

The smoothness of the surface is an important consideration, especially when providing crossings that are part of an accessible route of travel. Concrete used at the crossing area provides smoothness and performs best under wet conditions. Rubberized material can provide a durable, smooth crossing, but can become slippery when wet. If asphalt pavement is used, it must be regularly maintained to prevent ridge buildup next to the rail lines. Timber crossings wear down rapidly and are slippery when wet. The ADA requires smooth surfaces and a maximum lift tolerance between surfaces or at pavement joints of 1.3 centimeters (0.5 inches).

Signing and Marking

It is desirable for stencils and signs to be placed prior to railroad crossings to warn oncoming pedestrians, bicyclists, and motor vehicles, particularly at locations with heavy pedestrian activity.

Angle of Crossing

Since trains may be coming in either direction, the optimum condition is for pedestrians to cross at a 90 degree angle to the rail line.

Grade Separated Crossings

Determining the Need for Grade Separated Crossings

Grade separated pedestrian crossings are installed when it is necessary to physically separate the crossing of a heavy volume of pedestrians from a roadway with heavy motor vehicle traffic (including freeways and expressways). Grade separation is also used at some railroad crossings and water crossings.

The effectiveness of grade separated crossings depends on their perceived ease of accessibility by pedestrians. An overpass or underpass will not necessarily be used simply because it improves safety. Because of the high cost of grade-separated facilities, they should be incorporated into the early stages of new developments that are intended to generate substantial volumes of pedestrians. According to a study by Zegeer and Zegeer, state and local agencies consider grade-separated crossings to be most beneficial under the following conditions:

- Moderate to high pedestrian demand to cross a freeway or expressway
- Large number of young children (particularly near schools) who must regularly cross a high-speed or high-volume roadway
- Streets with high vehicle and pedestrian crossing volumes where there is an extreme hazard for pedestrians (for example, wide streets with high speed traffic and poor sight distance)

- Where one of the above conditions exists in conjunction with a well-defined pedestrian origin and destination (residential neighborhood across a busy street from a school, a parking structure affiliated with a university, or an apartment complex near a shopping mall)

Refer to the ITE manual *Design and Safety of Pedestrian Facilities*, the WSDOT *Design Manual* (Section 1020 Facilities for Nonmotorized Transportation), and the MUTCD for more specific information and warrants to determine the need for grade separated crossings.

Overpasses and Bridges

Overpasses and bridges should be easy and convenient for pedestrians to access. If a grade separated crossing would be less convenient than the at-grade condition, some pedestrians may try to cross at grade, which is not desirable when the purpose of the crossing is to increase safety. Pedestrian bridges can vary in their structure and may be constructed of cast-in-place concrete, prestressed concrete, steel, or wood. Choosing the appropriate type of structure requires knowledge of the conditions at the proposed location. Consideration should be given to cost, constructability, maintenance, aesthetics, and physical site constraints.

Structure Selection

The type of structure will depend on the span length of the bridge as well as the available depth for the superstructure. The depth is usually controlled by the deflection of superstructure due to live load. Since pedestrians will be sensitive to movements of the bridge, a maximum deflection of span length divided by 1,000 should be used. Based on this deflection, the required depth for any given span length can be determined.

Cast-in-place concrete generally has the longest life and the least future maintenance, but it is difficult to construct over an existing roadway that requires continuous traffic flow. Steel usually has a smaller depth to span ratio, but is more costly than concrete. Wood is used for bridges in rural or forested areas, but requires considerable maintenance. Prestressed concrete slabs and girders are readily available and easy to install for short to medium spans.

For example, a steel or wood structure would create less dead load to a foundation than a concrete structure.

Aesthetics

The type of structure chosen should complement the site where it will be located. Different materials are more appropriate in different settings. For instance, a timber truss would fit a rural setting, whereas a steel truss would fit an industrial setting. When designing the structure, detail structural elements to blend with the environment. Taper girder haunches or arch superstructure to create a structures that are aesthetically appealing.

Design Load

AASHTO and WSDOT require a design live load of 38.6 kilograms per square foot (85



Pedestrian Bridge Over Sammamish River

pounds per square foot). Some local building codes require a design live load of 45.4 kilograms per square foot (100 pounds per square foot). Other loads, such as seismic, stream flow, and wind loads should also be considered in accordance with applicable codes. If the structure is to provide access for emergency or maintenance vehicles, the appropriate design loads should be used.

Geometry

With accessibility requirements resulting in ramped accessible bridges, all bridges must be assumed to provide service to both pedestrians and bicyclists. As a result, a railing to railing width of 3.7 meters (12 feet) is preferable. If a bridge is to accommodate emergency or maintenance vehicles, a 3.7-meter (12-foot) width is mandatory.

Bridges built over roadways must maintain 5.3 meters (17.5 feet) of clearance under the structure. Since pedestrian bridges are lighter than vehicular bridges and would sustain greater damages from vehicle impact, it is good practice to provide 5.5 to 6.7 meters (18 to 22 feet) of clearance to prevent damage. Clearance over railroad tracks is controlled by the railroad company but is generally at least 7.0 meters (23 feet). Bridges built over waterways must maintain a minimum clearance above the 100-year flood level



Above Grade Crossing in Seattle



Ramp Leading to Overhead Crossing in

(check local guidelines for clearance). Bridges over navigable waters must satisfy requirements of the Coast Guard. Figure 87 illustrates typical geometry of overhead crossings.

Approaches to bridges should consist of ramps that meet ramp accessibility standards discussed in Toolkit 2 — Accessibility. If ramps are not feasible or would provide a deterrent to using the bridge due to long length, elevators should be installed to provide users access to the bridge.

Safety

For information on protective screening refer to WSDOT/AASHTO. For bridges near schools, overhead fencing is recommended. Railings 1.4 meters (4.5 feet) in height are required on both sides of the bridge. Refer to the WSDOT *Design Manual* (Section 1020 Facilities for Nonmotorized Transportation) for design guidelines related to railings on bridges.

Skywalks and Skyways

Skywalks or skyways are fully enclosed walkways between buildings at mid-block. They allow pedestrians to pass between buildings without going to street level or being exposed to weather. Design of skywalks



Skywalk in Spokane

will largely be determined by the buildings into which they are built and thus are not discussed in detail in this guidebook. Skywalks can function successfully, especially in areas where inclement weather is common. One note of caution related to the use of skywalks: some communities have experienced a loss of pedestrian activity at the street level, negatively impacting the retail businesses and economic vitality of the area. When skywalks are being considered, ways to ensure that street level retail will still be fully accessible and inviting to pedestrians need to be identified.

Underpasses and Tunnels

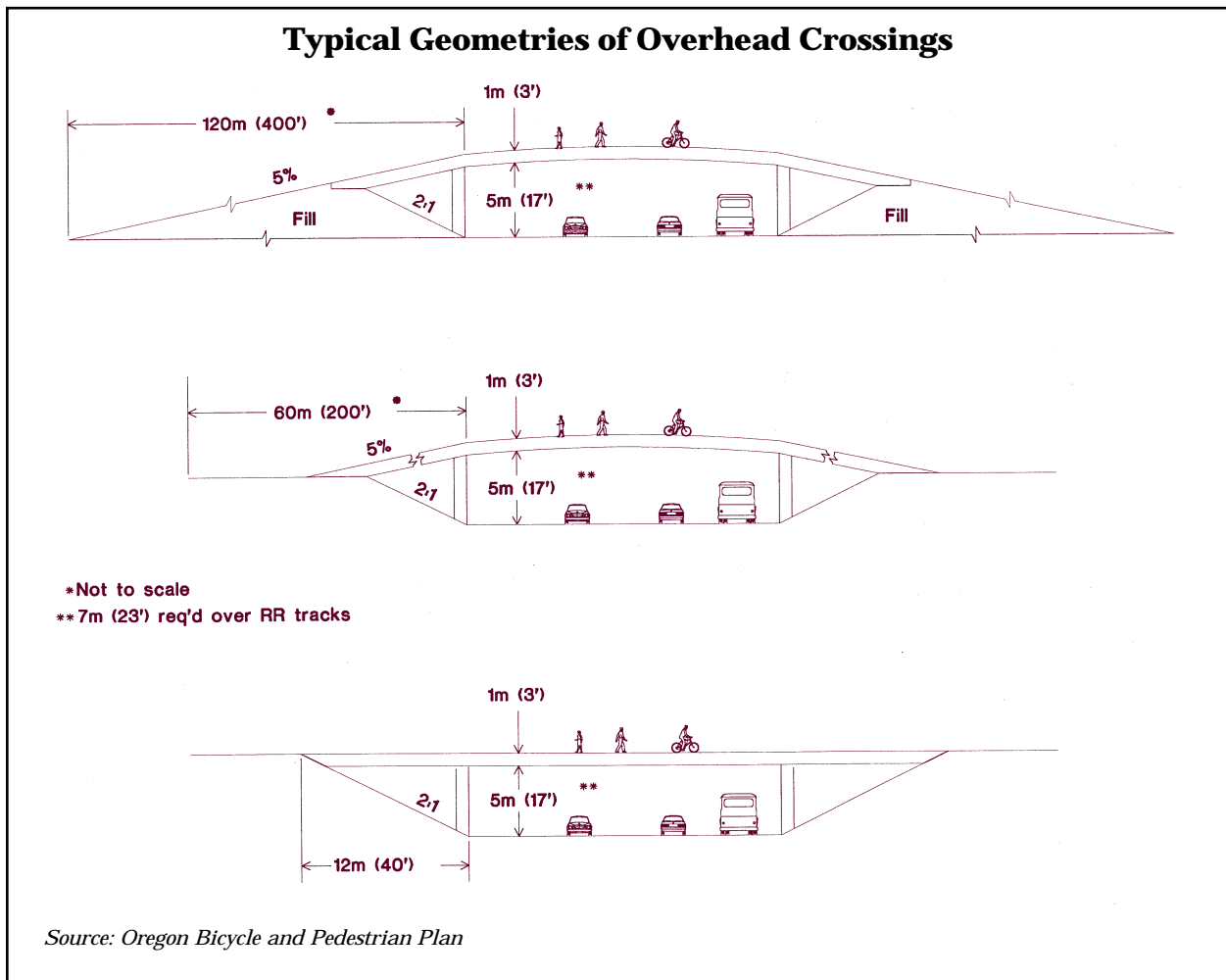

Figure 87

Tunnels and underpasses provide a walkway for pedestrians underneath the roadway. Pedestrians are often more apt to use overpasses than underpasses or tunnels, and overpasses are easier to supervise and maintain. Tunnels are less desirable than bridges due to greater potential costs and the possibility of drainage problems causing increased maintenance. Before choosing to install a tunnel, soil exploration is required to determine whether a tunnel is constructible and whether drainage will be a problem.

Tunnels can be designed to let more natural light in and with wide openings to be more inviting to pedestrians. To encourage maximum pedestrian use, tunnels should be easy to access and should be as short as possible.

Geometry

When designing tunnels for pedestrians, the alignment with approaching walkways must provide the pedestrians with a clear view of the end of the tunnel. One way to accomplish this is to raise the roadway about halfway to

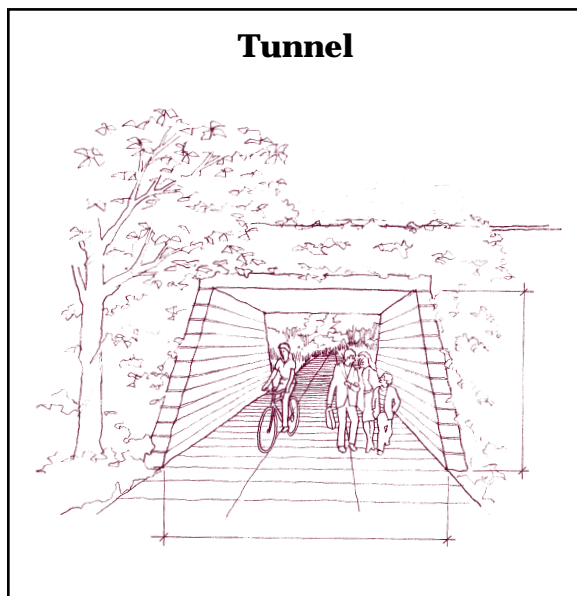

Figure 88

reduce the change in elevation for the tunnel. Tunnels and underpasses created by a vehicular overcrossing must have an overhead clearance of at least 3.0 meters (10 feet) and be at least 3.7 meters (12 feet) wide to accommodate bicycle travel. Figure 88 illustrates a typical tunnel design, with wide openings at either end that serve to let more light into the tunnel and make it feel less imposing on pedestrians and Figure 89 illustrates typical geometries of underpasses.

Safety

Tunnels must be well lit throughout. Poorly illuminated tunnels will discourage pedestrian use. The ITE manual, *Design and Safety of Pedestrian Facilities*, recommends placing tunnels near places of high activity such as entertainment complexes or other activity centers. This helps to discourage crime in and around the tunnel.

Multi-Use Trail Intersections and Crossings

Treat trail crossings the same as a roadway intersection. There should be adequate sight distance, traffic control (as warranted), medians or refuge islands, pavement markings, signing, lighting, access control, and other devices to ensure the safest possible condition for trail users and motorists. Curb cuts should be provided, as well as median cut-throughs if necessary, to facilitate bicycles, wheelchairs, and strollers. Information related to multi-use pathway intersections with roads is provided in Toolkit 4 — Trails and Pathways. A very comprehensive source of information on trail intersection design is *Trail Intersection Design Guidelines*, by the North Carolina Highway Safety Research Center, prepared

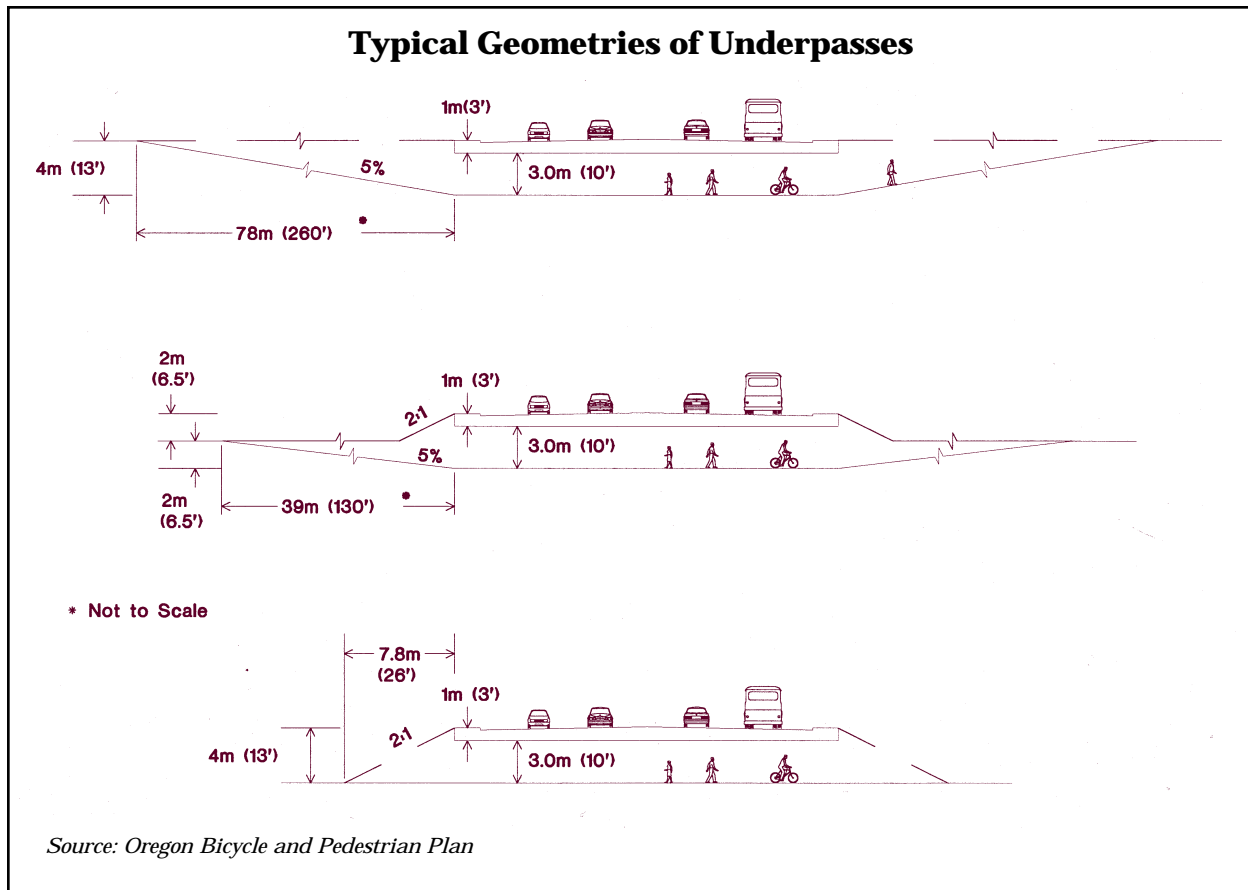

Figure 89

for the Florida Department of Transportation in June 1996.

Boardwalks and Trestles

Boardwalks and trestles are simply small bridges consisting of multiple small spans. Boardwalks are usually only a few feet above grade. They provide a walkway that is just above the ground to allow pedestrians access across sensitive and previously inaccessible areas, such as wetlands and streams in parks. Boardwalks and trestles are attractive in natural settings because they are typically constructed of wood.

The basic design, geometry, and safety criteria for boardwalks and trestles are the same as bridges. A few more specific considerations are summarized below.

Boardwalks and trestles are surfaced with wood decking, which can be an accessible surface, if the spaces between the decking do not exceed 0.6 to 1.3 centimeters (0.25 to 0.5 inches) and the deck boards are attached evenly, with no boards, screws, or nails protruding from the surface.

When there is a drop off the edge of the boardwalks of less than 0.8 meters (2.5 feet), an edge (wood or other material) needs to be provided to keep wheelchairs and strollers directed onto the decking surface. For grade drops of more than 0.8 meters (2.5 feet), a full



Wood Trestle With Edge

railing needs to be provided (see Toolkit 4 — Trails and Pathways and Toolkit 5 — Sidewalks and Walkways for railing design recommendations).

A good resource for information about design of boardwalks and trestles is *Time-Saver Standards for Landscape Architecture*.

Other Sources of Information

The following sources of information are recommended for design of crossings. Please see the Resource Guide included at the end of this guidebook for complete bibliography information.

A Guidebook for Residential Traffic Management, Final Report, Washington State Department of Transportation

A Guidebook for Student Pedestrian Safety, Final Report, KJS Associates Inc.

A Policy on Geometric Design of Highways and Streets, 1994, American Association of State Highway and Transportation Officials

An Analysis of Pedestrian Conflicts with Left-Turning Traffic, Dominique Lord

Flashing Beacons, Association of Washington Cities and the County Road Administration Board

“A Toolbox Approach to Residential Traffic Management,” Joseph Savage and R. David MacDonald

Bellevue Transit Neighborhood Links Project, Otak, Inc.

“Boulder Brings Back the Neighborhood Street,” John Fernandez

Design and Safety of Pedestrian Facilities, A Proposed Recommended Practice of the Institute of Transportation Engineers, ITE Technical Council Committee 5A-5

Design Manual, Washington State Department of Transportation

Flashing Beacons, Association of Washington Cities and the County Road Administration Board

Guidelines for the Installation of Crosswalk Markings, Steven A. Smith and Richard L. Knoblauch

Handbook for Walkable Communities, Washington State Pedestrian Facilities Planning and Design Courses, Dan Burden and Michael Wallwork, PE

Manual on Uniform Traffic Control Devices for Streets and Highways, 1988 Edition, US Department of Transportation

NE 124th Street Sidewalk, 100th Avenue NE and 108th Avenue NE Median Islands, Specifications and Contract Documents, KPG, Inc.

Oregon Bicycle and Pedestrian Plan, An Element of the Oregon Transportation Plan, Oregon Department of Transportation Bicycle and Pedestrian Program

"Pedestrian Actuated Crosswalk Flashing Beacons," John W. VanWinkle

Pedestrian Crossing Study, Final Submittal, Pedestrian Traffic Control Measures, Arctic Slope Consulting Group, Inc.

"Pedestrian Signs at Crosswalks Spark Controversy in New Jersey," The Urban Transportation Monitor

Proposed Warrants for South African Mid-Block Pedestrian Crossings, H. Ribbens, G. Brafman Bahar

PUFFIN and PELICAN Crossings to Reduce Delays, Office of the Minister for Roads and Ports

Streetscape Manual, City of Toronto

Unsignalized Pedestrian Crossings, New Zealand's Technical Recommendation, Roger C.M. Dunn

Traffic Calming

This Toolkit Section Addresses:

- *Why Is Traffic Calming Used?*
- *Residential Traffic Management*
- *Traffic Calming and Management Methods*
- *Other Sources of Information*

Traffic calming uses various techniques to reduce vehicle speeds, vehicle noise, visual impacts, and through traffic volumes. Traffic calming techniques use various means to influence the behavior of motorists: physical, psychological, visual, social, and legal (regulatory and enforcement).

Even though traffic calming is not specifically a “pedestrian facility,” it relates to pedestrians by improving their environment. There are many good resources that provide information about the effectiveness and design approaches related to traffic calming methods. This toolkit provides an overview of some of the more common types of traffic calming methods used. Please refer to the list of sources at the end of this section to obtain more specific information related to design and application of these techniques.



Traffic Circle in Residential Neighborhood



Why is Traffic Calming Used?

In the last decade, collisions between motor vehicles and pedestrians or bicyclists were the second leading cause of accidental deaths in Washington State for children between 5 and 14 years old. Studies show that most young pedestrians (under 15) killed or injured were crossing the road mid-block; lower collision levels occurred at intersections. Most pedestrian collisions occur from 3:00 to 6:00 pm, when children are most likely to be walking home from school, or out in the neighborhood, and also the time when most vehicles are on the road.

In the United States, the need for reduced speeds in residential areas is echoed in ITE's *Handbook on Residential Street Design*, published in 1989:

"...research has shown that pedestrians are not usually seriously injured when hit by a car moving at a speed of less than 20 miles per hour (30km/h) at the time of impact. If impact speeds are between 20 and 35 mph (30 and 55 km/h), injuries are usually serious, while at speeds above 35 mph (55 km/h) they usually endanger life and are fatal."

Statistics provide important insight into the need to improve traffic conditions to increase pedestrian safety. Along with this increasing need, a trend for more livable and sustainable communities has been gaining momentum over the past several years. People are demanding that their neighborhoods become less oriented toward automobiles and more oriented toward walking, bicycling, and access to transit.

Residential Traffic Management

Traffic calming programs seek to reduce traffic speeds and volumes on neighborhood streets to make them safer for pedestrians, bicyclists, and residents with special regard for children.

Although traffic management and calming techniques are often used in areas other than residential neighborhoods, most programs are focused in residential areas, where traffic problems are more prevalent and have the most influence on the day to day livability of the community. There are also more opportunities for traffic management approaches to be successful in residential areas, where they are typically applied on a wider basis. A wider range of techniques is generally more acceptable in residential areas where streets provide local access and do not function as major conveyors of commuting traffic or as primary emergency routes.

When traffic calming techniques are applied to identified target neighborhoods and districts, rather than in isolated locations, the behavior of motorists tends to be more significantly influenced and the traffic problems of the area are more noticeably improved. Isolated applications can be problematic because they may divert traffic to other areas in the neighborhood rather than managing it on an area wide basis.

Residential traffic management programs seek to make residential streets safer and reduce traffic intrusion by reducing traffic speeds and to a lesser extent, traffic volumes. Figure 90 illustrates a typical urban neighborhood and its traffic related problems, and how these can be resolved through the use of various traffic management tools.

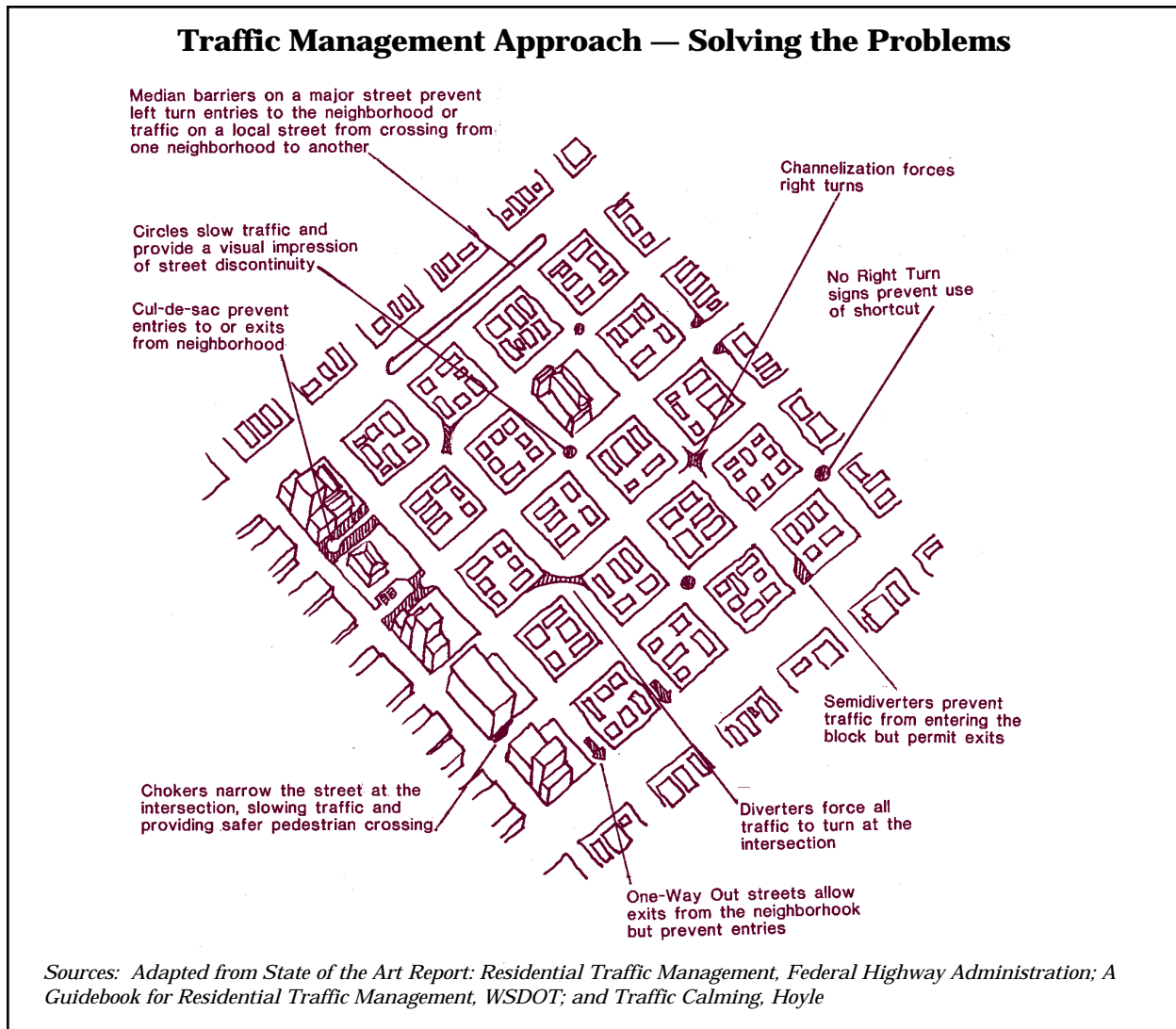

Figure 90

Traffic Calming and Management Methods

A Guidebook for Residential Traffic Management (KJS Associates, Inc.), published by WSDOT, identified references to more than 80 individual traffic control devices or measures that have been used for residential traffic management. These devices ranged from traffic circles and speed humps to variable spaced transverse pavement markers and odd speed limit signs (for example, “16”

mph). The reported levels of success and application feasibility of these devices varied greatly as well. Table 55 illustrates common actions of residential traffic management programs.

Table 56 illustrates some of the more common types of traffic calming methods currently used. Each of the techniques illustrated and described can be effective in managing traffic and creating improved conditions for pedestrians. These techniques have shown successful results in slowing traffic and reducing collisions on residential streets.

Common Residential Traffic Management Program Actions

<i>Reducing</i>	<i>By What Means</i>	<i>Examples</i>
Traffic volumes	Physical	Traffic circles, traffic diverters
Vehicle noise	Psychological	Variable-spaced paint stripes
Visual impacts	Visual	Landscaping to block through views
Traffic speeds	Social; physical	Neighborhood "Speed Watch" program; speed humps/tables
Collisions/speeding	Legal; physical	Strict speed enforcement; spot safety improvements

Source: Adapted from A Guidebook for Residence Traffic Management

Table 55

Common Types of Traffic Calming Methods

<i>Drawing</i>	<i>Technique</i>	<i>Description</i>
	Traffic Circles	Circular raised islands centered within intersections. Circles can be landscaped or surfaced with special paving. Landscaping can be maintained by the local jurisdiction or by neighborhood volunteers.
	Chicanes	Alternately placed curb extensions into the street that force motorists to drive in a serpentine pattern. Chicanes are offset from each other in mid-block locations and can be used to keep through-trucks versus local delivery off residential streets.
	Curb Bulb-Outs, Chokers/ Neckdowns	Curb extensions placed at mid-block locations or intersections which narrow the street to provide visual distinction and reduce pedestrian crossing distances. Bulb-outs help to provide a clear visual signal to drivers that a crossing is approaching and makes waiting pedestrians more visible. Neckdowns are often longer than bulb-outs and often line up with and help to define parallel street parking areas. They narrow the appearance of the street and can be attractive, especially when landscaped.

Table 56

Common Types of Traffic Calming Methods
(Continued)

<i>Drawing</i>	<i>Technique</i>	<i>Description</i>
	Diagonal Diverters	Eliminates through traffic while providing partial access in opposite directions; island can become amenity and provide refuge for pedestrians.
	Forced Turns and Partial Diverters	Truncated diagonal diverters (one end remains open) and other types of partial diverters discourage commuter traffic by forcing turns, but provides local access opportunities
	Cul-de-sac/Street Closures	Street is closed and turned into a cul-de-sac; end of street becomes a neighborhood amenity and focal point (landscaped mini park); the ongoing provision of pedestrian and bicycle access is important.
	One-Way Entry and Exit	Curb bulbs/extensions are used to close one lane of traffic at intersections; stops through traffic but allows ingress or egress depending on the direction and location of the closure.
	Narrower Streets	Narrower streets limit the expanse of pavement visible to the driver and can be effective in slowing traffic, especially when lined with trees or on-street parking.
	Speed Humps/Tables	A speed hump is wider and smoother than a speed bump, and effective in slowing cars as they approach pedestrian zones. These are most appropriately used on neighborhood streets.

Table 56 (Continued)

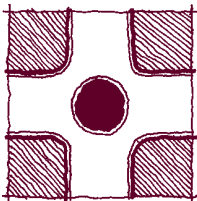
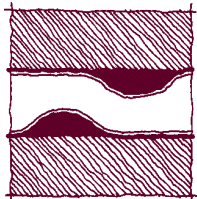
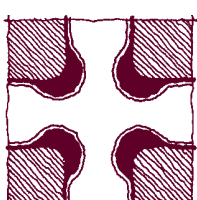
Common Types of Traffic Calming Methods
(Continued)

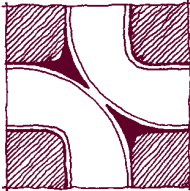
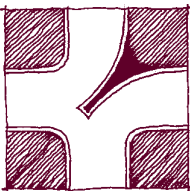
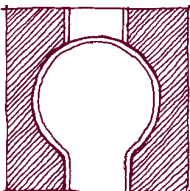
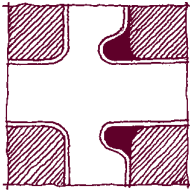
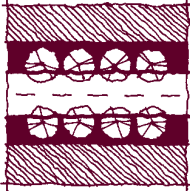
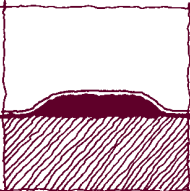

<i>Drawing</i>	<i>Technique</i>	<i>Description</i>
	Signs and Neighborhood Gateways	Signs such as “Residential Street,” “Local Access Only”, or monuments that identify neighborhood districts can be effective, especially when used conjunction with other techniques, including those listed above and others, such as pavement markings and textured warning strips.
	Special Paving	Alternative road surfaces, such as brick, colored concrete or special pavers, can be used at crossings, intersections, or along the sides of the street to break up the visual expanse of pavement and define areas of pedestrian travel.
	Speed Watch Programs	Citizens and organizations can utilize a radar device and electronic sign board to measure speeds of passing vehicles in their neighborhoods. Letters of warning can be sent to the registered owners of offending vehicles. These programs promote neighborhood

Table 56 (Continued)

For additional information related to the different types of traffic calming techniques, refer to the sources listed at the end of this section. Included on this list is *A Guidebook for Residential Traffic Management*, available from WSDOT, which provides comprehensive information about traffic management techniques in practices throughout the world today.

Traffic Calming Circles

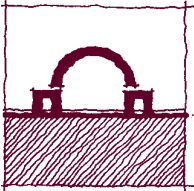
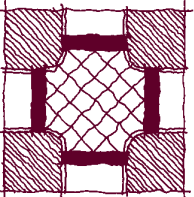
As discussed in Toolkit 6 — Intersections, there are many types of traffic circles. Larger traffic circles, such as rotaries and roundabouts, function primarily to improve traffic flow through the intersection. Smaller to intermediate circles, 3.0 to 6.1 meters (10

to 20 feet) are used to control speeds at the intersection of two local streets. These smaller to intermediate circles are commonly used for neighborhood traffic calming on local streets.

Traffic calming circles are very effective in reducing vehicle speeds and discouraging non-local trips through neighborhoods, which benefits pedestrians. Traffic calming circles create a condition where vehicles are forced to stop or significantly reduce their speed at the intersection, which allows better opportunities for pedestrians to cross.

A drawback of some traffic calming circle designs is that vehicles need to swing wide at the intersection to avoid the center barrier and vehicles may intrude into the pedestrian

crossing area if insufficient space is provided for the turning movement. A minimum of 4.0 meters (13 feet) of clearance between the circle edge and the crossing location is recommended when designing traffic circles.

Another drawback is that some drivers try to take the shortest path through the traffic calming circle and turn toward the left, rather than going all the way around the circle. This creates an unexpected movement to crossing pedestrians. For this reason it is best not to locate traffic circles at intersections where there are a high volume of left-turning movements.

Traffic circles are often landscaped and provide a nice amenity to the neighborhood. Sometimes local residents take on the responsibility of maintaining the circle and it becomes a neighborhood “p-patch.” Care must be taken to select landscaping that will not block views between motorists and pedestrians crossing on opposite legs of the intersection. Upward high branching trees are suggested, along with shrubs (as well as annuals and perennials) that do not exceed a height of 0.6 to 0.9 meters (2 to 3 feet).

Mountable curbs at the perimeter of the traffic circle are recommended to provide the ability for large vehicles, including emergency vehicles, to drive over the edge of the circle if they are having trouble making the turn around the island.

Figure 91 illustrates a variation of traffic circles and it is based on the traffic circle design successfully used throughout Seattle neighborhoods. For more information on traffic circle and roundabout design, refer to the list of resources at the end of this toolkit section.

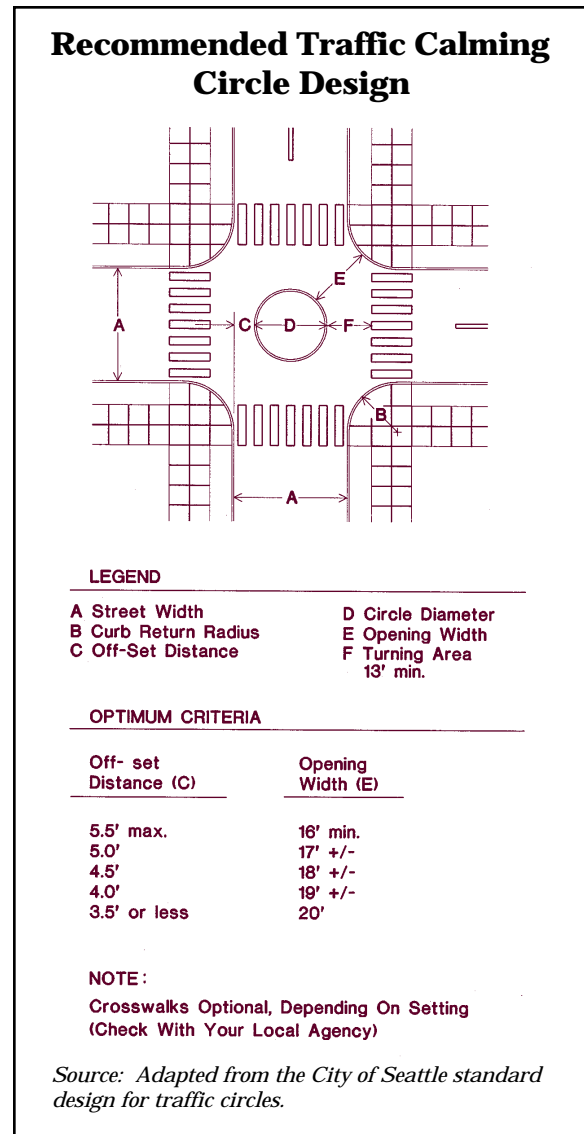

Figure 91

Narrow Streets

Narrowed streets that are either physically narrower or that create the perception that they are narrower are effective methods for calming traffic. Reduced street widths in residential and suburban areas are more commonly allowed by local jurisdictions. Narrow streets not only provide the benefit of traffic calming, but also help to create a more attractive and pedestrian friendly character

along the street. Narrow streets also reduce construction and maintenance costs.

Street trees lined on either side of the street narrow the driver's field of vision. When the driver's field of vision is narrowed, the automatic reaction is to slow down. On-street parking, separated walkways with planting strips, and bike lanes also narrow the look of a street. The use of contrasting pavement or texture in the bike lane or as a dividing strip at the edge of the road can further help to make the roadway appear narrower. Figure 92 illustrates an example of how a street lined with trees and bike lanes looks narrower than one identical in width without these elements.

Medians and Refuge Islands

The benefits medians and refuge islands provide for pedestrians and recommended design guidelines are discussed in Toolkit 6 — Intersections and Toolkit 7 — Crossings. Medians and refuge islands provide traffic calming because they help to narrow the field of vision of the approaching motorist, especially when they contain trees and landscaping (low growing shrubs or groundcover).

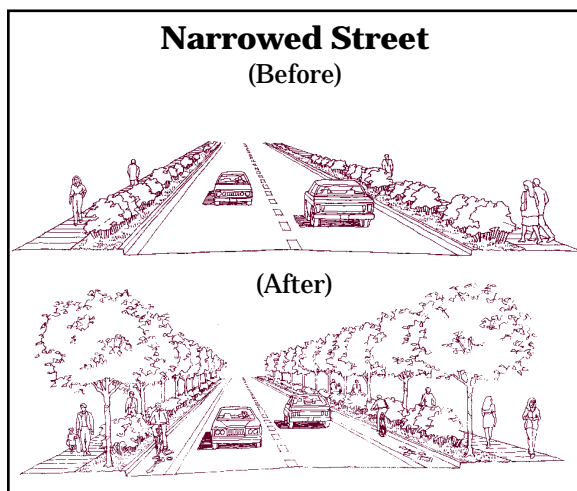

Figure 92

Chicanes

Chicanes are curb extensions or other features (such as landscape islands and on-street parking) that alternate from one side of the street to the other, where either one lane of traffic is fully closed at “pinch points” where one car has to wait for another to pass before proceeding, or partially closed and enough roadway width remains for two cars to pass. A study of the use of chicanes in Seattle in 1988 showed varying decreases in traffic volumes ranging from 6 percent to 48 percent on higher volume streets (Seattle Transportation Division, *Traffic Calming*, Hoyle). The study also found a significant reduction in vehicle speeds and concluded that speeds on neighboring streets continued to increase without chicanes.

Chicanes provide the advantage of not blocking emergency vehicle access and allowing local access opportunities. Drivers are more likely to violate chicanes, especially at intersections with low traffic volumes. Chicanes should be made visible with signs, painted curbs, landscaping, reflectors, and street lights. Figure 93 illustrates an example of chicanes used along a neighborhood street. On-street parking is not permitted at the ends of the street.

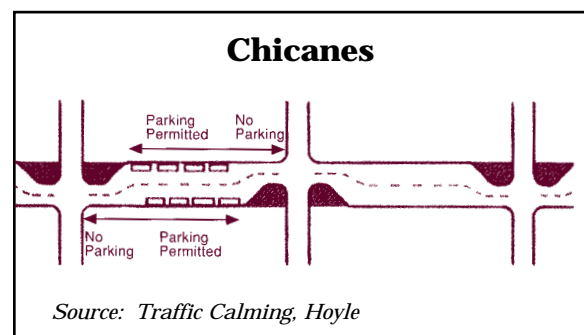

Figure 93

Curb Extensions and Bulb-Outs

Curb extensions and bulb-outs can be designed in a variety of ways. When placed at intersections and mid-block crossings, they provide the advantage of reducing the crossing width for pedestrians. Curb extensions are often used in conjunction with landscape treatments to enhance the street and buffer adjacent parking. They also help to more clearly identify mid-block crossing locations to both pedestrians and motorists.

In some cases, a curb extension or “choker” is used at intersections to create a one-way entry or exit point for that specific street segment. Autos are allowed to exit the street, but entrance occurs at side streets. Pedestrians and bicyclists are allowed to travel in both directions.

Figure 94 illustrates typical curb extension and bulb-out designs.

Diverters and Street Closures

Diagonal diverters close roads and eliminate through traffic, while providing access to the surrounding neighborhood. The diverter island provides an area for landscaping and aesthetic enhancement. The island also provides a crossing refuge area for pedestrians.

Full street closures eliminate all through traffic, improving the safety of the street by significantly reducing traffic volumes and speeds near the closure.

A disadvantage of full street closures and diagonal diverters is that they cut off emergency vehicle access unless another route can be provided. They also limit access opportunities for the affected residents. Through-traffic may transfer to other local

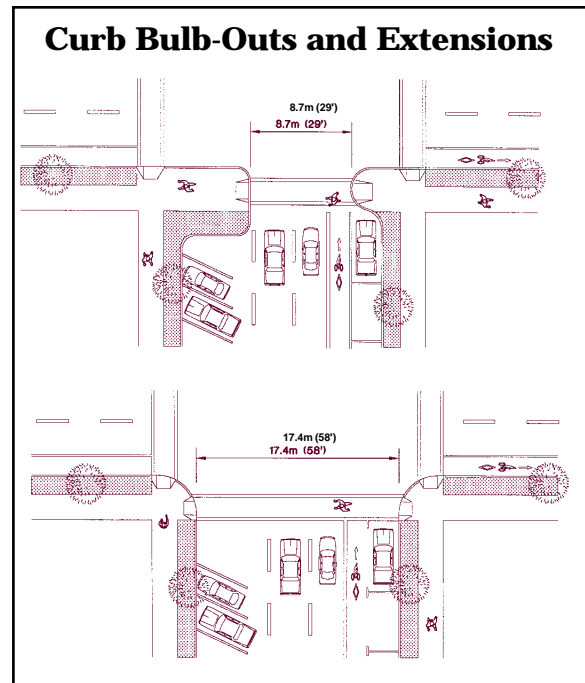

Figure 94

streets in the area if not managed. Another concern is that the closure of streets may contradict other transportation and land use planning goals that encourage an open grid system of streets.

Partial street closures reduce through-traffic in one direction and partially in the other. Traffic is diverted, while allowing for emergency vehicle and local resident access.

When streets are either fully or partially closed, it is always important to continue to provide pedestrian and bicycle access through the closed area.

Raised Intersections

Raised (or tabled) intersections provide the advantage of slowing vehicles at one of the most critical locations for pedestrian crossing activity. Raised intersections are often paved with contrasting material (stamped, scored, or colored concrete or unit pavers) to the



roadway and stand out visually to approaching motorists. The use of special paving also helps to delineate the pedestrian crossing area.

Raised intersections create an area clearly designated for pedestrians. Approaching motorists can see that the intersection is not a location designed for rapid, through-movement, which causes them to slow down and yield the right-of-way to pedestrians. Raised intersections are not appropriate for high speed thoroughfares and major arterials and collectors. Local requirements may prohibit their use under a variety of circumstances.

Raised intersections make it easier to meet the ADA requirements because the crosswalk is a natural extension of the sidewalk, with no change in grade. Raised intersections require special treatment, such as tactile warning strips or audible signals, to make them detectable to the visually-impaired.

Placement of drainage inlets is simplified at raised intersections, because surface water will drain away from the center of the intersection.

Changes in pavement color and texture at the intersection raise a motorist's awareness through increased visibility, noise, and vibration. Crossings constructed with special paving should use nonslip bricks or unit pavers. Scored or stamped and colored concrete surfaces can also be used, and are generally more durable over the long term than unit pavers, with more uniform joints and less chance of displacement. Special paving surfaces should be installed and maintained in a smooth, level, and clean condition. Care should be taken to ensure that grooves and joints are not so deep as to impact accessibility.

Speed Humps (Not Speed Bumps)

Speed humps are raised areas in the roadway that do not function as crossing areas, but that are designed similarly to raised crosswalks and speed tables. Speed humps are typically located on local or neighborhood collector streets with daily vehicle volumes greater than 300 vehicles per day but less than 3,000 vehicles per day. Well designed speed humps allow vehicles to proceed over the hump at the intended speed, usually 24 kph (15 mph) with minimal discomfort, but driving over the hump at higher speeds will rock the vehicle.

Speed humps are *not* speed bumps, which are smaller raised areas 0.3 to 0.9 meters (1 to 3 feet) wide. Speed bumps are not suitable for public roads. Speed humps are marked on the street as "Speed Bumps," by most jurisdictions because the term "bump" is more widely understood than "hump."

Many designs have been developed for speed humps. The Institute of Transportation Engineers (ITE) has recommended a parabolic speed hump that is based on a profile developed by the Transport and Road Research Laboratory in Great Britain. This design is illustrated in Figure 95 , and provides for vehicle speeds of 24 kph (15 mph) at the hump and 32 to 40 kph (20 to 25 mph) between properly spaced humps.

There are generally no accepted standards for signing and marking speed humps. It is desirable to install advance warning signs 30.5 meters (100 feet) in advance of speed humps. The City of Bellevue speed hump design, as well as signing and marking recommendations, are illustrated in Figure 96.

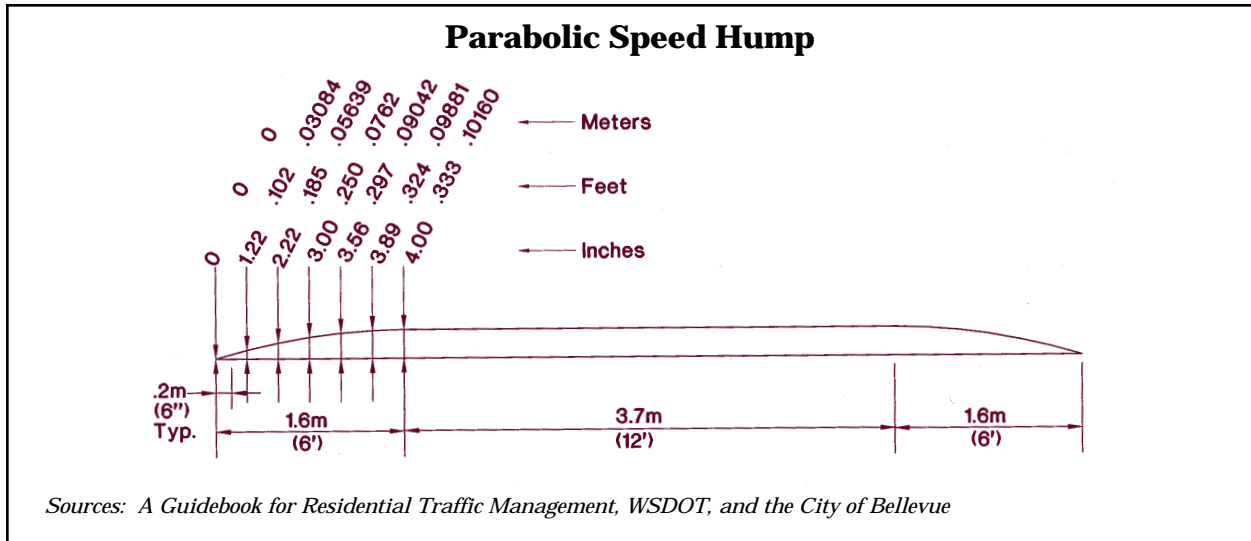

Figure 95

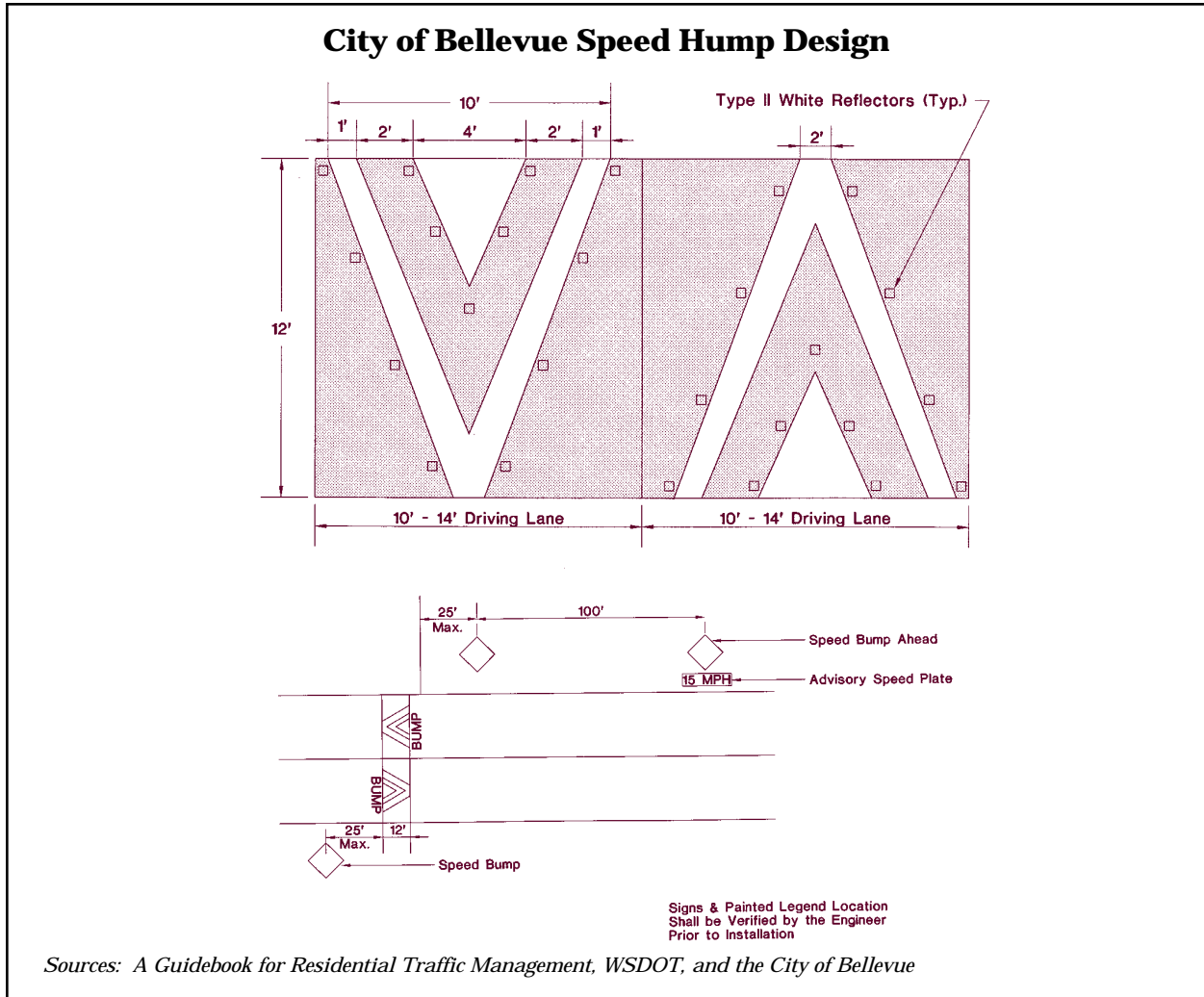

Figure 96

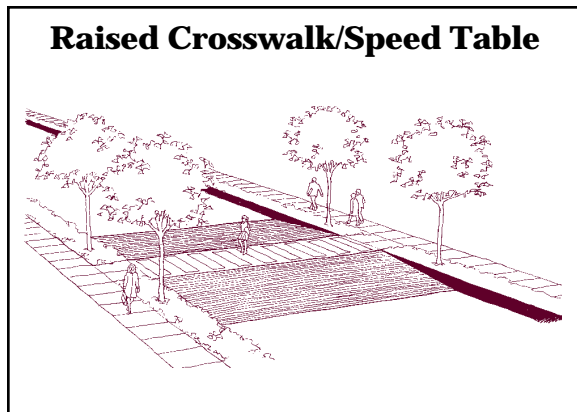

Figure 97

Raised Crosswalks/Speed Tables

Raised crosswalks are speed humps that are marked as designated crossings. They may be wider than typical speed hump designs. Raised crosswalks or speed tables are appropriate at mid-block locations on local streets, some subcollectors and collector roads, and in other locations like at airport drop-off and pickup zones, shopping centers, and campuses. Raised crosswalks are typically marked with high visibility crosswalk designs or may be surfaced with special paving (see Raised Intersections). Figure 97 illustrates a typical raised crosswalk.

Gateways

Gateway treatments generally encompass a wide variety of techniques that provide neighborhood identification, such as signs, monuments, landscaping, special paving, narrowed entrances, and other elements. These enhancements help to provide an indication to motorists that they are entering a neighborhood area from an arterial road or other type of street where traffic was moving at higher speeds.

Other Sources of Information

The following sources of information are recommended for traffic calming. Please see the Resource Guide included at the end of this guidebook for complete bibliography information.

A Guidebook for Residential Traffic Management, Final Report, Washington State Department of Transportation

A Sampler of Neighborhood Traffic Calming Efforts, Chris Leman

"A Toolbox Approach to Residential Traffic Management," Joseph Savage and R. David MacDonald

Accommodating the Pedestrian, Adapting Towns and Neighborhoods for Walking and Bicycling, Richard K. Untermann

"Boulder Brings Back the Neighborhood Street," John Fernandez

City Comforts, How to Build An Urban Village, David Sucher

Design and Safety of Pedestrian Facilities, A Proposed Recommended Practice of the Institute of Transportation Engineers, ITE Technical Council Committee 5A-5

Florida Pedestrian Planning and Design Guidelines, University of North Carolina

Great Streets, Allan B. Jacobs

Handbook for Walkable Communities, Washington State Pedestrian Facilities Planning and Design Courses, Dan Burden and Michael Wallwork, PE

King County Neighborhood Traffic Control Demonstration Program, The KJSA Team

Livable Neighborhoods: Rethinking Residential Streets, American Public Works Association and the University of Wisconsin-Madison

Livable Streets, Donald Appleyard

Portland Pedestrian Crossing Toolbox for Pedestrian Program Bureau of Transportation Engineering and Development, Charles V. Zegeer

Preparing Your Own Design Guidelines, A Handbook for Seattle' Neighborhoods, City of Seattle Department of Construction and Land Use and Planning Department

Reclaiming Our Streets, Traffic Solutions, Safer Streets, More Livable Neighborhoods, Community Action Plan To Calm Neighborhood Traffic, Reclaiming Our Streets Task Force, City of Portland Bureau of Traffic Management

Redevelopment for Livable Communities, Washington State Energy Office, the Washington State Department of Transportation, the Department of Ecology, and the Energy Outreach Center

Residential Streets, American Society of Civil Engineers

Traditional Neighborhood Development: Will the Traffic Work? Walter Kulash

Traffic Calming, Cynthia L. Hoyle

Traffic Calming, A Guide to Street Sharing, Michael J. Wallwork, PE

"Traffic Calming — An Overview," Walter Kulash

Traffic Calming — The Solution to Urban Traffic and a New Vision for Neighborhood Livability, Citizens Advocating Responsible Transportation, Ashgrove, Queensland, Australia

Pedestrian Access to Transit

This Toolkit Section Addresses:

- *Transit Compatible Design*
- *Improving Transit Facilities for Pedestrians*
- *Transit Stops and Bus Pullouts*
- *Transit Centers*
- *Park-and-Ride Facilities*
- *Transit Malls*
- *Coordination Between Agencies*
- *Other Sources of Information*



Transit and walking are alternative modes of transportation that are complementary and supportive to each other.

Transit includes several types of transportation modes, including public bus services, commuter and light rail lines, ferries, van pools, subways, and monorails. Expanding access to transit and improving transit facilities are complementary to promoting pedestrian travel as an alternative transportation mode. Transit compatible planning and design and efficient transit service are supportive of one another in thriving communities.

This section discusses design practices that promote and enhance transit access for pedestrians and improve conditions at transit facilities, encouraging both transit use and higher levels of walking. The focus of this section is not on overall design of transit facilities, but rather on specific design of features and facilities for pedestrians accessing transit facilities. Several other useful documents related to transit facility design are available for reference. Refer to the list at the end of this toolkit.

Many of the design guidelines suggested in this section are a summary of varying practices. Consult with local transit agencies to verify local requirements for boarding pads, bus stop locations, and other important design criteria that may be unique to individual transit authorities.



Enhancing pedestrian access to transit increases transit use.

Transit Compatible Design

Planning and design for areas where transit service is available, or may become available in the future, should provide transit compatible features, as illustrated in Figure 98. Refer to *A Guide to Land Use and Public Transportation, Volume II: Applying the Concepts* for other transit compatible planning and design recommendations.

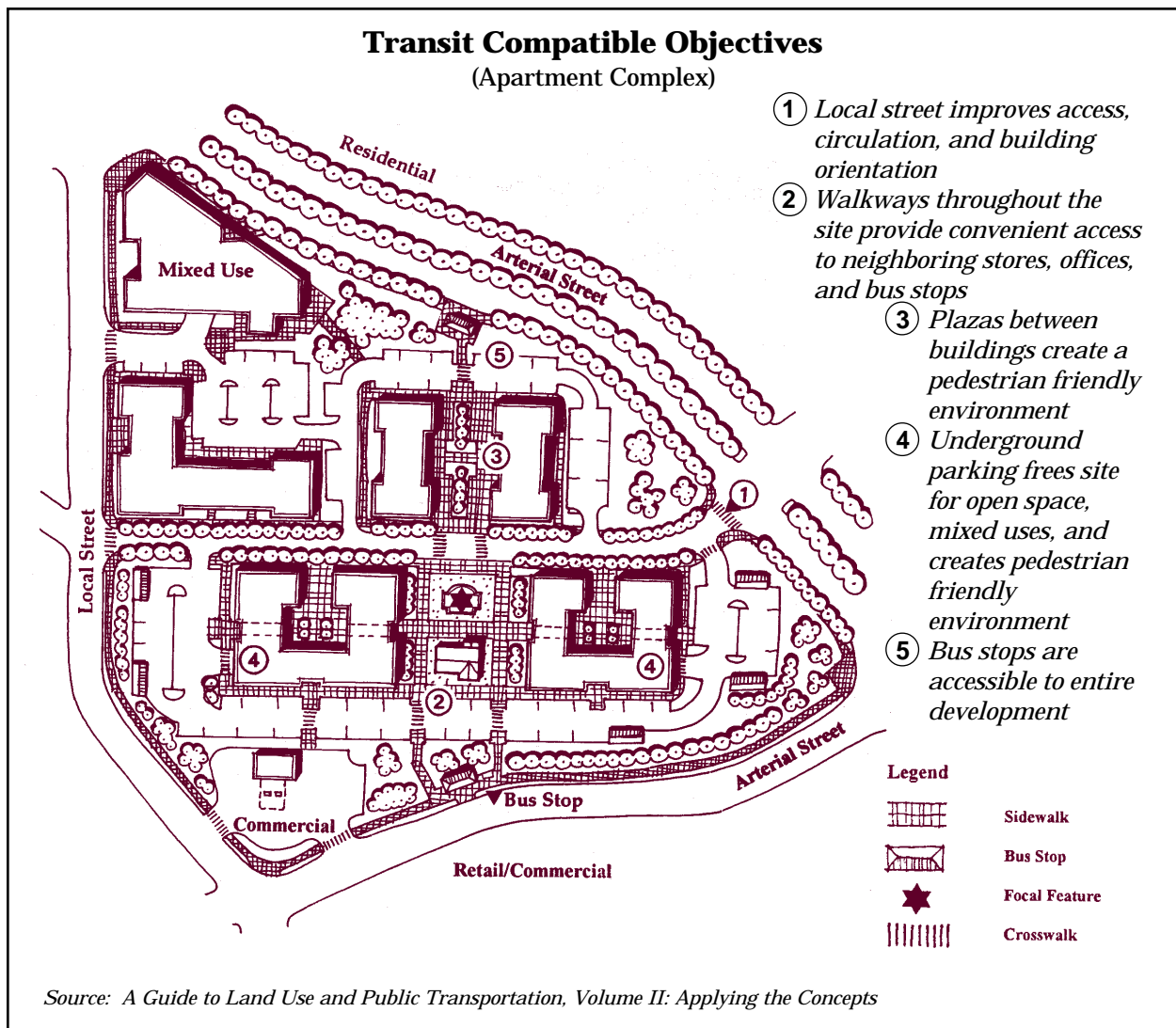

Figure 98

Improving Transit Facilities for Pedestrians

The success of transit as a mode of transportation is highly dependent on pedestrian access. People with disabilities (including people who use wheelchairs or are sight impaired) often rely on transit as their primary source of transportation, and transit facilities need to be designed to meet their needs. (Refer to the section called About Pedestrians for a discussion on the spatial needs for pedestrians, and Toolkit 2 — Accessibility.) Some important design guidelines can be followed to encourage and improve access to transit facilities for pedestrian riders:

- Provide sidewalks, walkways, or informal paths on streets with bus routes that lead to transit stops
- Design sidewalks that access transit with a minimum of 1.8 meters (6 feet) in width, enabling two adults to walk comfortably side-by-side. In urban areas, where street furnishings, parking meters, sign posts, and other elements clutter the sidewalk, the desirable minimum width is 3 meters (10 feet).
- Provide a 2.7-meter (9-foot) long by 1.5-meter (5-foot) wide landing pad at bus entrances and exits (measured from the direction of getting on or off the bus), as required by the ADA for some bus stop locations. It may be desirable to build a continuous strip of 2.4-meter (8-foot) sidewalk or shoulder along the entire length of the bus stop, rather than to try and predict where in the sidewalk the landings should be. The buses may not stop in the exact location each time. Refer to Figure 99

for an illustration of a widened bus loading area. Figure 100 illustrates a typical bus stop cross-section.

- Encourage transit use by providing shortcuts that reduce the distance a pedestrian must walk. Bridges over streams, paths through parks and neighborhoods, and walkways that connect to dead-end streets can provide expanded access opportunities for pedestrians.

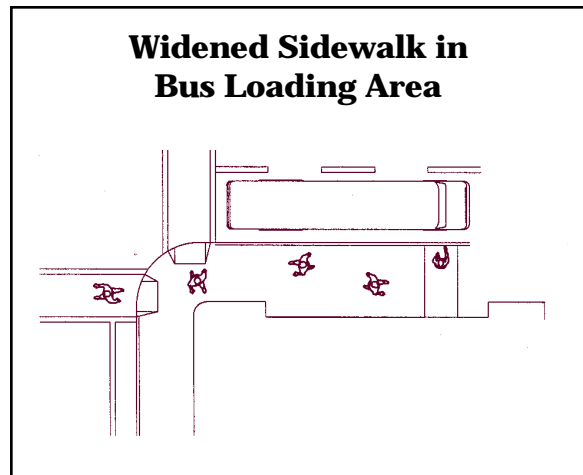

Figure 99

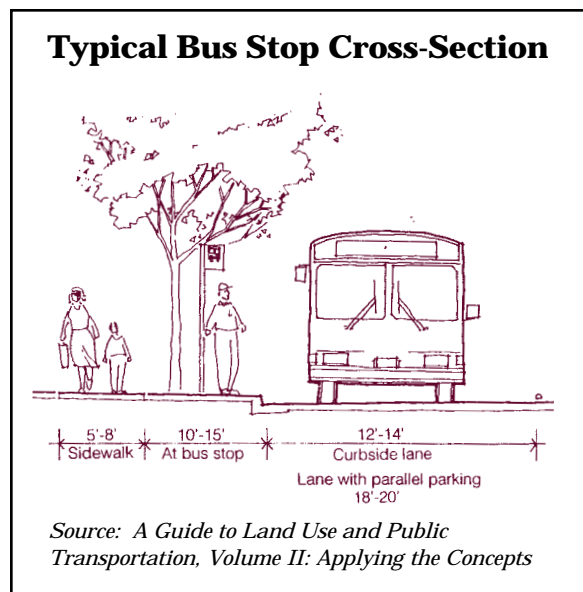

Figure 100

Source: *A Guide to Land Use and Public Transportation, Volume II: Applying the Concepts*

- Provide well-lit access ways to transit facilities, since transit riders often commute to work or school in early morning and late afternoon and evening hours.
- Keep pedestrian signals and other traffic control devices operational and set with timings that allow pedestrians to comfortably cross streets to reach transit stations and bus stops.
- Provide separate spaces for those waiting, passing through, transferring between buses, and queuing to board and deboard to improve pedestrian mobility and transit function.
- Locate bus stops to discourage crossing of streets at undesirable locations.
- Create space directly adjacent to bus loading areas that is free of all street level obstacles. Street furnishings (except for bus stop signs) such as benches, pay phones, light posts, shelters, kiosks, and garbage receptacles should be set back a minimum of 2.4 meters (8 feet) from the curb where adequate space is available. Where space is



Installing street furnishings set back from the curb increases pedestrian mobility and visibility.

not available, the lateral clearance required by the ADA is 0.9 meters (3 feet).

- Maintain open sight lines between the bus operator's view and the passenger waiting and loading areas. Shelters should be constructed with windows and clear materials to provide a view of the waiting passengers inside. The recommended minimum for height clearance for all signs in the bus stop zone is 2.1 meters (7 feet) from the bottom of the sign to ground level. Overhanging tree branches need to be at least 2.4 meters (8 feet) from the ground to avoid signing obstruction or interference with mirrors on the buses.
- Provide open zones that promote visibility of users and visibility for users to increase their perception of personal security.
- Provide shelters and covered structures where feasible to protect passenger waiting areas from wind and precipitation (see Figure 101).
- Provide accessibility to people with disabilities with curb cuts, ramps, and

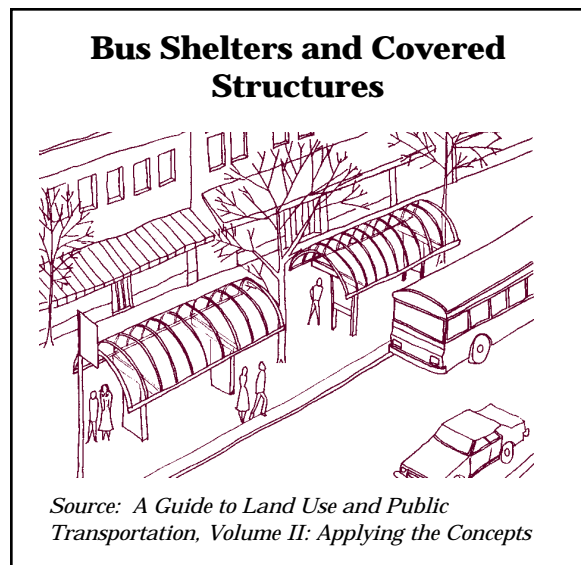

Source: *A Guide to Land Use and Public Transportation, Volume II: Applying the Concepts*

Figure 101



clearly defined and delineated pedestrian space.

- Reduce risks of slipping and falling by providing paving surfaces with good traction. Pavement texture and color can also be used to communicate function and spatial relationships for the visually impaired.
- Install street furniture that is durable and vandal resistant.
- Consider aesthetics and maintenance requirements in the initial design phase, rather than as an afterthought.

Some relatively low-cost improvements that can increase pedestrian access to transit are listed in Table 57.

Low Cost Improvements to Increase Pedestrian Access to Transit
<ul style="list-style-type: none"> • Pavement markings where sidewalks or other pedestrian facilities do not exist • Marked crosswalks • Removal of sidewalk obstructions • Changes in signal phasing at intersections and crossings near stations and bus stops

Table 57

Transit Stops and Bus Pullouts

Transit stops and bus pullouts or zones provide designated space for loading or unloading passengers. A zone accommodating

one bus is normally from 24.4 to 48.8 meters (80 to 160 feet) in length, and longer in business districts with high levels of use. Bus stops can be as simple as a sign and a pullout area, designated space at the curb, or shoulder for the bus to stop. Or, they may include other facilities, such as shelters, benches, and other furnishings.

There are three choices for location of bus stops — near-side, far-side, and mid-block. Near-side stops are located on the approaching side of an intersection in relation to the direction of travel. Far-side stops are located on the departing side. Mid-block stops are not close enough to an intersection to be affected by the intersection. Far-side stops are generally more desirable than near-side stops from the perspective of the pedestrian, but near-side stops can be successfully designed to adequately accommodate pedestrians.

The following considerations for pedestrians should be made when designing bus stops and pullouts:

- Provide a minimum 1.2-meter (4-foot) wide clearance zone from the curb so that opening bus doors are not blocked by street furnishings, sign posts, landscaping, or other obstructions.
- Provide 2.7 meters (9 feet) of clearance from the curb for wheelchair lift operation; 1.2 meters (4 feet) for the lift to extend and 1.2 meters (4 feet) for the wheelchair to maneuver beyond the lift. The ADA requires a minimum width of 1 meter (3 feet) for accessible paths of travel. Design bus stops to accommodate wheelchair lifts. Only as a last resort should a zone or stop be inaccessible.



Pedestrian Access to Transit

- Provide open sight lines and avoid placing shelters, furnishings, and vegetation that may obstruct driver and waiting passenger views, as discussed previously.
- Shelters should be well-lit and constructed of materials that do not obstruct views out of or into the shelter.
- Sidewalks should be provided within designated bus zones with a landing area for wheelchair access to transit services.
- Transit riders need to be able to cross the road safely at transit stops. On a typical two-way street, with residences and development on both sides, half the riders will need to cross the road when boarding or exiting the bus. Mid-block crossing facilities should be provided at mid-block bus stop locations. See Toolkit 7 — Crossings for discussion on mid-block crossings.
- Curb heights should never be higher than the height of the bus step to prevent falls during passenger boarding and departing. Older buses tend to have a bottom step that is 0.4 to 0.5 meters (14 to 18 inches) above the roadway. Newer buses can have bottom steps as low as 0.3 meters (11 inches) above the roadway.
- On streets with parallel parking, near-side bus stops can benefit from elongated curb bulb-outs (or neck-downs) that provide passengers adequate area to board or exit the bus without having to step into the street or the stream of pedestrian travel on the adjacent sidewalk. With this facility, buses are able to pull up directly adjacent to the curb.
- Bus stop design should avoid conflicts with other types of uses. For example, bus stops should not interrupt bike lanes, and waiting areas and shelters should be provided to the side of the walkway so that pedestrians can pass passengers waiting to board.
- When there is a planting strip directly adjacent to the curb, provide a sidewalk slab that extends from the existing sidewalk to the curb so that passengers do not have to cross wet grass or mud during inclement weather.
- Avoid locating bus stops where there are curbs of varying heights.
- Strategically locate bus stops to minimize crosswalk movements of transferring passengers if transfer movements between bus routes are heavy. For example, locate bus stops on the same corner of an intersection so users are not required to cross the street (see Figure 102).
- All transit stops should be easy to reach by walkways.
- Transit stops should include sheltered, visible, and comfortable seating areas and waiting spaces, set back from the walkway.

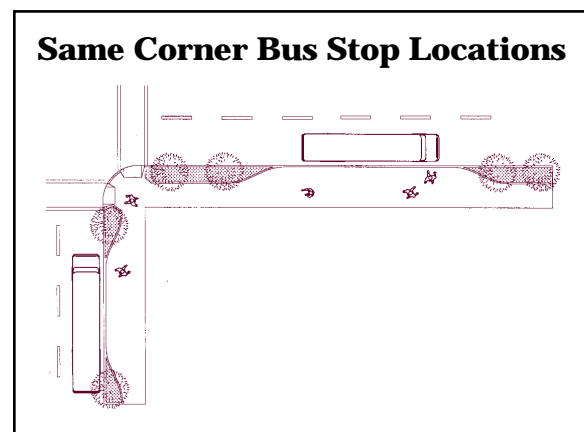

Figure 102

- Bus stops should provide shelters for protection from weather and secure waiting place for transit riders.
- Bus pullout locations are often warranted where there are heavy traffic conditions. When pullouts are to be located near intersections, a far-side location is preferred. The needs of the passengers boarding and exiting the bus should not conflict with the needs of pedestrians and bicyclists moving through the area. Curb bulb-outs at the nearby intersection help pedestrian crossing movements, prevent motorists from entering the bus pullout area, and reduce conflicts with bicyclists traveling through. Pullouts should be designed to meet roadway conditions and bus characteristics. Configurations of pullouts should allow buses to pull up directly adjacent to the curb.

Transit Centers

Transit centers provide an area for buses on two or more routes to come together at the same time for transferring riders, or as points of origin and destination. Transit centers can be sited to optimize pedestrian access to major activity centers, such as shopping centers and college campuses. Transit centers can also promote transfer connections between different transportation systems. Because they are highly visible facilities within the community, transit centers help increase public awareness of the availability of transit service. Both off-street and on-street transit centers can be developed, depending on the space requirements, street traffic volumes, passengers within walking distance, and other factors.

Transit centers function best when designed to meet the demands of peak user levels. Platform space needs to be adequate to

accommodate all pedestrians, including those who are waiting, queueing, or simply walking up and down the sidewalk or platform. A common rule of thumb for determining space requirements for platform areas is 3 square meters (10 square feet) per person, using the peak pedestrian volume anticipated.

The most important element of design for transit centers is minimizing circulation conflicts between buses, pedestrians, and autos. Pavement delineation with texture, color, striping, or other means can help identify spaces that are for exclusive use by pedestrians. Buffering techniques with planter boxes, street trees, furnishings, or other circulation design elements can be used to provide separation between pedestrians and automobiles wherever possible.

Park-and-Ride Facilities

In addition to the general conditions recommended for all transit facilities described previously, park-and-ride lots that function well for pedestrians generally include:



Transit centers help increase public awareness of the availability of transit service.



Pedestrian Access to Transit

- At least one accessible route of travel, 1 meter (3 feet) wide safely delineated over the entire site
- Sidewalks next to curb-side parking lanes and to all loading zones
- Minimum 1.8-meter (6-foot) wide sidewalks for two-way pedestrian travel, and greater width if feasible; the recommended minimum width of sidewalks adjacent to a bus or taxi loading zone is 3.7 meters (12 feet), with 2.4 meters (8 feet) of unobstructed space next to the curb
- A maximum walking distance of 244 meters (800 feet) from the car to the bus loading zone
- Security lighting
- Public pay phones

In addition, other desirable features can include drinking fountains and restrooms where feasible and justified.

Transit Malls

Transit malls are created by removing automobile and truck traffic on sections of existing street systems, usually on principal streets within the urban network. Only buses, taxis, and light rail are allowed to access the transit mall area. Parking is prohibited and walks are widened to accommodate higher volumes of pedestrians. Streetscape improvements, including special pavement, public art and sculpture pieces, benches, and other furnishings are typically found at a successful transit mall. Transit malls function well as social gathering spaces and can become a good location for art exhibits and a variety of downtown activities,

as long as these activities do not interfere with the principal purpose of the facility — convenient access to transit.

A transit mall serves as a linear linkage system between activities along its route, including housing, retail, office, hotels, and entertainment. A transit mall may also be an area of concentrated transit facilities with high volumes of transferring or transit riders being picked up and dropped off. Transit malls typically function best in places where there is a diversity of uses (for example, in retail districts or downtown cores) and with a significant ridership source nearby, such as employment centers, college campuses, and sports stadiums. Several elements can encourage use of transit malls by pedestrians and keep them looking attractive:

- Shaded, sheltered areas to sit and read or walk around
- A well-planned layout with adequate clearances for accessibility and sufficient space for high volumes of pedestrians
- Security through adequate lighting, clear sight lines, visibility, and regular patrols



Transit malls can accommodate higher volumes of pedestrians.



- Aesthetically pleasing and interesting things to look at, such as artwork, colorful planters, and fountains
- Quality paving materials and street furnishings
- Litter receptacles and cigarette ash cans

Restrooms and drinking fountains improve user comfort but are often too costly to include.

Coordination Between Agencies

Coordination between transit agencies, local jurisdictions, and transportation system planners and designers is essential when planning and designing pedestrian facilities for access to transit. Often, transit stops are located without the benefit of crosswalks or sidewalks nearby. Land use planning efforts sometimes do not consider ways to support transit use in communities. Communication and coordinated reviews between transit agency staff and local planners and engineers should occur during the beginning stages of new projects.

Other Sources of Information

The following sources of information are recommended for pedestrian access to transit. Please see the Resource Guide included at the end of this guidebook for complete bibliography information.

A Guide to Land Use and Public Transportation, The Snohomish County Transportation Authority

A Guide to Land Use and Public Transportation, Volume II: Applying the Concepts, The Snohomish County Transportation Authority

Accommodating the Pedestrian, Adapting Towns and Neighborhoods for Walking and Bicycling, Richard K. Untermann

Bellevue Transit Neighborhood Links Project, Otak, Inc.

Design and Safety of Pedestrian Facilities, A Proposed Recommended Practice of the Institute of Transportation Engineers, ITE Technical Council Committee 5A-5

Developing Your Center: A Step-by-Step Approach, Puget Sound Regional Council

Linking Bicycle/Pedestrian Facilities With Transit, M. Replogle and H. Parcells

Metro Transportation Facility Design Guidelines, Municipality of Metropolitan Seattle

Non-Motorized Access to Transit, Final Report, Wilbur Smith Associates

Non-Motorized Access to Transit, Technical Appendices, Wilbur Smith Associates

Pedestrian Malls, Streetscapes, and Urban Spaces, Harvey M. Rubenstein

Planning and Design for Transit, Tri-County Metropolitan Transportation District of Oregon

Using GIS for Transit Pedestrian Access Analysis, Orange County Transportation Authority Transit Programs Department

Site Design for Pedestrians

This Toolkit Section Addresses:

- *Thinking About Pedestrians as Part of Site Development*
- *Pedestrian Friendly Site Design*
- *Walkways and Accessible Routes*
- *Site Access and Driveway Design*
- *On-Site Circulation and Parking*
- *Building Location and Design*
- *Landscaping and Furnishings*
- *Ramps, Stairways, and Steps*
- *Sites Used Exclusively by Pedestrians*
- *Strategy for Increasing Pedestrian Travel — Mixed-Use Site Development*
- *Other Sources of Information*

Good site design accomplishes many important objectives related to pedestrians, including safer conditions, more convenient access, and increased pedestrian travel. When sites are designed with the pedestrian in mind at the onset, rather than as an afterthought, a more pedestrian friendly environment can be created. Pedestrians can easily tell whether or not their needs are being adequately considered at the businesses, shopping centers, community buildings, and other sites they frequent.

This toolkit section provides site design and development recommendations intended to make designers of private and public sites more aware of the needs of pedestrians. When pedestrian conditions are improved, pedestrian travel and activity in the area increases. Well designed sites that invite pedestrians and provide convenient facilities for them are also often successful businesses and vital areas within the community.



Sites should be designed to be accessible, safe, and pedestrian friendly.

Thinking About Pedestrians as Part of Site Development

Integrating pedestrians into site development is important. Increased pedestrian activity can be beneficial to business and can improve the safety and character of the community. Often, site development is oriented more toward creating convenient and efficient access and circulation for motor vehicles, rather than pedestrians. In order to fully integrate pedestrians into the overall transportation system, all places used by pedestrians need to be designed for their safety, convenience, and comfort, not just public rights-of-way.

What can be done to ensure that pedestrians are considered and planned for as part of all site development in our communities? To begin with, all development, public and private, should be required to include pedestrian facilities. Cities and counties should adopt ordinances and code requirements that encourage pedestrian friendly site design and development.

Perhaps one of the most important things that can be done to consider pedestrians in site design and development is for design professionals and developers to be more conscious of pedestrian needs at the onset of the planning and design process, rather than as an afterthought. Information provided in this toolkit addresses how to design several site elements with pedestrians in mind. This design guidance can be applied as appropriate to all types of sites, including office buildings, shopping centers, and multifamily developments, and other areas. (Refer to the discussion at the end of this toolkit for information related to sites used exclusively

by pedestrians and mixed use development as a strategy to increase pedestrian travel.)

Pedestrian Friendly Site Design

Designing sites to meet the needs of pedestrians doesn't have to be complicated. A simple approach can help designers envision a good pedestrian environment.

When reviewing a site for the first time, designers and developers should consider the point of view of a pedestrian walking through the site. There are several helpful questions designers can ask themselves at the beginning of the site design process.

Pedestrian Friendly Site Design Checklist

- Delineated walkways through parking lots
- Connections to neighborhoods and surrounding areas
- Easy to identify building entrances and building frontages located along streets rather than across parking lots
- Convenient and safe access to transit and adjacent sidewalks
- Alignment of walkways for convenience and reduced travel distances
- Accessible routes of travel to and from the site, as well as throughout the site
- No barriers (walls, ditches, landscaping, or roads without safe crossings) to pedestrian travel

Table 58

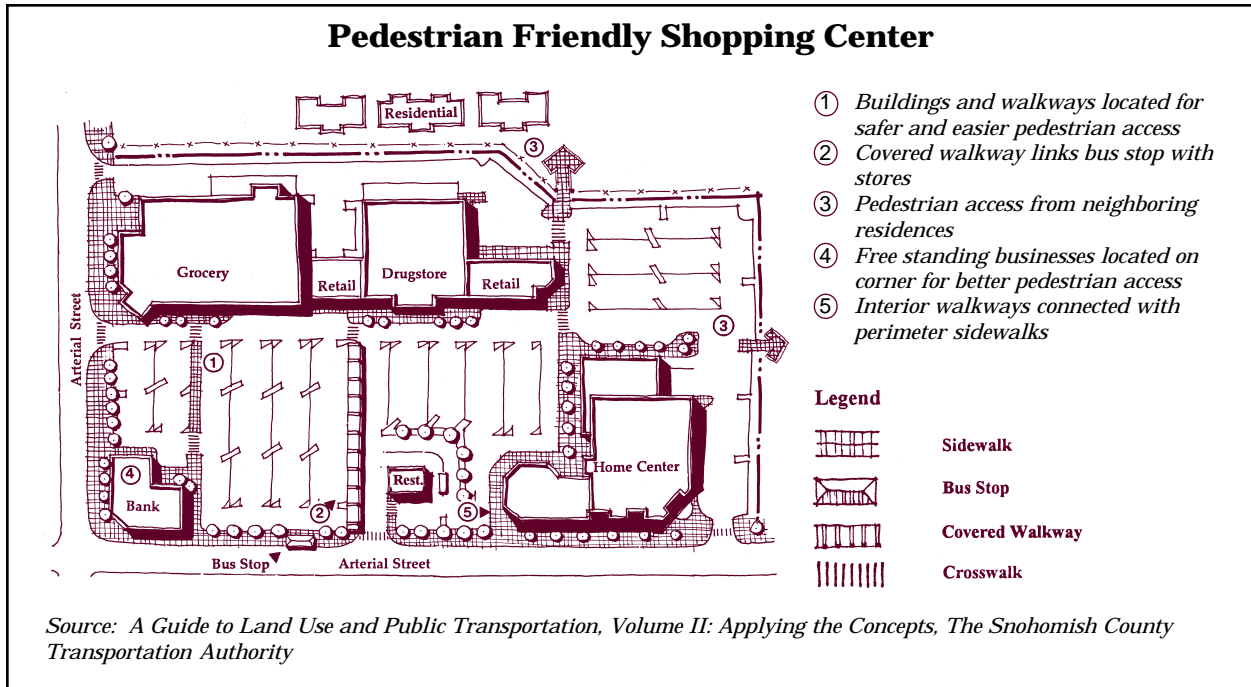

Figure 103

By considering these questions, the needs of pedestrians will be addressed as a basic premise of the overall site design process. Site planners and designers can begin to consider how various site elements can be specifically designed to improve conditions for pedestrians. There are many ways to make sites more friendly and accessible to pedestrians.

Table 58 provides an overview of some basic site design solutions that improve conditions for pedestrians. These solutions and other design recommendations related to various site elements are described in more detail over the next several pages. Figure 103 illustrates a good example of pedestrian friendly site design.

Walkways and Accessible Routes

Layout of walkways as part of site design is a key ingredient in making the site efficient for

pedestrian travel. The directions pedestrians will travel on sites in sometimes difficult to predict. Pedestrians will walk along routes that are the most convenient and direct to their destinations.

In urban areas and on sites where the priority for pedestrians is efficient access to and from buildings, parking, bus stops, and other site elements, walkways should be aligned along the most direct routes. Meandering walkways may look nice in certain settings, but are not the most efficient way of getting people from one place to another. People may not use a walkway if it does not provide the most direct route, especially during times of inclement weather or when they are in a hurry (on the way to work or class).

The Americans with Disabilities Act design guidelines require all sites to provide an accessible route of travel between accessible site elements such as parking areas, buildings, transit stops, perimeter sidewalks,

and other facilities. An accessible route is a clear level walkway that provides access for all pedestrians, including people with disabilities. Specific design requirements related to accessible routes of travel are provided in Toolkit Section 2 — Accessibility.

Figure 104 illustrates a building entrance directly accessible from the street.

Other walkway design treatments that can help to improve conditions for pedestrians include:

- Covered walkways and shelters increase pedestrian comfort and provide protection from weather
- Well illuminated walkways and corridors increase pedestrian security
- Raised walkways through parking areas (with curb cuts to provide accessibility) to avoid the need for “puddle jumping” during

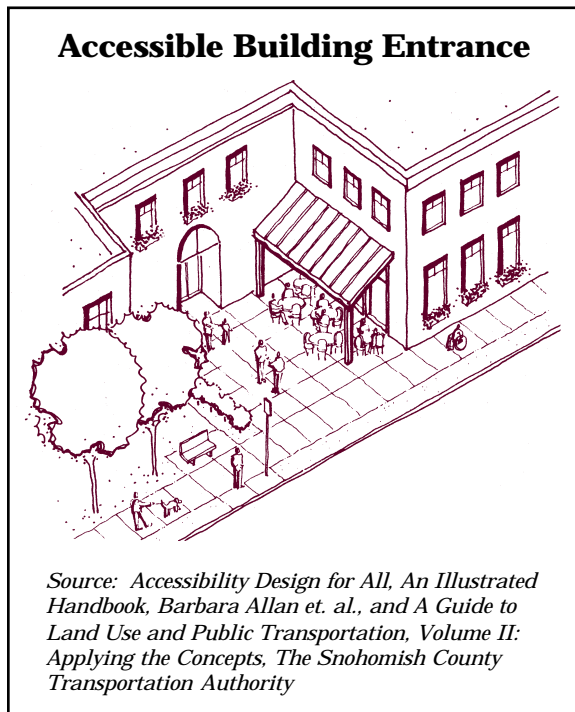

Figure 104

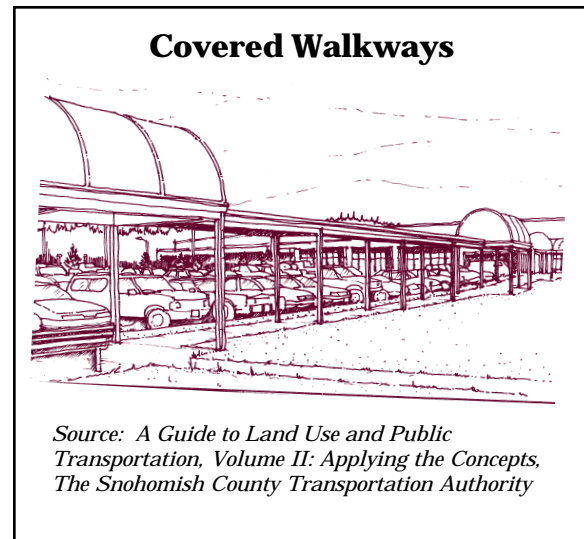

Figure 105

wet weather, and to more clearly define the pedestrian travel way (see Figure 105)

For more information related to walkway and pathway design, including dimensional guidelines, suggested surfacing materials, and other treatments, refer to Toolkit 4 — Trails and Pathways and Toolkit 5 — Sidewalks and Walkways.

Site Access and Driveway Design

Much can be done through access management and driveway design to improve pedestrian mobility and safety. Access management suggestions include:

- Limit the quantity and frequency of driveway access points and entrances to sites from streets to minimize interruption of pedestrian travel on adjacent sidewalks and walkways.
- Design sites so that adjacent properties can share access points where possible.

- Separate pedestrian and vehicle access to the site to minimize conflicts.
- Design emergency vehicle access to allow quick access and minimum conflict with pedestrians.

For more discussion related to access management techniques and benefits, refer to Toolkit 5 — Sidewalks and Walkways.

Driveways can be designed or retrofit so that they are easier for pedestrians to cross. Generally, the narrower the driveway width, the better for pedestrians. The shorter the crossing distance, the less likelihood of a conflict with a motor vehicle. The provision of clear sight lines between the pedestrian and the motorist pulling out of or into the driveway is very important.

Driveways that provide access to businesses, offices, or other commercial buildings can be built as conventional driveways or with designs that resemble street intersections (with right-in/right-out access control). For pedestrian safety and comfort, the conventional driveway design is more desirable, because motorists are forced to slow

down when turning into the driveway and the pedestrian right-of-way is more clearly established. Most residential driveways are designed in the conventional style.

Figure 106 illustrates three different driveway designs commonly being constructed. The least desirable of the three is the first design, which shows a very wide driveway with no refuge for pedestrians and undelineated crossing area. The driveway is designed to resemble a street intersection, which may encourage higher speed turns and discourage stopping for pedestrians since their right-of-way is not clearly delineated. In this design, the movement of the vehicle clearly takes priority over crossing pedestrians.

The second design (center drawing) is more desirable and is suggested for commercial driveways when it is not feasible to provide a conventional driveway apron design. The second design still treats the driveway like a street intersection, but it limits the driveway width to two lanes and provides a refuge island in the middle for crossing pedestrians. One additional element that would make this

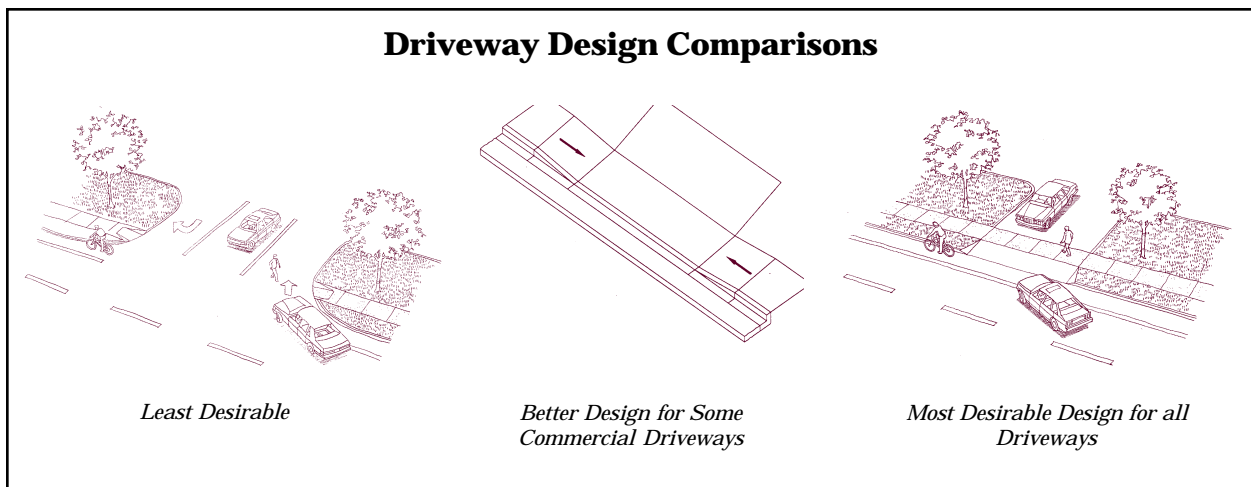

Figure 106

design better would be if the pedestrian travel way across the lanes were striped.

The third drawing (on the right) is the most desirable design. This design provides a delineated walkway across the driveway neck. In this conventional driveway design the pedestrian travel way is clear to the driver, the crossing distance is narrower, and the walkway stays at a constant grade.

Sidewalks that cross driveways and alleys can be problematic if sight distance is limited by adjacent buildings, landscaping, or other elements. Often drivers pulling into or out of the driveways are concentrating on the flow of vehicular traffic and may not notice oncoming pedestrians. Several measures can be applied to improve pedestrian visibility and make these crossings easier for pedestrians:



Site access should be well delineated to minimize conflict between pedestrians and vehicles.

- Unit pavers or colored pavement bands in the sidewalks prior to driveway entrances to provide a visual and tactile forewarning of the upcoming driveway crossing, or an alternative texture or pavement color across the entire pedestrian travel way at the driveway or alley access point to help motorists identify a pedestrian crossing zone
- Signs located to the side of the pedestrian travel way to identify upcoming driveways, and alleys
- Stop signs at an access point used by multiple drivers
- Curb stops at the access point to keep the front of the vehicle from protruding onto the sidewalk.
- Auditory warnings can be provided when vehicles are entering and exiting (often used in downtown areas where vehicles are exiting from parking garages)
- Mirrors placed in strategic locations so exiting drivers can see approaching pedestrians (Mirrors need to be placed carefully to avoid glare and obstruction to pedestrian travel.)
- Planting buffers that separate the walkway from the street allow some extra space

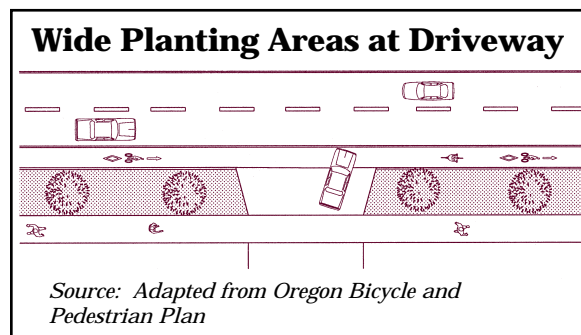

Figure 107

between pedestrians crossing the driveway and vehicles pulling into the driveway; they also provide room for the driveway apron to ramp up before the walkway, creating a more constant grade on the walkway (rather than dipping up and down at each driveway cut)

Wider planting areas at the perimeter of sites provide space for vehicles pulling out of driveways, eliminating the problem of blocking the sidewalk used by pedestrians (see Figure 107.) Note that when trees are planted in planting buffers near driveways, they should be placed to avoid affecting sight distance and upward branching species should be selected. Typically, tree trunks don't create a sight obstruction because drivers can pull up or back a few inches to see around them. It is important to ensure that any landscaping placed within proximity to driveways does not block visibility. (See Toolkit 5 — Sidewalks and Walkways for more information on trees and landscaping near walkways.)

On-Site Circulation and Parking

One of the biggest concerns for pedestrians in site design is conflict with motor vehicles. The following design strategies can minimize conflicts and help clarify pedestrian circulation.

- Clearly define pedestrian access ways. Striping, delineation of walking zones with curbs and landscaping, centralized walkway medians and islands, and textured paving are all good examples of ways to provide defined walking spaces within parking areas and adjacent to vehicular circulation.
- Provide direct access to the building entrance from the street and sidewalk where pedestrians, bicyclists, and transit riders are traveling.
- Locate transit stops adjacent to or on the site, and provide direct access to a variety of origins and destinations on the site. Figure 108 illustrates two site designs that provide good transit access.

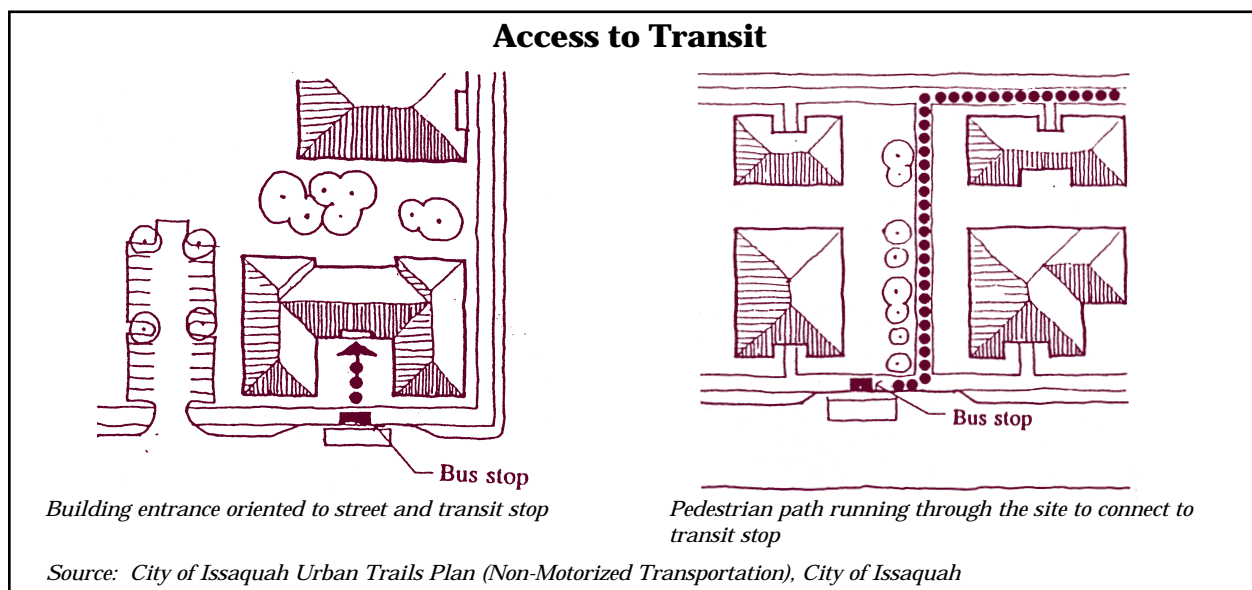

Figure 108

- Provide well delineated and marked drop-off and pickup zones for pedestrians that are separated from the flow of vehicle traffic. These areas, as well as all areas in front of building entrances, should be designated as no parking zones.
- Avoid conflict between pedestrians and motor vehicles by minimizing pedestrian crossings in vehicle circulation zones and designing motor vehicle circulation aisles so that crossing pedestrian travel ways is minimized.
- Consider the use of raised crossings, speed humps, and speed tables to discourage high traffic speeds in parking lots where pedestrian volumes are high.
- Design parking lots so they can be shared by more than one building on the site or by buildings on neighboring sites; also limit parking in certain areas to help increase pedestrian trips and transit use, and

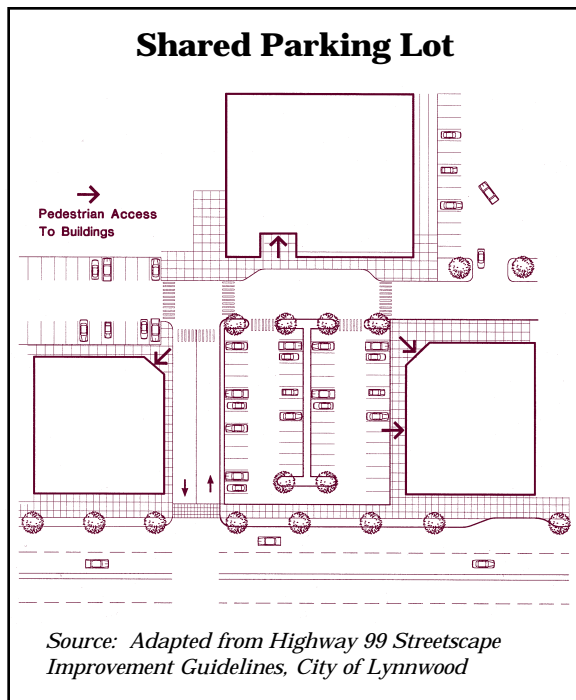

Figure 109

decrease motor vehicle use. Figure 109 illustrates an example of a site design where three buildings share a single parking area.

- Locate parking areas behind buildings or underneath buildings, rather than between the building and the street, where possible.
- Provide one-way traffic flow through parking lots, where appropriate, to minimize pedestrian confusion and conflicts with automobiles.
- Fully illuminate pedestrian walking areas through parking lots.
- Provide good drainage to avoid puddles and concentrated runoff areas across pedestrian walking routes.
- Provide separate access to parking garages and structures for pedestrians.
- Avoid locating pedestrian walking areas near truck and freight delivery zones. Trucks backing up without being able to see pedestrians is a common cause of collisions.



Pavement texture or scoring can be used to delineate the pedestrian travel area in a parking lot.

Building Location and Design

There are several design guidelines related to building location and architecture that encourage pedestrian access by providing an attractive and welcoming environment.

- Locate buildings directly adjacent to the sidewalk and street environment, avoiding placement of parking between the street and buildings. This allows pedestrians to access the buildings directly from the street, encouraging a friendly street atmosphere, and avoids forcing pedestrians to cross parking lots to get to building entrances.
- Create a pedestrian friendly atmosphere by laying out buildings and other site elements in configurations that define spaces for people to walk and gather around the site.
- Create plazas, seating areas, displays and exhibits that draw pedestrians to the building.
- Building design should reflect the character of the surrounding neighborhood or district and respond to the preferences of the community.
- Building wall design and finishes that relate to pedestrian scale should be provided on sides of the building that face towards streets and pedestrian access ways. Architectural elements such as windows, balconies, and entries that “create a complementary pattern or rhythm, dividing large buildings into smaller identifiable pieces” should be encouraged. (*Definitions Related to the Draft Villages and Centers Ordinance*, City of Olympia Planning Department)
- Color, texture, landscaping (climbing vines) and other techniques can soften hard surfaces and bring human scale to building frontages. Blank walls are not desirable.
- On sites where there are a high volume of pedestrians entering the building and traveling across vehicle circulation (at shopping centers and grocery stores), the area in front of the building(s) can be striped or delineated with special paving to direct pedestrians to the building entrances.
- Pedestrian friendly buildings and businesses should include displays, signs, retail features and outdoor seating areas combined with wide storefront walkways to welcome the pedestrian .



Pedestrian access to building entrances should be well delineated.



Pedestrian scale architecture along pedestrian access ways invites pedestrians into businesses.

Landscaping and Furnishings

Successful pedestrian environments provide furnishings and create attractive settings for pedestrians to gather, rest, socialize, and orient themselves. Examples of complementary elements on pedestrian oriented sites include:

- Trees of heights and patterns complementary to human scale, with high branches and upward branching habits along walking areas, and with the capability to provide shade and shelter; trees should be installed to avoid buckling of adjacent pavement by root systems
- Perimeter landscaping with defined edges that reduce the impact of parked vehicles and enhance the streetscape
- Shrubs and ground covers that don't block walkways or interfere with visibility and security
- Shopping cart storage in several convenient and easy to find locations
- Wind screens to protect pedestrians from cold winds, particularly in downtown areas where wind tunnels are often created
- Benches or seating areas outdoors or in building alcoves that allow pedestrians to stop and rest
- Access to restrooms
- Strategically located garbage receptacles and cigarette ash cans that help keep an area clean and attractive; and fully screened garbage bins with self closing doors and landscaping

- Public artwork that creates interest in a place as a destination

Ramps, Stairways, and Steps

Pedestrian routes with stairways and steps should be avoided where possible, and ramps should be provided to allow easy access for everyone. More information about ramp design is provided in Toolkit Section 2 — Accessibility.

Sometimes steps and stairways are unavoidable in areas where there are significant grade changes. When stairways and steps must be installed in pedestrian environments, several design guidelines should be followed. Some of the most important guidelines are described in the following text. Please check other sources for more detailed information.

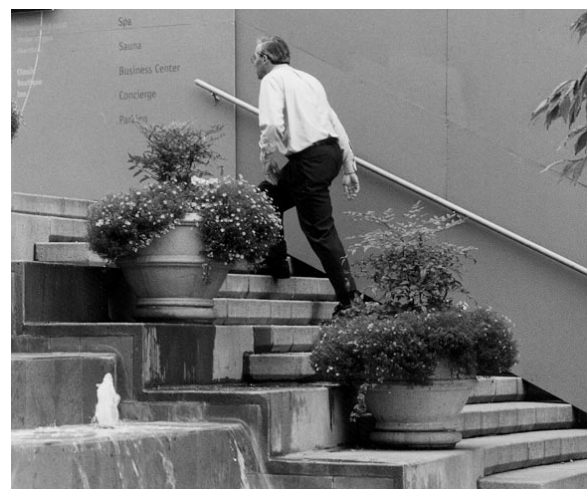

Stairs are often necessary in areas of significant grade changes.

Stairway Width

The minimum width of public stairways should be 1.5 meters (5 feet), and the minimum width for private stairways should be 1.1 meters (4.5 feet).

Step Dimensions

Treads and risers should be uniform in height and depth, with treads no less than 0.3 meters (11 inches) wide and risers no deeper than 0.2 meters (7.5 inches). It is generally preferred that risers for outdoor stairways be a minimum of 11.2 centimeters (4.5 inches) and a maximum of 17.5 centimeters (7 inches) in depth.

Tread to Riser Ratio

The tread to riser ratio should be consistent. A typical formula for tread to riser ratio is:

$$2R + T = 65.0 \text{ to } 67.5 \text{ cm (26 to 27 inches)}$$

where R = riser and T = tread

Height between Landings

Typical height between landings can vary. The *Uniform Building Code* allows up to a maximum height of 3.8 meters (12 feet). Lesser heights are generally recommended to provide more frequent resting opportunities for pedestrians and to breakup the visual expanse of the stairway.

Landing Dimensions

Landings should be long enough to allow a minimum of three strides on the landing before proceeding onto the next set of steps. A 1.5-meter (5-foot) landing is a typical minimum length. Longer landings are typically in lengths of multiples of 1.5 meters (5 feet). The width of the landing should be at

least the width of the stairway. Landing placement for stairways is illustrated in Figure 110.

Tread Design

Nosings, the outer exposed corners of steps or stairs, should not be abrupt. Designs that create a potential tripping hazard should be avoided. Nosings should be easy to see and not obscured by confusing surface patterns. Nosing edges should be chamfered or have rounded corners. Beveled shadow lines help to create a visual distinction between steps. The heights of the bevels should be kept to a minimum to avoid tripping, with nosing undersides not exceeding 1.3 centimeters (0.5 inches). Closed, beveled risers are preferred over 90-degree square risers, risers with recesses, or open steps. Figure 111 illustrates recommended nosing configurations. Treads should be pitched downgrade at a 2 percent slope for proper drainage.

Sites Used Exclusively by Pedestrians

Pedestrian malls, plazas, and special districts including tourist and recreation sites, are often developed for either exclusive use by pedestrians or with the focus that pedestrians are the primary user group. These spaces provide important opportunities to increase pedestrian travel in our communities and the enjoyment of Washington's unique features. Since these sites serve high numbers of pedestrians, they are usually designed with the specific needs of pedestrians in mind. Figure 112 (on page 197) illustrates an example of a pedestrian plaza design.

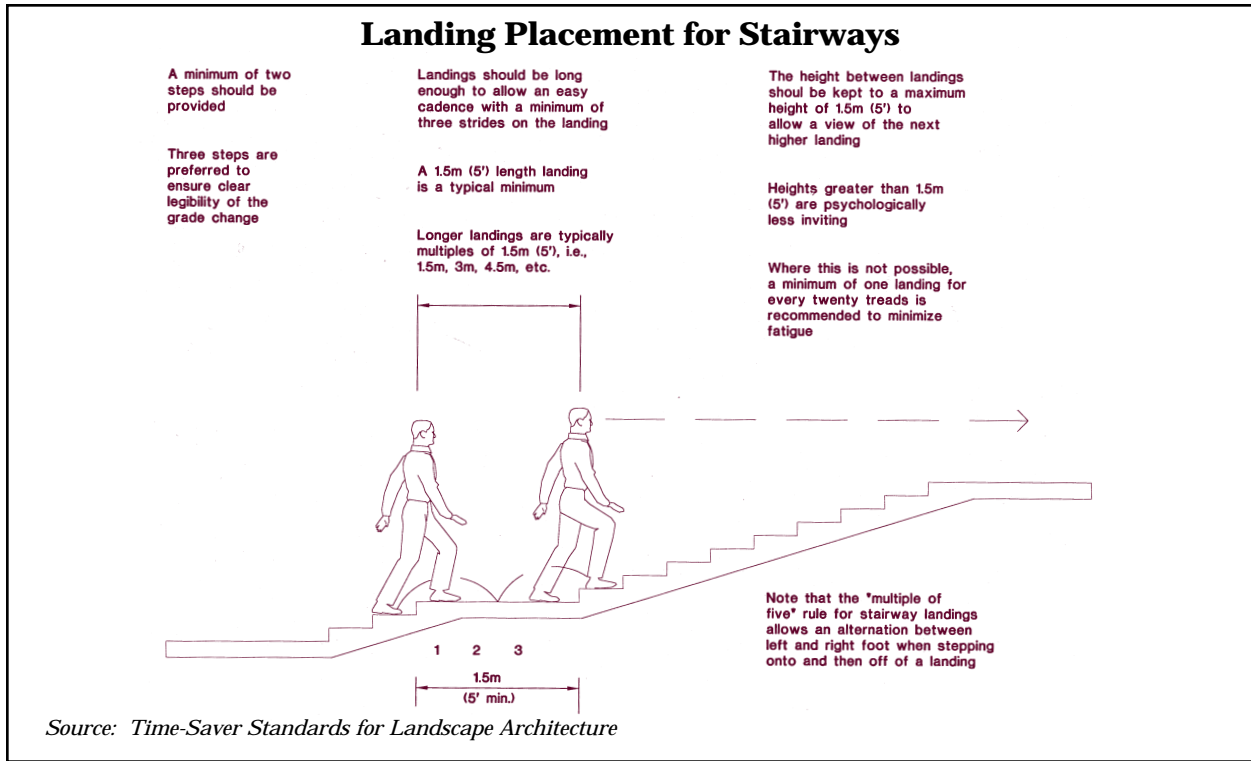

Figure 110

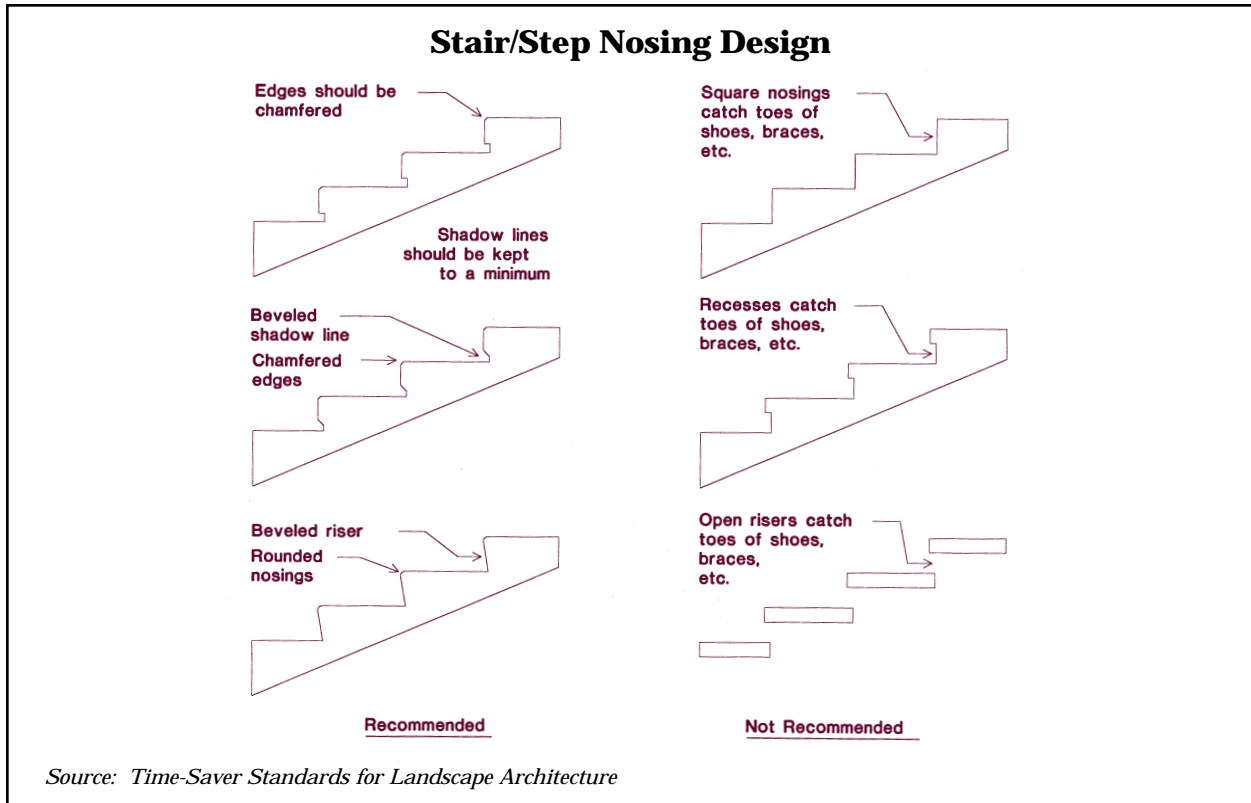

Figure 111

Pedestrian Plaza



Source: Vision 2020 Growth and Transportation Strategy for the Central Puget Sound Region, Puget Sound Regional Council

Figure 112

Sometimes turning over a street for use entirely by pedestrians is a failure for downtown businesses, because they rely on visibility from passing vehicles. Conversely, the use of underground walkways, skywalks, and other systems that take pedestrian activity away from the street can also sometimes reduce the vitality of downtown street level retail. In some cases, exclusive pedestrian facilities are successful; mostly where there are a diverse mix of uses concentrated around the mall or plaza with office workers or college students nearby.

Many urban planning experts agree that the vitality of downtown areas is strengthened when streets serve a mix of transportation modes (pedestrians, bicyclists, transit, and motor vehicles) with the needs of all user groups being carefully considered and balanced in the planning and design process.

Design guidelines that can help to establish pedestrian malls, plazas and special districts as vibrant public gathering spaces are listed below.

- Special paving and accents can enhance plazas and special districts and provide a clear message to tourists as to where they should walk.
- With many tourist attractions and recreation areas located adjacent to busy highways, pedestrian access is sometimes a major concern, especially with the high visitation some of these sites receive. Consider grade separated crossings in these areas, but only if their use will be convenient for pedestrians.
- Drop-off and pickup zones for buses, trolleys, and other touring vehicles should be clearly delineated and located to avoid interrupting pedestrian travel along sidewalks and impeding views of pedestrians and motorists.
- Signing is an important tool in these areas, and can be used both to identify elements within the district and to clearly orient pedestrians.
- Maps engraved in sidewalks or on manhole covers provide a unique opportunity to direct pedestrians.
- Eliminate left-turns and free-right turns at intersections where high volumes of pedestrians cross.
- Create places where pedestrian activity thrives by introducing, special entertainment, music, concessions, seating, and outdoor cafes.

Strategy for Increasing Pedestrian Travel — Mixed Use Site Development

Over the past 50 years, arrangement and design of land uses has been scaled to driving rather than walking. Momentum in many communities is mixed use site development, where compatible land uses are developed on a single site. Mixed use development was an integral component of traditional towns built before the automobile became the focus. Figure 113 illustrates a mixed use site development concept.

Examples of mixed use include apartments located over retail shops or housing, services, and shopping opportunities all sited within a convenient walking distance, usually 0.4 kilometers (0.25 miles) or less). *A Guide to Land Use and Public Transportation, Volume II* by SNO-TRAN identifies three basic criteria of successful mixed use developments:

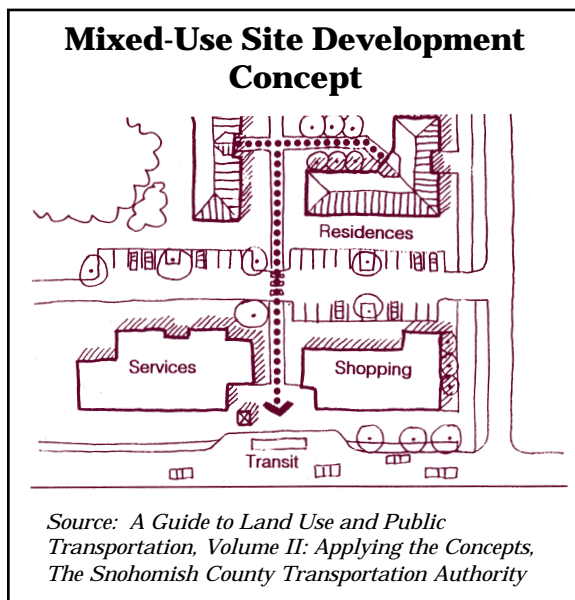

Figure 113

- Complementary land uses
- Located within convenient walking distance of each other
- Connected by safe, direct walkways

Table 59 provides a checklist for successful mixed use site developments.

Checklist for Successful Mixed Use Site Developments

- Are the uses complementary?
- Are the uses located within convenient walking distance of each other?
- Are the uses linked by sidewalks or paved paths?
- Are the walking routes short and direct?
- Do the buildings fit with and complement each other?
- Do the uses create activity at different times of the day?
- Is parking kept out of the pedestrian's path of travel?
- Do the uses support one another economically?

Source: *A Guide to Land Use and Public Transportation, Volume II: Applying the Concepts*,
The Snohomish County Transportation Authority

Table 59

Other Sources of Information

The following sources of information are recommended for site design for pedestrians. Please see the Resource Guide included at the end of this guidebook for complete bibliography information.

A Guide to Land Use and Public Transportation, Volume II: Applying the Concepts, The Snohomish County Transportation Authority

Accessibility Design for All, An Illustrated Handbook, 1995 Washington State Regulations, Barbara L. Allan and Frank C. Moffett, AIA, PE

Accommodating the Pedestrian, Adapting Towns and Neighborhoods for Walking and Bicycling, Richard K. Untermann

Bus Stop Placement and Design, Tri-Met

City Comforts, How to Build An Urban Village, David Sucher

City of Issaquah Urban Trails Plan (Non-Motorized Transportation), City of Issaquah

City, Rediscovering the Center, William H. Whyte

Design and Safety of Pedestrian Facilities, A Proposed Recommended Practice of the Institute of Transportation Engineers, ITE Technical Council Committee 5A-5

Designing Urban Corridors, Kirk R. Bishop

Developing Your Center: A Step-by-Step Approach, Puget Sound Regional Council

Effects of Site Design on Pedestrian Travel in Mixed-Use Medium Density Environments, Anne Vernez-Moudon, PhD

Handbook of Landscape Architectural Construction, Volume Two, Site Works, Maurice Nelischer

Handbook for Walkable Communities, Washington State Pedestrian Facilities Planning and Design Courses, Dan Burden and Michael Wallwork, PE

Mukilteo Multimodal Terminal & Access Study, Urban Design Concepts, Hewitt Isley

Pedestrian Corridor and Major Public Open Space Design Guidelines, Don Miles Associates/PPS

Pedestrian Malls, Streetscapes, and Urban Spaces, Harvey M. Rubenstein

Site Planning, Kevin Lynch

Site Planning and Community Design for Great Neighborhoods, Frederick D. Jarvis

Time-Saver Standards for Landscape Architecture, Design and Construction Data, Charles W. Harris, Nicholas T. Dines

Urban Spaces, David Kenneth Specter

Vision 2020, Growth and Transportation Strategy for the Central Puget Sound Region, Puget Sound Regional Council

Safety in Work Zones

This Toolkit Section Addresses:

- *Protective Barriers*
- *Covered Walkways*
- *Sidewalk Closure During Construction*
- *Intersections and Crossings Near Work Zones*
- *Maintenance*
- *Other Sources of Information*

Pedestrian safety is an important issue in and around work zones. Pedestrians travel at slower speeds than other modes of transportation and are more susceptible to the impacts of access, dirt, noise, and fumes from construction areas. Temporary access and detours should be provided to ensure safe unimpeded pedestrian travel in and around work zones. Access to pedestrian facilities, such as bus stops, crosswalks, and links between origins and destinations should be provided. Pedestrians should feel safe and secure when traveling near work zones.

Urban and suburban settings have the highest volume of pedestrian traffic, and construction projects are most likely to impact pedestrians in these areas. Safe and convenient passage through or around a work zone should be provided. Pedestrians may ignore a detour that is out of the direction of their travel.

Local jurisdictions responsible for traffic safety in work areas should train construction inspection staff to recognize improper and unsafe pedestrian facilities during construction.



Fencing used to secure a work area supported by blocks needs to be positioned to avoid creating obstacles or tripping hazards for pedestrians.

Considerations for Pedestrian Safety in Work Zones

- Separate pedestrians from conflicts with construction vehicles, equipment, and operations
- Separate pedestrians from conflicts with traffic traveling around or through the construction area
- Provide a safe, convenient, and accessible route that maintains the direction and character of the original route
- Minimize work vehicle traffic crossing pedestrian routes by minimizing the number of construction access points
- Communicate construction activity and pedestrian impacts through local media and pedestrian interest groups
- Avoid using delineating materials that are difficult to recognize by people with impaired sight

Source: Based on ITE Design and Safety of Pedestrian Facilities; adapted and expanded for this Guidebook

Table 60

Protective Barriers

Near work zones where higher volumes of pedestrian traffic or school children exist, pedestrian fences or other protective barriers may be needed to prevent pedestrian access into a construction area. Pedestrian fences need to be high enough to discourage pedestrians from climbing over the fence. Table 60 lists considerations for encouraging safety in work zones.

Covered Walkways

For construction of structures adjacent to sidewalks, a covered walkway may be

required to protect pedestrians from falling debris. Covered walkways should be designed to provide:

- sturdiness
- adequate light for nighttime use and safety
- proper sight distance at intersections and crosswalks
- adequate and impact resistant longitudinal separation from vehicles on higher speed streets; for work zones adjacent to high speed traffic, wooden railings, chain link fencing, and other similar systems are not acceptable

Sidewalk Closure During Construction

It is undesirable to close sidewalks or pathways during construction. If unavoidable, consider:

- using barricades and cones to create a temporary route
- clearly defining any detoured routes
- maintaining a minimum width and smooth surface for wheelchair access
- protecting pedestrians from vehicle traffic
- protecting pedestrians from hazards, such as holes, debris, dust, and mud

If a temporary route is created in the roadway adjacent to the closed sidewalk, the parking lane or one travel lane may be used for pedestrian travel, with appropriate barricades, cones, and signing, as illustrated in Figure 114 . When a parking lane or travel

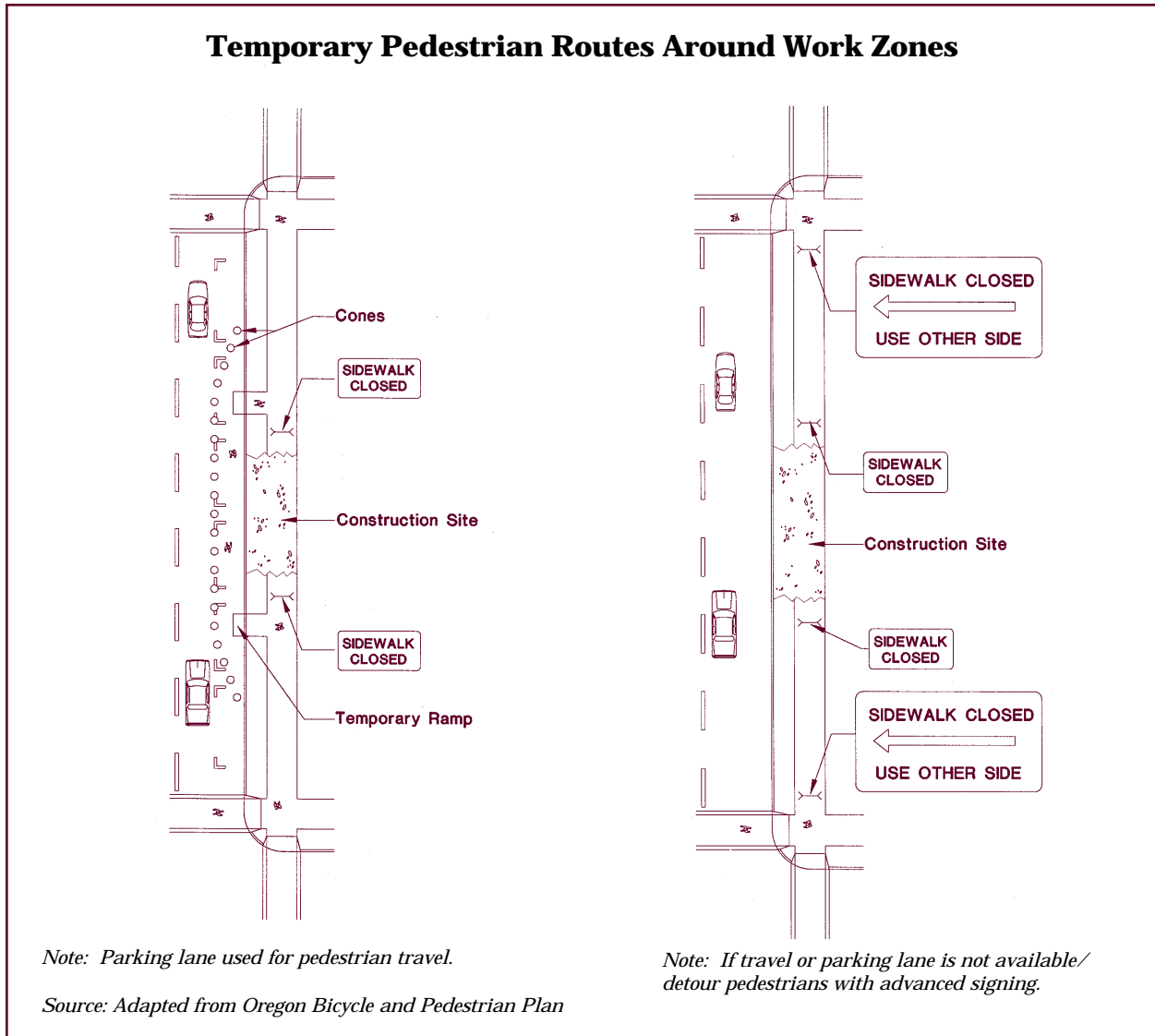

Figure 114

lane is not available for closure, pedestrians must be detoured with advance signing in accordance with the *Manual on Uniform Traffic Control Devices*. Signs should be placed to avoid blocking the path of pedestrians.

Intersections and Crossings Near Work Zones

- At intersections, avoid closing crosswalks.
- At signalized intersections, mark temporary crosswalks if they are relocated from their previous location. Maintain access to pedestrian push buttons.
- Include pedestrian phases in temporary signals.
- Place advanced signing at intersections to alert pedestrians of mid-block work sites and direct them to alternate routes.

Maintenance

Pedestrian facilities in and adjacent to work zones should be maintained to provide safety and functionality. Proper maintenance will maximize the effectiveness and life of work zone pedestrian facilities. Poor maintenance can result in increased work zone accidents. Table 61 summarizes recommended maintenance activity for pedestrian facilities in and adjacent to work zones.

Other Sources of Information

Bicycle and Pedestrian Facilities Planning and Design Guidelines, North Central Texas Council of Governments

Florida Pedestrian Planning and Design Guidelines

Oregon Bicycle and Pedestrian Plan

ITE Design and Safety of Pedestrian Facilities

Work Zone Maintenance	
<i>Issue</i>	<i>Recommended Maintenance</i>
Temporary pathways constructed of inexpensive, short-life materials	Pathway surfaces should be inspected regularly; surface materials should be treated with nonslip materials; surface materials with holes, cracks, or vertical separation should be replaced
Detour pedestrian paths increase volumes on detour roadway	Detour pathway should be inspected regularly for adequacy of signal timing, signing, and pedestrian traffic hazards
Construction material debris on pathway	Require contractor to maintain clear pathways
Changing pedestrian route during construction	Inspect pedestrian signing regularly to ensure a clearly understood pathway
Damaged traffic barriers	Replace and reevaluate adequacy for pedestrian safety

Source: Adapted from Bicycle and Pedestrian Facilities Planning and Design Guidelines, North Central Texas Council of Governments

Table 61

Resource Guide

A Citizen's Guide to the Draft Comprehensive Plan, 1994 - 2014, Toward a Sustainable Seattle, Seattle Planning Department, Seattle, Washington.

A Guide to Land Use and Public Transportation, The Snohomish County Transportation Authority, Lynnwood, Washington, December 1993.

A Guide to Land Use and Public Transportation, Volume II: Applying the Concepts, The Snohomish County Transportation Authority, Lynnwood, Washington, December 1993.

A Guidebook for Residential Traffic Management, Final Report, Washington State Department of Transportation, TransAid Service, Olympia, Washington, December 1994.

A Guidebook for Student Pedestrian Safety, Final Report, KJS Associates Inc., MacLeod Reckord, and Educational Management Consultants, Washington State Department of Transportation, Washington State Traffic Safety Commission, Superintendent of Public Instruction, Olympia, Washington, August 1996.

A Policy on Geometric Design of Highways and Streets, 1994, American Association of State Highway and Transportation Officials (AASHTO), Washington, DC, 1995.

A Sampler of Neighborhood Traffic Calming Efforts, Chris Leman, Seattle, Washington.

"A Toolbox Approach to Residential Traffic Management," Joseph Savage and R. David MacDonald, *ITE Journal*, Volume 66, Number 6, pages 24-30, Institute of Transportation Engineers, Washington, DC, June 1996.

A Working Approach to Accessibility in Public Rights of Way, Montana Department of Transportation, Scottsdale, Arizona, August 1996.

AAA Traffic Safety Services Catalog, American Automobile Association, Traffic Safety Department, Seattle, Washington, April 1990.

Accessible Sidewalks: A Design Manual, US Architectural and Transportation Barriers Compliance Board (The Access Board), January 1997.

Accessibility Design for All, An Illustrated Handbook, 1995 Washington State Regulations, Barbara L. Allan and Frank C. Moffett, AIA, PE, AIA Washington Council, Olympia, Washington, September 1995.

Accessibility Handbook for Transit Facilities, Ketron Division of the Bionetics Corporation, US Department of Transportation, Federal Transit Administration, Washington, DC, January 1993.

Accommodating the Pedestrian, Adapting Towns and Neighborhoods for Walking and Bicycling, Richard K. Untermann, Van Nostrand Reinhold Company, Inc., New York, New York, 1984.

Resource Guide

Americans With Disabilities Act (ADA) Accessibility Guidelines for Buildings and Facilities; State and Local Government Facilities; Interim Final Rule, Federal Register, Part II, Architectural and Transportation Barriers Compliance Board, 36 CFR Part 1191, June 1994.

Americans With Disabilities Act Accessibility Guidelines for Buildings and Facilities Transportation Facilities Transportation Vehicles, United States Access Board, Washington, DC, September 1994.

Americans With Disability Act Accessibility Requirements, US Architectural and Transportation Barriers Compliance Board, Washington, DC, December 1991.

Americans With Disabilities Act Solutions, Eric Dibner, City of Berkeley, Berkeley, California.

An Analysis of Pedestrian Conflicts with Left-Turning Traffic, Dominique Lord, Transport Safety Group, University of Toronto, Transportation Research Board 75th Annual Meeting, Washington, DC, January 1996.

An Illustrated Handbook for Barrier Free Design, Washington State Rules and Regulations, Barbara Allan and Frank C. Moffett, AIA, PE, Washington State Building Code Advisory Council, Washington, March 1985.

Bellevue Transit Neighborhood Links Project, Otak, Inc., City of Bellevue Transportation Department, Bellevue, Washington, September 1996.

Bicycle and Pedestrian Facilities Planning and Design Guidelines, Department of Environmental Resources, Department of Transportation, North Central Texas Council of Governments, Arlington, Texas, December 1995.

Bicycle and Pedestrian Transportation in Japan and Australia: Lessons for America, M.A. Replogle, September 1993.

Bicycle and Pedestrian Level of Service Performance Measures and Standards for Congestion Management Systems, Linda B. Dixon, Delaware Department of Transportation, Dover, Delaware, August 1995.

Bicycle and Pedestrian Transportation, Redmond Comprehensive Plan, City of Redmond, Redmond, Washington, 1994.

"Boulder Brings Back the Neighborhood Street," John Fernandez, *Planning*, American Planning Association, June 1994.

Bus Stop Placement and Design, Tri-Met, June 1995.

Childhood Injury Prevention, A Directory of Resources and Program in Washington State, Washington State Department of Health, Office of Emergency Medical and Trauma Prevention, Olympia, Washington, June 1995.

City Comforts, How to Build An Urban Village, David Sucher, City Comforts Press, Seattle, Washington, 1995.

City of Issaquah Urban Trails Plan (Non-Motorized Transportation), City of Issaquah, Issaquah, Washington, April 1995.

City of Pullman Pedestrian/Bicycle Circulation Plan, City of Pullman, Pullman, Washington, May 1996.

City, Rediscovering the Center, William H. Whyte, Doubleday, New York, New York, 1990.

Creating Bicycle-Friendly and Walkable Communities, Pro Bike Pro Walk 96 Resource Book, Bicycle Federation of America, Pedestrian Federation of America, Portland, Maine, 1996.

Creating Transportation Choices Through Zoning, A Guide for Snohomish County Communities, The Snohomish County Transportation Authority, Lynnwood, Washington, October 1994.

Curb Ramps for Accessible Pathways, Bureau of Transportation Engineering and Development, Office of Transportation, City of Portland, Portland, Oregon, 1993.

Design and Safety of Pedestrian Facilities, A Proposed Recommended Practice of the Institute of Transportation Engineers, ITE Technical Council Committee 5A-5, Chapel Hill, North Carolina, December 1994.

Design Guidelines, Building/Sidewalk Relationships, Central Business District, City of Bellevue, Bellevue, Washington, November 1983.

Design Manual, Washington State Department of Transportation, Engineering Publications, Olympia, Washington, June 1989.

Design of Pedestrian Facilities, ITE Committee 5A-5, Draft Report Chapters, January 1992.

Designing Urban Corridors, Kirk R. Bishop, American Planning Association, Planning Advisory Services, Report Number 418, Washington, DC, September 1989.

Developing Your Center: A Step-by-Step Approach, Puget Sound Regional Council, Seattle, Washington, May 1996.

Development Manual, Transportation Department, Parks & Community Services Department, City of Bellevue, Bellevue, Washington, 1996.

Easy Walking Workplace, Washington State Energy Office and the Energy Outreach Center, Olympia, Washington, 1994..

Effects of Site Design on Pedestrian Travel in Mixed-Use Medium Density Environments, Anne Vernez-Moudon, PhD, University of Washington College of Urban Planning, Seattle, Washington, December 1996.

Elementary School Catalog, AAA Foundation for Traffic Safety, Washington, DC, 1995.

Engineering Design and Development Standards, Snohomish County Public Works, Lynnwood, Washington, June 1992.

Evaluating Pedestrian Environments: Proposals for Urban Form Measures of Network Connectivity, With Case Studies of Wallingford in Seattle and Crossroads in Bellevue, Washington, Paul Mitchell Hess, University of Washington, Seattle, Washington, 1994.

Field Studies of Pedestrian Walking Speed and Start-Up Time, Richard L. Knoblauch, Martin T. Pietrucha, and Marsha Nitzburg, Transportation Research Record 1538, US Department of Transportation Committee on Pedestrians, Washington, DC.

Resource Guide

Flashing Beacons, Association of Washington Cities and the County Road Administration Board.

Florida Pedestrian Planning and Design Guidelines, University of North Carolina, Highway Safety Research Center, Florida Department of Transportation, May 1996.

Great Streets, Allan B. Jacobs, MIT Press, Cambridge, Massachusetts, 1993.

Guide for the Development of Bicycle Facilities, American Association of State Highway and Transportation Officials, August, 1991.

Guide to Barrier-Free Recreation at Selected Sites, Washington State Department of Natural Resources Engineering Division, Resource Mapping Section, Olympia, Washington, 1995.

Guidelines for the Installation of Crosswalk Markings, Steven A. Smith and Richard L. Knoblauch, American Automobile Association, Transportation Research Board, National Research Council, Washington, DC, 1988.

Handbook of Landscape Architectural Construction, Volume Two, Site Works, Maurice Nelischer, Landscape Architecture Foundation, Washington, DC, 1988.

Handbook for Walkable Communities, Washington State Pedestrian Facilities Planning and Design Courses, Dan Burden and Michael Wallwork, PE.

Identifying High-Hazard Locations for Pedestrian and Bicycle Crashes, Richard A. Raub, Northwestern University Traffic Institute, Transportation Research Board 75th Annual Meeting, Washington, DC, January 1996.

Implementing Effective Travel Demand Management Measures: Bicycle/Pedestrian Facilities and Site Improvements Section, United States Department of Transportation, Washington, DC, June 1993.

Kids and Cars Don't Mix, Seattle Engineering Department, Seattle, Washington.

King County Neighborhood Traffic Control Demonstration Program, The KJSA Team, King County Department of Public Works Division of Roads and Engineering, Seattle, Washington, March 1989.

King County Nonmotorized Transportation Plan, King County Department of Public Works Roads Division Transportation Planning Section, King County, Washington, May 1993.

King County Regional Trails Plan, Parks, King County, Parks, Planning and Resources Department, Parks Division, King County, Washington, October 1992.

Land Use Strategies for More Livable Places, Steve Weissman and Judy Corbett, The Local Government Commission, Sacramento, California, May 1992.

Linking Bicycle/Pedestrian Facilities With Transit, M. Replogle and H. Parcels, October 1992.

Livable Neighborhoods: Rethinking Residential Streets, American Public Works Association and the University of Wisconsin-Madison, A Satellite Course Held June 19, 1996.

Livable Streets, Donald Appleyard, University of California Press, Los Angeles, Californian, 1981.

“Make Their First Steps Safe Ones,” Robert B. Overend, *Traffic Safety*, November/December 1988.

Manual on Uniform Traffic Control Devices for Streets and Highways, 1988 Edition, US Department of Transportation, Federal Highway Administration, US Government Printing Office, Washington, DC, 1988.

Metro Transportation Facility Design Guidelines, Municipality of Metropolitan Seattle, Seattle, Washington, March 1991.

Metrorail Orange Line Bicycle Pedestrian Access Study, Northern Virginia, Christopher Neumann, April 1989.

Mukilteo Multimodal Terminal & Access Study, Urban Design Concepts, Hewitt Isley, City of Mukilteo, Mukilteo, Washington, March 1995.

Municipal Strategies to Increase Pedestrian Travel: Final Report, Washington State Energy Office, Olympia, Washington, August 1994.

National Bicycling and Walking Study, Case Study No. 2, The Training Needs of Transportation Professionals Regarding the Pedestrian and Bicyclist, US Department of Transportation, Federal Highway Administration, Washington, DC, 1992.

National Bicycling and Walking Study, Case Study No. 4, Measures to Overcome Impediments to Bicycling and Walking, US Department of Transportation, Federal Highway Administration, Washington, DC, August 1993.

National Bicycling and Walking Study, Case Study No. 5, An Analysis of Current Funding Mechanisms for Bicycle and Pedestrian

Programs at the Federal, State, and Local Levels, US Department of Transportation, Federal Highway Administration, Washington, DC, April 1993.

National Bicycling and Walking Study, Case Study No. 18 Final Report, Analyses of Successful Provincial, State, and Local Bicycle and Pedestrian Programs in Canada and the United States, US Department of Transportation, Federal Highway Administration, Washington, DC, March 1993.

National Bicycling and Walking Study: Transportation Choices for a Changing America, Report to Congress, C. Zegeer and D. Feske, March 1994.

Nature Trail Guide to the Quiet Trails of the City of Bellevue, Habitrek, Inc., City of Bellevue Parks & Recreation Department, Bellevue, Washington.

NE 124th Street Sidewalk, 100th Avenue NE and 108th Avenue NE Median Islands, Specifications and Contract Documents, KPG, Inc., City of Kirkland, Kirkland, Washington, January 1996.

Nondiscrimination on the Basis of Disability in State and Local Government Services; Final Rule, Federal Register, Part IV, Department of Justice, Office of the Attorney General, 28 CFR Part 35, July 1991.

Non-Motorized Access to Transit, Final Report, Wilbur Smith Associates, Regional Transportation Authority, July 1996.

Non-Motorized Access to Transit, Technical Appendices, Wilbur Smith Associates, Regional Transportation Authority, July 1996.

Nonmotorized Transportation Around the World, Safety and Human Performance,

Resource Guide

Transportation Research Record Number 1441, Planning, Administration, and Environment, Transportation Research Board National Research Council, National Academy Press, Washington, DC, October 1994.

Nonmotorized Transportation Research, Issues, and Use, Transportation Research Record Number 1487, Planning and Administration, Safety and Human Performance, Transportation Research Board National Research Council, National Academy Press, Washington, DC, July 1995.

Observational Survey of Driver Compliance with the Pedestrian Crosswalk Law, Charlie Saibel, Philip Salzberg, PhD, Richard Thurston, Washington Traffic Safety Commission, Olympia, Washington, March 1995.

Oregon Bicycle and Pedestrian Plan, An Element of the Oregon Transportation Plan, Oregon Department of Transportation Bicycle and Pedestrian Program, June 1995.

Paths for People, Snohomish County, Lynnwood, Washington, 1994.

“Pedestrian Actuated Crosswalk Flashing Beacons,” John W. VanWinkle, City of Chattanooga Traffic Engineering Division, *ITE Journal*, January 1997.

Pedestrian and Bicycle Transportation Plan, City of Bellevue Transportation Department Planning and Programming Division, Bellevue, Washington, May 1993.

Pedestrian Corridor and Major Public Open Space Design Guidelines, Don Miles Associates/PPS, City of Bellevue, Bellevue, Washington, December 1981.

Pedestrian Crossing Study, Final Submittal, Pedestrian Traffic Control Measures, Arctic Slope Consulting Group, Inc., City of Bellevue Public Works/Utilities Department, Transportation Division, Bellevue, Washington, March 1991.

Pedestrian Facilities for Transit Access Project, Evaluation of Needs and Constraints, Cambridge Systematics, Inc., June 1996.

Pedestrian Facilities in South Africa: Research and Practice, Hubrecht Ribbens, Transportation Research Record 1538.

Pedestrian Improvements Demonstration Project, Kirkland Avenue at Main Street, Kirkland Avenue at Third Street, Lake Street South, Specifications and Contract Documents, KPG, Inc., City of Kirkland, Kirkland, Washington, June 1996.

Pedestrian Malls, Streetscapes, and Urban Spaces, Harvey M. Rubenstein, John Wiley & Sons, Inc., New York, 1992.

Pedestrian Master Plan, Preliminary Discussion Draft, City of Portland, Office of Transportation, Engineering and Development, Pedestrian Program, Portland, Oregon, October 1995.

Pedestrian Passport, Think Globally, Walk Locally, City of Portland, Portland, Oregon, April 1994.

Pedestrian Program, City of Portland Bureau of Transportation Engineering and Development, Portland, Oregon, April 1994.

Pedestrian Signal Installation Policy, David I. Hamlin and Associates, City of Bellevue, Bellevue, Washington, March 1987.

“Pedestrian Signs at Crosswalks Spark Controversy in New Jersey,” *The Urban Transportation Monitor*, Volume 10, Number 19, Lawley Publications, Burke, Virginia, October 11, 1996.

Pierce County Road Standards, Pierce County Department of Public Works and Utilities, Transportation Services, July 1992.

Planning and Design for Transit, Tri-County Metropolitan Transportation District of Oregon, Portland, Oregon, March 1993.

Planning and Implementing Pedestrian Facilities in Suburban and Developing Rural Areas Research Report, S.A. Smith, K.S. Opiela, and L.L. Impett, JHK & Associates, National Cooperative Highway Research Program Report 294A, Transportation Research Board, National Research Council, Washington, DC, June 1987.

Planning and Implementing Pedestrian Facilities in Suburban and Developing Rural Areas State-of-the-Art Report, S.A. Smith, K.S. Opiela, and L.L. Impett, JHK & Associates, National Cooperative Highway Research Program Report 294B, Transportation Research Board, National Research Council, Washington, DC, June 1987.

Planning Design and Maintenance of Pedestrian Facilities, Goodell-Grivas, Inc., US Department of Commerce National Technical Information Service, McClean, Virginia, March 1989.

Portland Pedestrian Crossing Toolbox for Pedestrian Program Bureau of Transportation Engineering and Development, Charles V. Zegeer, PE, City of Portland, Portland, Oregon, June 1995.

Preliminary Statewide Multimodal Transportation Plan 1994, Washington State Department of Transportation, Olympia, Washington, December 1994.

Preparing Your Own Design Guidelines, A Handbook for Seattle' Neighborhoods, City of Seattle Department of Construction and Land Use and Planning Department, Seattle, Washington, October 1993.

Proposed Warrants for South African Mid-Block Pedestrian Crossings, H. Ribbens, G. Brafman Bahar, National Road Safety Council, Technical Report RF/2/81, Pretoria, South Africa, May 1981.

Public Streets for Public Use, Anne Vernez Moudon, Van Nostrand Reinhold Company, Inc., New York, New York, 1987.

PUFFIN and PELICAN Crossings to Reduce Delays, Office of the Minister for Roads and Ports, 1st Kennett Ministry, News Release, June 3, 1994.

Radpeds Pedestrian Action, Q. Why did the Pedestrians Cross the Road, Willamette Pedestrian Coalition, Portland, Oregon.

Reclaiming Our Streets, Traffic Solutions, Safer Streets, More Livable Neighborhoods, Community Action Plan To Calm Neighborhood Traffic, Reclaiming Our Streets Task Force, City of Portland Bureau of Traffic Management, Portland, Oregon, February 1993.

Recommendations for Accessibility Guidelines: Recreational Facilities and Outdoor Developed Areas, Recreation Access Advisory Committee, US Architectural and Transportation Barriers Compliance Board, Washington, DC, July 1994.

Resource Guide

Recommendations for Pedestrian, Bicycle and Transit Friendly Development Ordinances, Draft, Transportation Rule Working Group, Oregon Chapter American Planning Association, Department of Land Conservation and Development, Oregon Department of Transportation, February 1993.

Redevelopment for Livable Communities, Washington State Energy Office, the Washington State Department of Transportation, the Department of Ecology, and the Energy Outreach Center, Olympia, Washington, 1996.

Redmond Comprehensive Plan, City of Redmond, Redmond, Washington, 1995.

Residential Development Handbook for Snohomish County Communities, Techniques to Increase Livability, Affordability and Community Viability, Makers Architecture and Urban Design, Snohomish County Tomorrow, Lynnwood, Washington, March 1992.

Residential Mixed Use Zone, Pedestrian Street Overlay District, City of Olympia Municipal Code, Ordinance 5427, Olympia, Washington, December 1993.

Residential Streets, American Society of Civil Engineers, National Association of Home Builders, and the Urban Land Institute, June 1993.

River District, A Development Plan for Portland's North Downtown, City of Portland, Portland, Oregon.

Safe Walkways for Clark County, 1993-98 Walkway Construction Program, A Report to the Clark County Board of Commissioners. Sharing Our Sidewalks, Ensuring Access in Portland's Shopping and Commercial Districts, Metropolitan Human Rights Commission, Portland, Oregon.

Site Planning, Kevin Lynch, The MIT Press, Cambridge, Massachusetts, April 1974.

Sidewalk and Curb Ramp Design, Governor's Committee on Concerns of the Handicapped, Santa Fe, NM.

Site Planning and Community Design for Great Neighborhoods, Frederick D. Jarvis, National Association of Home Builders, Home Builder Press, Washington, DC, March 1995.

Standard Plans for Road, Bridge and Municipal Construction, Washington State Department of Transportation, American Public Works Association, Washington State Chapter, Washington State Department of Transportation, Engineering Publications, Olympia, Washington, October 1993.

Steppin' Out Safely, Washington State Energy Office, Olympia, Washington, 1994.

Streets for People, A Primer for Americans, Bernard Rudofsky, Doubleday & Company, Inc., Garden City, New York, 1969.

Streetscape Manual, City of Toronto, Resource and Publications Centre, Toronto, Ontario, January 1995.

Sustainable Communities, A New Design Synthesis for Cities, Suburbs and Towns, Sim Van der Ryn and Peter Calthorpe, Sierra Club Books, San Francisco, California, 1991.

Synthesis of Safety Research Pedestrians, University of North Carolina, Chapel Hill, North Carolina, August 1991.

TDM — A Practical Approach: Case Study, Raj. Shanmugam, Moving With Our Times: 1991 ACT International Conference Proceedings, 1994.

The Bellevue Transit Neighborhood Links Project, Final Draft, Otak, Inc., City of Bellevue Transportation Department, Bellevue, Washington, June 1996.

The Car and the City, 24 Steps to Safe Streets and Healthy Communities, Alan Thein Durning, Northwest Environment Watch, Seattle, Washington, 1996.

The Pedestrian Environment, Parsons Brinckerhoff Quade and Douglas, Inc., 1000 Friends of Oregon, 1993.

The Pedestrian Revolution, Streets Without Cars, Simon Brienens and William J. Dean, Vintage Books, New York, 1974.

Time-Saver Standards for Landscape Architecture, Design and Construction Data, Charles W. Harris, Nicholas T. Dines, McGraw-Hill Book Company, New York.

Traditional Neighborhood Development: Will the Traffic Work? Walter Kulash, International Pedestrian Conference, Bellevue, Washington, 1990.

Traffic Calming, Cynthia L. Hoyle, American Planning Association, Planning Advisory Service Report Number 456, Washington, DC, July 1995.

Traffic Calming, A Guide to Street Sharing, Michael J. Wallwork, PE, 1993.

“Traffic Calming — An Overview,” Walter Kulash, Glatting, Jackson Kercher Anglin Lopez Rinehart, Inc., *Surface Transportation Policy Project Progress*, Volume VI, Number 4, Washington, DC, July 1996.

Traffic Calming — The Solution to Urban Traffic and a New Vision for Neighborhood Livability, Citizens Advocating Responsible Transportation, Ashgrove, Queensland, Australia, 1989, and *Sensible Transportation Options for People*, Tigard, Oregon, 1993.

Traffic Engineering for Neo-Traditional Design: An Information Report, Institute of Transportation Engineers, Technical Council Committee 5P-8, Washington, DC, 1994.

Transportation Planning, Volume XXII, Number 2, American Planning Association, Transportation Planning Division, Orlando, Florida, Summer 1995.

Uniform Federal Accessibility Standards, General Services Administration, Department of Defense, Department of Housing and Urban Development, US Postal Service, FED-STD-795, April 1988.

Universal Access to Outdoor Recreation: A Design Guide, PLAII, Inc., Berkeley, California, 1994.

Unsignalized Pedestrian Crossings, New Zealand's Technical Recommendation, Roger C.M. Dunn, Department of Civil Engineering, University of Auckland, New Zealand.

Urban Spaces, David Kenneth Specter, New York Graphic Society Ltd., Greenwich, Connecticut, 1974.

Resource Guide

Using GIS for Transit Pedestrian Access Analysis, Orange County Transportation Authority Transit Programs Department, Transportation Research Board, Washington, DC, 1996.

Vision 2020, Growth and Transportation Strategy for the Central Puget Sound Region, Puget Sound Regional Council, Seattle, Washington, October 1990.

Vision 2020 1995 Update, Puget Sound Regional Council, Seattle, Washington, 1995.

Walk Tall, A Citizen's Guide to Walkable Communities, Version 1.0, Pedestrian Federation of America, Rodale Press, Washington, DC, 1995.

Walkable Communities: Twelve Steps for an Effective Program, Florida Department of Transportation, Tallahassee, Florida, June 1993.

Walking: Facts and Figures, Tom Whitney, Environmental Council of Sacramento, California, 1991.

Walking Shouldn't Be Hazardous to Your Health, Willamette Pedestrian Coalition, Portland, Oregon.

Walking to Work Works Wonders, Washington State Energy Office, Olympia, Washington, February 1994.

Wary Walker's Pedestrian Safety Rodeo, Harborview Injury Prevention & Research Center, National Highway Traffic Safety Administration, 1995.

Washington Bicyclist's Guide, Washington Traffic Safety Commission, Empire Publishing, Inc., Seattle, Washington, 1995.

Washington State Pedestrian Collision Data, 1990 to 1995, Washington State Department of Transportation Transportation Data Office, Olympia, Washington, March 1997.

Washington's Transportation Plan, State Bicycle Transportation and Pedestrian Walkways Plan, Washington State Department of Transportation, Olympia, Washington, September 1995.

Wisconsin Pedestrian Planning Guidance, Guidelines for Metropolitan Planning Organizations and Communities in Planning and Developing Pedestrian Facilities, Wisconsin Department of Transportation, Wisconsin, September, 1993.

Glossary

402

Highway Safety Grant Program (Section 402 funds); for state and community highway safety projects

AASHTO

American Association of State Highway and Transportation Officials

access management

the principles, laws and techniques used to control access to a highway

ADA

Americans with Disabilities Act; civil rights legislation passed in 1990, effective July 1992; mandated sweeping changes in building codes, transportation, and hiring practices to prevent discrimination against persons with disabilities

ADT

average daily traffic; the measurement of the average number of vehicles passing a certain point each day on a highway, road or street

alley

a road primarily used to access the rear of residences and businesses, not designed for general travel

arterial

a street designated to carry traffic, mostly uninterrupted, through an urban area, or to different neighborhoods within an urban area

asphalt concrete

a concrete composition in which asphalt is used as a binder; a material often used for roadway pavement

asphalt shim

a thin strip of asphalt used to fill uneven road surfaces as a temporary measure

at-grade crossing

the general area where two or more roadways, railways, and/or pathways join or cross, as in an “at-grade railroad crossing”

BIA

Business Improvement Association

bicycle

a vehicle having two tandem wheels, a minimum of 14" (35 cm) in diameter, propelled solely by human power, upon which any person or persons may ride. A three-wheeled adult tricycle is considered a bicycle

bicycle facility

any facility provided for the benefit of bicycle travel, including bikeways and parking facilities as well as all other roadways not specifically designated for bicycle use

bicycle lane

a portion of the roadway which has been designated by traffic-control devices for preferential or exclusive use by bicycles

bicycle path

an access route, usually scenic, for the exclusive use of bicycles and pedestrians

bicycle route

a vehicular route, identified by a sign, that provides continuity to the bicycle transportation network

bike lane

a portion of a roadway which has been designated by striping and pavement markings for the preferential or exclusive use of bicyclists

bikeway

a bikeway is created when a road has the appropriate design treatment for bicyclists, based on motor vehicle traffic volumes and speeds: shared roadway, shoulder bikeway, bike lane or bicycle boulevard; another type of facility is separated from the roadway; multi-use path

bollard

a post or similar obstruction that prevents the passage of vehicles; the spacing of bollards usually allows the passage of bicycles and pedestrians; bollards may incorporate lighting

boulevard

street classification encouraging physical design features that provide a parklike atmosphere and/or enhance appreciation or use of adjacent parkland, on a street otherwise intended to move traffic

buffer

a strip of land that physically and/or visually separates two land uses, especially if the uses are incompatible

bus pullout/turnout

a section of pavement at a bus stop that allows buses to leave the flow of traffic while stopped to load and unload passengers

bus shelter

any covered area within a bus stop zone that provides riders protection from the weather

bus zone

a portion of the roadway along the curb which is reserved for loading and unloading of either local transit or school buses

catch basin

a receptor, typically of masonry with cast iron top grate, that receives surface water runoff or drainage

CBD

Central Business District; a traditional downtown area usually characterized by established business fronting the street, sidewalks, slow traffic speeds, on-street parking and a compact grid street system

center line

the line separating traffic traveling in opposite directions

chip seal

a thin asphalt surface treatment used to waterproof and improve the texture of the wearing surface of a pavement

clearance, lateral

the width required for safe passage as measured in a horizontal plane

clearance, vertical

the height required for safe passage as measured in a vertical plane

CMAQ

The Congestion Mitigation and Air Quality Improvement Program, a funding category in Title I of ISTEA that provides funds for projects and activities to reduce congestion and improve air quality

COG

Council of Governments; one of several possible names for a Metropolitan Planning Organization

collector (street)

a street designated to carry traffic between local streets and arterials, or from local street to local street

combined sewer

a wholly or partially piped system which is owned, operated, and maintained by a local municipality or sanitary district, and that is designed to carry sewage or drainage water

commercial load zone

a portion of a street designated by a sign and yellow paint markings, reserved for the exclusive use of vehicles with a valid commercial load zone permit

concrete

a hard, strong construction material made by mixing a binder such as portland cement or asphalt with a mineral aggregate (sand and gravel) so that the entire mass is bound together and hardened

CRAB

County Road Administration Board; an oversight agency for county road organizations; as part of that function, it administers the Rural Arterial and County Arterial preservation programs for the State

cross section

diagrammatic presentation of a highway profile at right angles to the centerline at a given location

crosswalk

portion of a roadway designated for pedestrian crossing, marked or unmarked; unmarked crosswalks are the natural extension of the shoulder, curb line or sidewalk

crosswalk

the marked or unmarked portion of the roadway designated for pedestrians to cross the street

crosswalk beacon

amber flashing lights, usually accompanied by a sign, used to notify motorists of a pedestrian crosswalk

CTR

commute trip reduction; legislation requires major employers in the eight most populous counties in the state to take measures to reduce the number of single-occupant vehicle trips and the number of vehicle miles traveled by their employees

cul de sac

a street closed at one end that is enlarged to provide turn around space for motor vehicles

culvert

a transverse drain under a roadway, canal, or embankment other than a bridge; most culverts are fabricated with materials such as corrugated metal and precast concrete pipe

curb

a rim along a street or roadway, an edge for a sidewalk; a curb is usually constructed from cement concrete, asphalt concrete, or granite; curbs create a physical barrier between the roadway and the planting strip, which provides a safer environment for pedestrians, and facilitates street drainage

curb bulb

an extension of the curb line into the roadway

curb cut

used to describe a depression in the curb to accommodate a driveway; where there is no curb, the point at which the driveway meets the roadway pavement is considered the curb cut

curb line

the edge of a roadway; it may or may not be marked by a curb

curb radius

refers to the degree of curvature of the curb at a corner; other conditions being equal, a large curb radius allows right-turning vehicles to turn more quickly than a small curb radius

curb ramp

the area of the sidewalk, usually at the intersection, that allows easy access/transition for wheelchairs, strollers, and other wheeled equipment, between the sidewalk and the street

DCD

Department of Community Development; state agency responsible for undertaking state duties arising from the Growth Management Act

DCLU

Department of Construction and Land Use

dead-end street

street-end formed when an existing right-of-way is not platted through from street to street, or when topography or other conditions preclude a street from being improved to its full length

DLCD

Department of Land Conservation and Development

DON

Department of Neighborhoods

DOT

Department of Transportation can refer to US DOT or a state DOT

drainage swale

a shallow, grassy drainage channel that accommodates surface water runoff; used on street without curbs and gutters

driveway

the portion of the street or alley area which provides vehicle access to an off-street area through a depression in the curb

EAC

Enhancement Advisory Committee; sets criteria for projects to receive funding from the Enhancements Program and recommends projects to WSDOT

effective sidewalk width

the width of the sidewalk area available for walking or wheelchair travel, unobstructed by street furniture or other impediments

EPA

Environmental Protection Agency; federal agency responsible for monitoring and ensuring compliance with air quality standards at the state level

ETC

employee transportation coordinator; businesses affected by CTR designate a staff person as an employee transportation coordinator to implement and coordinate the company's compliance with that law

FHWA

Federal Highway Administration; agency of the USDOT with jurisdiction over highways

fire lane

an area on public or private property reserved for providing fire department access to structures, fire-sighting fixtures or equipment

fog line

the white line at the outside edge of the motor vehicle travel lane, used to designate the boundary of the vehicle travel lane

frontage road

a road designated and designed to serve local traffic parallel and adjacent to a highway or arterial street

FTA

The Federal Transit Administration is the USDOT agency with jurisdiction over transit

GMA

Growth Management Act; requires all cities and counties in the state to do planning that addresses the negative consequences of population growth and suburban sprawl

grade

a measure of the steepness of a roadway, bikeway or walkway, expressed in a ratio of vertical rise per horizontal distance, usually in percent; e.g. a 5 percent grade equals 5 m of rise over a 100 m horizontal distance

grade separation

the vertical separation of conflicting travelways with a structure

grade-separated crossing

an interchange between roadways, railways, or pathways that provides for the movement of traffic on different levels

green time

the length of time a traffic signal indicates a green light

highway

a general term denoting a public way for purposes of travel, including the entire area within the right-of-way

HOV

high-occupancy vehicle; a car carrying enough people to be able to travel in the HOV/ diamond lane, or a vanpool or bus

inlet

an opening at the surface of the ground through which runoff water enters the drainage system

intersection

a place or area where two or more roads cross

ISTEA

Intermodal Surface Transportation Efficiency Act; 1991; implemented broad changes in the way transportation decisions are made by emphasizing diversity and balance of modes and preservation of existing systems over construction of new facilities

jaywalking

crossing a street illegally; includes walking against a traffic control device, or stepping out in front of a moving vehicle so as to present an immediate danger, whether in a crosswalk or not, or crossing at an intersection outside of a crosswalk

kiosk

a small freestanding structure either open or partially closed, where merchandise is displayed, advertised, or sold, or where notices are displayed

landmark

a building, structure or site that has historical or architectural significance, especially a structure designated as a landmark pursuant to the Landmarks Preservation Ordinance

landscape lighting

lighting that is designed to accompany and illuminate landscaping features

lane line

a solid or broken paint line or other marker separating lanes of traffic moving in the same direction

LCDC

Land Conservation and Development Commission

legend

works, phases or numbers appearing on all or part of a traffic control device; also the symbols that appear on maps

LID

Local Improvement District

load and unload zone

a portion of the street or alley, designated by a sign and white paint markings, reserved for picking up and dropping off people or property

local street

a street designated to provide access to and from residences or businesses

loop detector

a wire buried in the street and connected to a traffic signal allowing the signal to sense the presence of vehicle traffic

major truck street

a street designated to provide access to trucks with local and non-local destinations

marked crosswalk

any portion of the roadway distinctly indicated for pedestrian or bicycle crossing by lines, marking, or other traffic control devices

median

a physical barrier, or a solid yellow or cross hatched pavement marking at least 18" in width, which divides any street into two or more roadways

motor vehicle

a vehicle that is self-propelled or designed for self-propulsion

MPO

Metropolitan Planning Organization; the agency designated by the governor to administer the federally required transportation planning process in urban areas with a population over 50,000; the MPO is responsible for the 20-year long range plan and the Transportation Improvement Program

multi-use path

a path physically separated from motor vehicle traffic by an open space or barrier and either within a highway right-of-way or within an independent right-of-way, used by bicyclists, pedestrians, joggers, skaters and other non-motorized travelers

MUTCD

Manual on Uniform Traffic Control Devices; approved by the Federal Highway Administration as a national standard for placement and selection of all traffic control devices on or adjacent to all highways open to public travel

NHS

National Highway System; designated by Congress; contains all interstate routes, a

large percentage of urban and rural principal arterials, and strategic highways and connectors

NMF(P)

Neighborhood Matching Fund (Program); administered by the Department of Neighborhoods

off-street parking

publicly or privately owned parking located outside the street right-of-way

open space

land and/or water area with its surface open to the sky or predominantly undeveloped, which is set aside to serve the purposes of providing park and recreation opportunities, conserving valuable resources, and structuring urban development and form

pavement markings

painted or applied lines or legends placed on a roadway surface for regulating, guiding or warning traffic

pedestrian

a person on foot, in a wheelchair or walking a bicycle

pedestrian detectors

devices, usually push-button activated, that allow pedestrians or bicycles to change the signal light at a crosswalk

pedestrian facility

a facility provided for the benefit of pedestrian travel, including walkways, crosswalks, signs, signals, illumination and benches

pedestrian half signal

a traffic control signal often located at the junction of an arterial and a residential street, which provides pedestrian signals for crossing

the arterial but not for crossing the residential street

pedestrian overpass

a pedestrian walkway above the grade of the roadway, which allows pedestrians to cross the roadway without interacting with motor vehicles

pedestrian refuge island

a defined area between traffic lanes that provides a safe place for pedestrians to wait as they cross the street

pedestrian scale lighting

overhead street lighting which is typically over the sidewalk instead of the roadway, and at a lower height than typical street light fixtures; providing illumination for pedestrians instead of motorists

pedestrian signals

electronic devices used for controlling the movement of pedestrians at signalized mid-blocks or intersections, which may include the “walk/don’t walk” messages or the symbolic walking person/hand message

pedestrian walkway

a surfaced walkway, separated from the roadway, usually of crushed walk or asphalt concrete, and following the existing ground surface (not at permanent grade)

pedestrian-friendly

describing an environment that is pleasant and inviting for people to experience on foot; specifically, offering sensory appeal, safety, street amenities such as plantings and furniture, good lighting, easy visual and physical access to buildings, and diverse activities

planting strip

the street right-of-way area lying between the constructed curb and the sidewalk

principal arterial

a main traffic route which connects major activity centers, usually characterized by trip lengths of two miles or more

priority network

a comprehensive plan designation indicating the primary function(s) of a street; transit priority networks, major truck streets, and principal arterials

residential parking zone

a designated zone in which on-street parking for the general public is restricted. Residents of the area are exempted from the parking restrictions by permit

residential street

a non-arterial street that provides access to residential land uses, and connects to higher level traffic streets; also called residential access street

resurfacing

the placing of a new surface on an existing pavement to improve its conformation or to increase its strength

retaining wall

a structure used to sustain the pressure of the earth behind it

right-of-way

a strip of land platted, dedicated, condemned, established by prescription, or otherwise legally established for the use of pedestrians, vehicles or utilities; the legal right of one vehicle, bicycle, pedestrian or device to proceed in a lawful manner in preference to another vehicle, bicycle, pedestrian or device

roadway

the paved portion of the highway

RTA

Regional Transportation Authority; one of the agencies established by legislation which has the ability to provide high capacity transit

RTPO

Regional Transportation Planning Organizations; created by local governments to coordinate transportation planning among jurisdictions and to develop regional transportation plans

rules of the road

the portion of a motor vehicle law that contains regulations governing the operation of vehicular and pedestrian traffic

sandwich boards

stand-up A-shaped signs often placed on the sidewalk or street right-of-way to advertise a business or an attraction

sanitary sewer

a piped system which is owned, operated, and maintained by a local municipality or sanitary district, and that is designed to carry only sewage

school crossing

a crossing adjacent to a school or on established school pedestrian routes, designated as a preferred crossing for school users

school zone

an established reduced speed area; installed around established school crossing; speed limits are posted at 20 mph

SED

Seattle Engineering Department

SEPA

State Environmental Policy Act; requires the evaluation of environmental impacts associated with a project or agency action prior to approval

service lane

the curb lane that provides access to businesses for service vehicles

setback

the required or actual placement of a building a specified distance away from a road, property line, or other structures

shared roadway

a type of bikeway where bicyclists and motor vehicles share a travel lane

shoulder

the paved or unpaved area between the roadway edge and the property line; contiguous to the travel lanes; provided for pedestrians, bicyclists, emergency use by vehicles and for lateral support of base and surface courses

shoulder bikeway

a type of bikeway where bicyclists travel on a paved shoulder

shy distance

the distance between the edge of a travelway and a fixed object

side sewer

a privately owned system for transporting and disposing of drainage water and sewage

sidewalk

a walkway separated from the roadway with a curb, constructed of a durable, hard and smooth surface, designed for preferential or exclusive use by pedestrians

sidewalk, concrete

the improved portion of a street or roadway between the curb lines and the adjacent property lines, intended for use by pedestrians

sight distance

the length of roadway visible to a driver; the distance a person can see along an unobstructed line of sight

signal timing

the green time allotted each direction of travel;
the time between start of green for adjacent/ sequential traffic signals

signs

provide information to motorists, pedestrians and bicyclists; black and white regulatory signs provide information on legal requirements; black and yellow warning signs advise about potentially hazardous roadway conditions; green or white guide/destination signs provide navigational information along streets, and inform about intersecting routes and important destination

skew angle

the angle formed between a roadway, bikeway or walkway and an intersecting roadway, bikeway, walkway or railway, measured away from the perpendicular

slope

ground that forms a natural or artificial incline

slope line

the line where the graded portion of the roadway from the center line toward the edge changes to the transition slope required to meet the surface of the abutting private property

SOV

single-occupancy vehicle

staired street

street rights-of-way on hillsides which have been developed as stairs for pedestrians, not roadways for motor vehicle use

STIP

Statewide Transportation Improvement Program; a three-year transportation investment strategy which addresses the goals of the state long-range plan and lists priority projects and activities throughout the state

stop bar

a painted stripe across a traffic lane to indicate where vehicles should stop at a stop sign or a traffic signal

storm drain

a system of gutters, pipes or ditches used to carry storm water from surrounding lands to streams and lakes, and larger bodies of water

STP

Surface Transportation Program; one of the key capital programs in Title I of ISTEA; it provides flexibility in expenditure of road funds for nonmotorized and transit modes and for a category of activities known as transportation enhancements

street furniture

accessories and amenities placed on sidewalks for the convenience and accommodation of pedestrians; these may include such things as benches or other seating, trash receptacles, drinking fountains, planter, kiosks, clocks, newspaper dispensers, or telephones

street improvement

an improvement in the public right-of-way, whether above or below ground, such as

pavement, sidewalks, or a storm water drainage system

street tree

a tree planted within public right-of-way

street tree grates

grates, usually metal and often decorative, that cover street tree pits and allow air and water to reach the soil

street tree pits

cutouts from a sidewalk or paved planting strip, to allow air and water to reach the trees planted in the cutout

street-end

formed where an existing right-of-way ends or is not platted through from street to street, often due to topographical conditions (such as bluffs or shorelines)

streetscape

the visual character of a street as determined by elements such as structures, greenery, driveways, open space, view, and other natural and man-made components

structure

a bridge, retaining wall or tunnel

Symms

National Recreational Trail Funds; Symms after the Senator; for recreational trails or related projects

T-intersection

the meeting of two streets, usually perpendicular, where one of the streets does not continue through; approximately resembling the letter “t”

TDM

Transportation Demand Management; measures attempt to reduce the proportion of trips made by SOV

TEA

Transportation Enhancement Activities; the percent of the STP funds for Transportation Enhancement Activities (bike facilities, landscaping, etc)

TIP

Transportation Improvement Program; a three-year investment strategy required under ISTEA which addresses the goals of the long-range plans and lists priority projects for the region

TMA

Transportation Management Association; voluntary groups set up to manage and reduce the number of trips taken in an area; these associations are frequently created and managed by employees; subject to special requirements under ISTEA and in some cases benefit from preferential treatment with regard to air quality needs and local authority to select transportation projects; any urban area over 200,000 population is automatically a TMA

traffic actuated signal

a signal that responds to the presence of a vehicle or pedestrian (for motor vehicles, loop detectors; for pedestrians, usually push buttons)

traffic calming

of or relating to transportation techniques, programs, or facilities intended to slow the movement of motor vehicles

traffic control device

any sign, signal, marking, or device placed or erected for the purpose of regulating, warning,

or guiding vehicle traffic and/or nonmotorized traffic

traffic signal

any traffic device, whether manually, electrically or mechanically operate, which assigns right-of-way to vehicles and pedestrians at intersections

traffic volume

the given number of vehicles that pass a given point for a given amount of time (hour, day, year); see “ADT”

transit priority network

consisting of those streets and highways that carry local and regional transit trips, as designated in Seattle’s comprehensive plan

transit stop or transit station

a regular stopping place on a transit route that may include transit shelter and parking

travel lane

roadway lanes on which traffic moves

TSP

Transportation System Plan; the overall plan for all transportation modes for a given area (usually city, county or MPO)

two-way left turn lane

a lane near the center of the roadway set aside for use by vehicles making left turns in both directions from or into the roadway

UGB

Urban Growth Boundary; the area surrounding an incorporated city in which the city may legally expand its city limits

uncontrolled intersection

an intersection where the right-of-way is not controlled by a stop sign, yield sign, or traffic signal

urban area

the area immediately surrounding an incorporated city or rural community that is urban in character, regardless of size

urban trails

off-road trails, special bike lanes, and signed routes in the street right-of-way

utility poles

poles used to carry utility wires, such as electric, cable television, telephone, or electrified trolley wire; may belong to Metro, telephone companies, power companies, or any combination of these

vehicle

any device in, upon or by which any person or property is or may be transported or drawn upon a highway, including vehicles that are self-propelled or powered by any means

VMT

vehicle miles traveled; describes the number of miles traveled during a typical trip, i.e., a commute trip; it can serve as an indicator for TDM activities

walkway

a transportation facility built for use by pedestrians, including persons in wheelchairs; walkways include sidewalks, paths and paved shoulders

wide outside lane

a wider than normal curbside travel lane that is provided for ease of bicycle operation where there is insufficient room for a bike lane or shoulder bikeway

WSDOT

Washington State Department of Transportation

Index

- access to transit 107, 176-183
- access management (and traffic regulation) 106-108, 131
- accessible building entrances 189, 193
- accessible routes of travel 35, 187-188
 - as connecting routes through sites 46
- accessibility 33-47
 - clear travel area at intersections 119
 - clearances 37
 - eliminating barriers and obstacles 35-37
 - levels of accessibility on recreational trails 69-70
 - requirements, summarized 47
 - sidewalks and walkways 87-89
 - signing and other communication aids 46
 - surfacing treatments 45
 - textural and visual cues 45
 - trails and pathways 68-70
 - walkways and accessible routes of travel 187-188
 - widths of accessible travel ways 37
- ADA (see Americans with Disabilities Act)
- advance warning signs:
 - in school zones; prior to school bus stops 62, 63
 - prior to intersections and mid-block crossings 123, 149
- advisory group/reviewers 3, 4
- aids to pedestrians 15-16
 - older pedestrians 15
 - people with disabilities 15,16
- Americans with Disabilities Act (ADA) 33-34 (also see accessibility, above)
- artwork (in pedestrian environments) 183
- barriers and obstacles (eliminating them) 35-37
- barriers (concrete/New Jersey) 97
- bicycles/bikes on sidewalks 104-105
- bike lanes (as separation between pedestrians and vehicles) 97
- boardwalks and trestles 157-158
- bollards - design and placement of on trails and pathways 79
- bridges (see overpasses and bridges)
- building frontage zone (of urban sidewalk) 101
- building location and design 193
- bus shelters, covered walkways 178, 188, 202
- bus stops/zones:

Index

- access to, as part of site design 186, 191
- schools 56-57
- transit 177-181
- chicanes 164, 168
- children 10-11, 14, 49-65
- clearances:
 - clear travel areas at intersections 119
 - lateral clearances along multi-use trails and pathways; sidewalks/
walkways 75, 97-99
 - related to accessible travel 37
 - related to utilities/furnishings 97-98
 - vertical clearances along sidewalks/walkways and trails/pathways 75,
- collisions (involving pedestrians and vehicles):
 - common characteristics of 10
 - common types of collisions involving children (aged K-6) 49
 - fatalities (based on speed of vehicle) 10
 - statistics for children and older adults 11
- colored paving (colored/textured) at intersections 139
- concrete (New Jersey) barriers 97
- covered walkways 178
 - in work zones 202
- cross slopes 38, 77, 90
- crossing distance (reducing/minimizing):
 - at intersections 123-129, 133 (crossing distance related to speed and
time)
 - curb bulb-outs/extensions 128-129
 - medians and center refuge islands 127-128
 - right-turn channelization lane with refuge island (slip lane) 125-127
 - skewed and multiple intersections (avoiding and reconfiguring) 129
 - through curb return radius reduction/shortening 123-125
- crossing guards and student patrols at crossings 61-62
- crossings 141-159
 - boardwalks and trestles 157-158
 - fencing, barriers, signs, landscaping, etc. to channelize
pedestrians 150-151
 - flashing beacons at mid-block 148-149
 - grade separated crossings 152-156
 - marked crosswalks at mid-block 143-145
 - medians and center refuge islands at 127-128, 145-148
 - markings (see crosswalks)
 - mid-block crossings 141-151
 - multi-use trails and pathways - street crossings 156-157
 - overpasses and bridges 153-155
 - portable pedestrian flags at 150-151
 - railroad crossings 151-152

- raised mid-block crossings 148
- signing at intersections 123
- signing at mid-block crossings 149
- street lighting at mid-block 150
- underpasses and tunnels 156
- crosswalks:
 - at signalized locations (school areas) 60
 - determining the need for marked crosswalks/crossing treatments at intersections 116
 - dimensions of 119-120
 - effectiveness of marked crosswalks/crossing treatments at intersections 115
 - guidelines for installation of crosswalk markings 117-119
 - marked crosswalks at mid-block crossings 143-145
 - marked crosswalks in school zones/along school walk routes 59
 - marked crosswalks vs. unmarked 59, 116-119
 - markings/stripping, types of 120-122
 - dashed crosswalk markings 121
 - horizontal bar crosswalk markings 120-121
 - ladder bar crosswalk markings 120-121
 - piano crosswalk markings 120-121
 - solid crosswalk markings 121
 - zebra crosswalk markings 120-121
 - raised pavement markers/rumble strips in advance of 122
 - stop bars 120, 122
 - stop-controlled crosswalks (school areas) 60
 - use of crosswalks at intersections 115
- cul-de-sac/street closures 165, 169
- curb (vertical) 94-95
 - extruded curbing 95
 - rolled curbing (strongly discouraged) 95
 - timber curbing 95
- curb and gutter 94-95
- curb extensions/bulb-outs (chokers, neck-downs):
 - as traffic calming tools 164, 169
 - at intersections 128-129
- curb radius reduction/shortening at intersections to minimize crossing distance 123-125
 - benefits and disadvantages of curb radius shortening 125
- curb ramp (sidewalk curb ramp) 39-43
 - curb ramps for accessibility at intersections 41-43
 - curb ramps at intersections 122
- dashed (European) crosswalk markings 121
- design:
 - definition of 2

Index

- importance of good design 24-25
- design for people with disabilities 34
- design for older adults 34
- design for children 49, 50
- design toolkit 22-204
- diagonal diverters (traffic calming device) 165, 169
- dimensions of:
 - accessible facilities 37-38, 40, 47
 - building frontage zone (of sidewalk) 101
 - crosswalks 119-120
 - curb ramps (sidewalk) 40
 - curbing placement 96
 - handrails 43
 - medians and refuge islands 126, 147
 - on-street parking setbacks (recommended) 130
 - overhead crossings 155
 - parking overhangs 106
 - passing, waiting and resting areas 89
 - pavement cross sections for trails 76
 - pedestrian travel zone (of sidewalk) 101
 - planting buffers/planting zones 88, 92-93, 101-102, 190
 - railings 78
 - school bus stops 56-57
 - separation between road and multi-use pathway 73
 - sidewalks and walkways 88-89 (see table page 89)
 - shoulders (walking shoulders) 103-104
 - spatial dimensions of pedestrians 13-16
 - speed humps 170-171
 - stairway/steps treads and risers 195
 - traffic circles 167
 - trails and pathways 70-75 (see table page 75)
 - transit stops 177-180
 - underpasses 157
- ditches/swales (as separation treatments) 94
- drainage/drainage inlets and grates 77, 90, 122
- driveways/driveway design 43-45, 106-108, 188-191
 - access management and driveways 106-108
 - considerations related to accessibility 43-45
 - wide planting areas at driveways (benefits for pedestrians) 190
- driveway design comparisons (best conditions for pedestrians) 189
- dual turning movements at intersections 135
- edge/separation treatments 92-97
 - bike lanes as separation 97
 - concrete (New Jersey) barriers 97
 - curb and gutter/vertical curb 94-95

- ditches/swales as separation 94
- extruded and timber curbing 95-96
- planting buffers 92-94
- raised pavement markers 96-97
- rolled curb (strongly discouraged) 95
- extruded curb/curbing 95
- fatalities (for pedestrians, based on vehicle speeds) 10
- fixtures/planting zone (of urban sidewalks) 102
- fencing, barriers, signs, landscaping, etc. to channelize pedestrians
 - at mid-block crossings 150-151
- flashing beacons:
 - at mid-block locations 148-149
 - at school crossings 60-61
- forecasting pedestrian use/travel 19
 - assessing the need for pedestrian facilities 20
- forced turns and partial diverters (traffic calming device) 165
- full street closure (as a traffic calming technique) 165, 169
- glossary 215-226
- grades (longitudinal) 38, 77, 90
- grade separation/grade separated crossings 61, 136, 152-156
 - at intersections (minimizing conflicts with motor vehicles) 136
 - determining the need for 152-153
 - in school areas 61
 - overpasses and bridges 153-155
 - underpasses and tunnels 156
- guidebook users, anticipated 2
- guidelines, others to reference 5, 6
- handrails 43
- horizontal bar crosswalk markings 120-121
- increasing pedestrian travel:
 - through installation of pedestrian facilities 17-20
 - through mixed use development 198
 - through transit/bus stop improvements 177-179
- innovative techniques:
 - alternative color school signs 63
 - portable pedestrian flags 150-151
 - PUFFIN and PELICON devices 150
 - soft sandwich signs 150
- interchanges (freeway) and expressway ramps 135-136
- intersections 113-140
 - basic principles of intersection design to accommodate pedestrians 114
 - clear travel area for pedestrians at 119
 - common design practices for pedestrian crossings at 114-123
 - crossing treatments, design of 115-122
 - crosswalk dimensions 119-120

Index

- crosswalk markings at intersections 115-122
 - (see page references for specific types of markings under “crosswalks”)
 - curb ramps at 122
 - determining the need for crossing treatments at intersections 116
 - drainage inlets and grates at intersections 122
 - effects of pedestrian improvements on vehicle capacity at 114
 - grade separation (minimizing conflicts with motor vehicles) 136
 - interchanges (freeway) and expressway ramps 135-136
 - lighting at 122
 - marked vs. unmarked crosswalks at intersections 116-119
 - medians and refuge islands at intersections 125-128
 - minimizing crossing distances at intersections 123-129
 - (see page references for specific techniques under “crossing distance”)
 - minimizing pedestrian/motor vehicle conflicts at 129-139
 - multi-use trails and pathways intersections and street crossings 156-157
 - raised pavement markers/rumble strips in advance of 122
 - signs related to pedestrian crossings at intersections 123
 - stop bars at 120, 122
 - turning movements/conflicts 134-135
 - traffic circles vs. roundabouts at intersections 136-138
 - uncontrolled, guidelines for installation of marked crosswalks at 118
- ladder bar crosswalk markings 120-121
- landings 38, 42
- landscaping, vegetation, and furnishings:
 - along trails and pathways 79
 - as part of site design 194
 - landscaping and street trees along sidewalks 99
 - root barriers (adjacent to sidewalks/walkways; trails/pathways) 80
- land use/mixed use site development 198
- lighting (see also street lighting):
 - accessibility requirements 46
 - along streets sidewalks 100
 - at intersections 122
 - at mid-block crossings (under design considerations) 150
 - along trails and pathways 80
- maintenance:
 - in school zones 64
 - in work zones 204
 - of trails and pathways 80
 - of sidewalks and walkways 109-110
- marked crosswalks:
 - at mid-block 143-145
 - guidelines for the installation of 117-119
 - dimensions 119-120

- effectiveness and use of 115
- in school areas 59
- versus unmarked at intersections 116-119
- stop bars 120, 122
- types of markings 120-122
 - dashed crosswalk markings 121
 - horizontal bar crosswalk markings 120-121
 - ladder bar crosswalk markings 120-121
 - piano crosswalk markings 120-121
 - solid crosswalk markings 121
 - zebra crosswalk markings 120-121
- meandering walkways 94
- medians and refuge islands:
 - at intersections 127-128
 - at mid-block crossings 145-148
 - design guidelines for 147
 - traffic calming benefits of 168
- mid-block crossings 141-151
 - advanced warning signs and pedestrian crossing signs at 149
 - design of 143-151
 - determining the need for 142-143
 - fencing, barriers, signs, landscaping, sidewalk ramps to channelize pedestrians at mid-block 150-151
 - flashing beacons at 148-149
 - marked crosswalks at 143-145
 - medians and refuge islands at 145-148
 - pedestrian actuated signals at 145
 - PUFFIN and PELICON devices at 150
 - raised crossings at 148
 - soft sandwich at 150
 - street lighting at mid-block (under design considerations) 150
- mixed use development 198
 - checklist for successful mixed use 198
- motor vehicles, minimizing conflicts with at intersections 129-139
 - interchanges (freeways) and expressway ramps 135-136
 - crossing distances, speeds and times 133
 - grade separation 61, 136, 152-156
 - on-street parking restrictions near intersections 130-131
 - sight distance at intersection corners 129
 - signalization at intersections 131-135
 - traffic regulation and access management 131
 - turning movements/conflicts 134-135
 - visibility and sight distance 129-131
- multiple intersections (avoiding and reconfiguring) 129
- multi-use trails and pathways (see also trails and pathways):

Index

- delineation/separation treatments on 71,72
- intersections and crossings 156
- minimizing conflicts between users 70-72
- next to roadways 72
- separation from roadways 72-75
- narrowed streets (traffic calming approach) 165, 167-168
- needs of pedestrians 11-16
- neighborhood gateways (traffic calming approach) 166, 172
- neighborhood traffic calming/management 27, 162-173
- New Jersey concrete barriers 97
- on-site circulation and parking 191-192
- one-way streets (considerations for pedestrians) 107-109
- one-way entry/exit (traffic calming device) 165
- overhead crossings (see overpasses and bridges)
- overhead signs at crossings 149
- overpasses and bridges 153-155
 - aesthetics 153
 - design load 153-154
 - geometry 154
 - safety 154
 - skywalks and skyways 154-155
 - structure selection 153
- parabolic speed hump 171
- parking along streets (as buffer for pedestrians) 105-106
- parking setbacks (recommended on-street parking setbacks) for sight distance 130-131
- park and ride facilities (access to) 181
- partial street closures/diverters 165, 169
- passing, waiting, and resting areas 37, 89
- pathways (see trails and pathways)
- pavement cross sections for trails 76
- pavement markings (school zones) 63-64
- pavement texture patterns 192-193
- paving and surfacing (trails and pathways) 76, 79 (thickened-edges)
- pedestrians:
 - about pedestrians/characteristics of 9-20
 - collision statistics (see collisions)
 - needs of 11-16
 - spatial considerations/needs 13
- pedestrian access to transit 176-183
- pedestrian actuated signals/actuators:
 - at intersections 132-133
 - at mid-block 145
 - crossing distances, speeds and times 133
 - measures to improve the effectiveness of push buttons 132

- signal timing 133
 - WALK signal timing 134
- pedestrian characteristics by age group 14
- pedestrian comforts and support facilities 182-183, 197
- pedestrian detectors (see pedestrian actuated signals/actuators)
- pedestrian facility/facilities:
 - defined 2, 24
 - assessing the need for 20, 84-85 (sidewalks)
- pedestrian flags (portable) 150-151
- pedestrian friendly:
 - communities 26-27
 - schools and school zones 53-54
 - site design/development 185-199
 - shopping centers 187
 - streets 30-31, 97-100
- pedestrian friendly site design checklist 186
- pedestrian half signal (see signals/signalized crossings)
- pedestrian needs 11-16
 - needs of children and older adults 14
 - spatial needs 13
- pedestrian overpass (see overpasses and bridges; grade separation)
- pedestrian plazas 195, 197
- pedestrian refuge island (see refuge islands and medians)
- pedestrian safety 9-11
 - ITE criteria for determining pedestrian safety deficiencies 85
- pedestrian scale 193
- pedestrian signals (see signals/signalized crossings)
- pedestrian systems:
 - community 28
 - effective 28-29
- pedestrian travel/trips:
 - common reasons for low levels of pedestrian travel 19
 - increasing through installation of pedestrian facilities and improvements 17-20
 - increasing through mixed use development 198
 - increasing through transit/bus stop improvements 177-179
 - studies on 18-19
 - travel characteristics 16-19
 - types of trips 17, 18
 - walking speeds/travel speeds 133
- pedestrian travel zone (of urban sidewalks) 101-102
- pedestrian underpass (see underpasses and tunnels; grade separation)
- piano crosswalk markings 120-121
- planting buffers (as separation) 92-94
 - advantages and disadvantages of 92

Index

- planting/fixtures zone (of urban sidewalks) 102
- plazas 195, 197
- policy for encouraging pedestrian travel (Washington State) 25
- portable pedestrian flags 150-151
- protective barriers 202
- PUFFIN and PELICON devices at crossings 150
- railings:
 - accessibility requirements 38-43
 - adjacent to trails and pathways 77-78
 - adjacent to sidewalks and walkways 90-91
 - handrails 43
- railroad crossings 151-152
 - angle of crossing 152
 - crossing design options 151
 - signing and marking at 152
 - surface smoothness at 152
- raised crossings/crosswalks 172
 - at mid-block 148
- raised intersections 138-139, 169-170
- raised pavement markers:
 - as separation 96-97
 - prior to intersection crossings 122
- ramps (longitudinal) 38, 39
- ramps, stairways, and steps 194-196
- reduced curb return radius (to minimize crossing distances at intersections) 123-125
- reduced speed zones 58
- refuge islands:
 - as traffic calming tools 168
 - at intersections 127-128
 - at mid-block crossings 145-148
 - at right-turn channelization lanes (slip lanes) 125-127
 - design guidelines for 147
- residential traffic management 162-163
- resource guide 205-214
- resting areas (along sidewalks and walkways) 89
- retaining walls (along sidewalks and walkways) 90-91
- right-turn channelization lanes (slip lanes) with refuge islands 125-127
- rolled curb/curbing (strongly discouraged) 95
- root barriers (adjacent to sidewalks/walkways; trails/pathways) 80
- roundabouts (comparisons with traffic calming circles) 136-138
- safety in work zones 201-204
 - considerations for pedestrian safety 202
 - covered walkways 202
 - fencing around work zones 201

- intersections and crossings near work zones 203
- maintenance in work zones 204
- protective barriers 202
- sidewalk closure during construction 202
- temporary pedestrian routes around work zones 203
- sandwich board signs (see soft sandwich)
- schools/school zones; school crossings and crosswalks 50-65
 - access routes to school 54
 - crossing guard and student patrolled crosswalks 61-62
 - elements of good school site design 53
 - maintenance in school zones 64-65
 - marked crosswalks in 59
 - roadside improvements along school walk routes 55-56
 - school as a community focal point 52
 - school bus stop design 56-57
 - school sign test program 63
 - signing and marking in 62-64
 - traffic control and crossings near schools 57-64
 - visibility at crossings and along school walk routes 57
- school site design example 54
- school walk routes 54-64
 - procedures for developing 64
 - safety programs 64
 - visibility at crossings and along school walk routes 57
- seasonal and nighttime use of trails and pathways 80
- separation/edge treatments (adjacent to pedestrian travel ways) 92-97
 - bike lanes as separation 97
 - concrete (New Jersey) barriers 97
 - curb and gutter/vertical curb 94-95
 - ditches/swales as separation 94
 - extruded and timber curbing 95-96
 - planting buffers 92-94
 - raised pavement markers 96-97
 - rolled curb (strongly discouraged) 95
- shared parking lots 192
- shoulders as walkways (walkway shoulders/shoulder walkways) 55, 102-104
 - as walkways in rural areas 102-104
 - operational considerations 104
 - recommended shoulder dimensions 103
 - shoulder surfacing and delineation 103
- side slopes 77-78, 90-91,
- sidewalks (and walkways) 83-111
 - accessible/nonaccessible 54, 55
 - clearances 98-99
 - closure during construction 202

Index

- curb ramps 39-43
 - defined 86
 - dimensions (recommended) 86, 88-89
 - grades, cross slope and drainage 90
 - in central business districts (CBDs) and downtowns 100-102
 - in various settings (design treatments for) 85
 - location - both sides vs. one side 87
 - maintenance of 109-110
 - passing, waiting and resting areas along sidewalks 89
 - priorities for pedestrians traveling along streets 83
 - side slopes, railings and walls along sidewalks 90-91
 - signing along sidewalks and walkways 100
 - surfacing treatments 91-92
 - when and where needed 84-85
 - width/dimensions 86
- sight distance (see visibility/visual clearance/sight distance)
- signals/signalized crossings 60
 - crossing distances, speeds and times 133
 - mid-block pedestrian actuated signals 145
 - pedestrian actuated signals 132
 - pedestrian indications 131-132
 - push-buttons (actuators/detectors) 132-134
- signal timing 133-134
- signs/signage 46, 166, 172
 - advanced warning signs and pedestrian crossing signs at mid-block 149
 - along streets and sidewalks 100
 - soft sandwich signs 150
- site design for pedestrians 185-199
 - thinking about pedestrians as part of site design 186
 - to facilitate access to transit 191
- sites used exclusively by pedestrians 195, 197
- skewed intersections (avoiding and reconfiguring) 129
- skywalks and skyways 154-155
- slopes (see cross slopes, grades, and side slopes)
- soft sandwich signs at crossings 150
- solid crosswalk markings 121
- spatial needs 13
- special paving:
 - at intersections 139
 - traffic calming tool 166
- speed humps/speed tables (traffic calming devices) 165, 170-172
 - city of Bellevue speed hump design 171
 - parabolic speed hump 171
 - raised crosswalk/speed table 172
- speed watch programs (traffic calming approach) 166

- stairs and steps 194-195
 - height between landings 195
 - landing dimensions
 - stairway width 195
 - step dimensions 195
 - tread design 195
 - tread to riser ratio 195
- standards, others to reference 5, 6
- state highways (pedestrian access along) 108-109
 - as main streets 108
 - as connectors between towns and cities 109
- stopping distances related to speed/pedestrian collisions 10-11
- street design (with the pedestrian in mind) 105-109
 - access management and driveway placement/design 106-108
 - access to transit 107
 - bike lanes as separation/buffer between pedestrians and vehicles 97
 - on-street parking as buffer for pedestrians 105-106
 - on-street parking setback requirements 130-131
 - one-way streets - benefits and disadvantages for pedestrians 107-109
 - parking along streets 105-106
 - priorities for pedestrians travelling along streets 83
 - separation treatments (between pedestrian travel way and street) 92-97
 - street furnishings 97-98
 - street trees 99
 - (see also: pedestrian friendly - streets)
- street furniture 97-98, 194
- street lighting:
 - along streets/sidewalks 100
 - at intersections 122
 - at mid-block (under design considerations) 150
- street trees and landscaping along sidewalks 99
- student patrols and crossing guards at crossings 61-62
- student pedestrians 50-65
 - improving student pedestrian safety - a cooperative process 50-51
 - school related pedestrian facilities 51-64
- studies on pedestrian travel 18-19
 - Harris Poll (1990) 19
 - National Biking and Walking Study (1993) 18-19
 - University of Washington (Vernez-Moudon 1997) 18,
 - Youth Link Transportation Survey (City of Bellevue 1992) 19
- surfacing treatments:
 - accessible travel ways 45
 - trails and pathways 76
 - sidewalks and walkways 91-92
- textural/visual cues 45

Index

- textured or colored paving at intersections 139
- thickened-edge pavement design (along trails and pathways) 79
- traffic calming 58-59, 161-173
 - in school areas 58-59
 - purpose of 162
- traffic calming and management methods 163-173
 - common residential traffic management program actions 164
 - common types of traffic calming methods 164-166
- traffic calming circles 58-59, 136-138, 164, 166-167
- traffic control devices 131-136
- traffic regulation (access management) 131
- trails and pathways 67-81
 - accessibility of 68-69
 - across multiple jurisdictions 67
 - bollard design and placement along 79
 - connections and crossings 78
 - crossings/intersections with streets 156-157
 - dimensions (recommended) 74-75
 - grades, cross slopes and drainage 77
 - levels of accessibility on recreational trails 69-70
 - maintenance 80
 - managing motor vehicle access 78-79
 - multi-use, considerations for 70-75
 - paving and surfacing 76
 - recreational trails, design guidelines for 70
 - regional connectivity 68
 - seasonal and nighttime use of trails and pathways 80
 - shoulders, side slopes, railings along 77-78
 - split-pathway entrance 80
 - thickened-edge pavement design 79
- transit (access to) 176-183
 - as part of street design 107
 - coordination between agencies 183
- transit centers 181
- transit compatible design 176
- transit facilities for pedestrians:
 - how to improve transit facilities 177-179
 - increasing pedestrian access 177-179
 - low cost improvements 179
- transit malls 182
- transit/bus shelters and covered walkways 178, 202
 - artwork at 183
 - lighting at 182
 - pedestrian comfort at 182-183
 - security at 182

- transit stops and bus pullouts 177-181
 - ADA requirements at bus stops 178
 - same corner bus stop locations 180
 - typical bus stop cross section 177
 - widened sidewalk in bus loading area 177
- travel characteristics (of pedestrians) 16-19
 - types of trips 17, 18
 - common reasons for low levels of pedestrian travel 19
 - studies on pedestrian travel 18-19
- trips (types of pedestrian trips) 17, 18
- tunnels (see underpasses and tunnels)
- turning conflicts (reducing) 135
- turning-movements at intersections:
 - dual turning movements/two-way left-turns 135
 - reduced turning conflicts 135
 - regulating at intersections 134-135
- uncontrolled intersection:
 - guidelines for installation of marked crosswalks at 118
- underpasses and tunnels 156
 - geometry 156
 - safety 156
- urban areas (pedestrian facilities in) 16-17
- urban streetside zones (sidewalks in urban areas) 101-102
 - building frontage zone 101
 - fixtures planting zone 102
 - pedestrian travel zone 101-102
- urban trails (see trails and pathways)
- utilities (where to locate)
 - related clearances 97
 - located in planting buffers 93
- vegetation/landscaping (see landscaping)
- vehicle speed (as a factor in pedestrian collisions) 10-11
- visibility/visual clearance/sight distance:
 - at crossings and along school walk routes 57
 - at intersections 129-134
 - on-street parking restrictions 130-131
 - recommended parking setback for sight distance 130
- waiting areas (along sidewalks/walkways) 89
- walking distances (acceptable) 12
- walking speeds 12
 - related to crossing distance/time of crossing 133
- walkways (see also sidewalks):
 - defined 86-87
 - dimensions (recommended) 87
 - maintenance of 109-110

Index

- meandering walkways 94
- shoulders as walkways in rural areas/shoulder design
 - treatments 102-104
- sidewalks and walkways (design toolkit) 83-111
- walls (along sidewalks and walkways) 90-91
- Washington State Transportation Policy Plan (1994) 1
- Washington State Bicycle Transportation and Pedestrian Walkways Plan (1995) 3
- widths/dimensions (also see dimensions)
 - of accessible pedestrian travel ways 37
- work zones:
 - considerations for pedestrian safety in 202
 - covered walkways 202
 - fencing around 201
 - intersections and crossings near 203
 - maintenances in 204
 - protective barriers in 202
 - safety in 201-204
 - sidewalk closure during construction 202
 - temporary pedestrian routes around 203
- zebra crosswalk markings 120-121

Pedestrian Facilities Guidebook

Metric to English Conversion Chart

During the service life of this guidebook, use of the metric system in the United States is expected to expand. The following common factors represent the appropriate magnitude of conversion. The quantities given in U.S. customary units in the text, tables, or figures, represent a precision level that, in practice, typically does not exceed two significant figures. In making conversions, it is important not to falsely imply a greater accuracy in the product than existed in the original dimensions or quantity. However, certain applications such as surveying, structures, curve offset calculations, etc. may require great precision. Conversions for such purposes are given in parentheses

Length

25.40	mm (millimeters - 25.40)	=	1 inch
2.54	cm (centimeters - 2.54)	=	1 inch
0.30	m (meters - 0.3048)	=	1 foot
0.61	m (meters - 0.6096)	=	2 feet
0.91	m (meters - 0.9144)	=	3 feet
1.22	m (meters - 1.2192)	=	4 feet
1.52	m (meters - 1.524)	=	5 feet
1.83	m (meters - 1.8288)	=	6 feet
2.13	m (meters - 2.1336)	=	7 feet
2.44	m (meters - 2.4384)	=	8 feet
2.74	m (meters - 2.7432)	=	9 feet
3.05	m (meters - 3.048)	=	10 feet
6.10	m (meters - 6.096)	=	20 feet
15.24	m (meters - 15.24)	=	50 feet
30.48	m (meters - 30.48)	=	100 feet
0.91	m (meters - 0.9144)	=	1 yard
1.60	km (kilometers - 1.61)	=	1 mile

Volume

16.39	cm ³ (16.87)	=	1 cubic inch
0.03	m ³ (0.02832)	=	1 cubic foot
0.77	m ³ (0.7646)	=	1 cubic yard
0.95	L (liter - 0.9464)	=	1 quart
3.79	L (liter - 3.785)	=	1 gallon

Speed

0.31	ms (0.3048)	=	foot/sec.
1.61	km/h (1.609)	=	miles/hour

Area

0.09	m ² (0.0929)	=	1 square foot
0.84	m ² (0.836)	=	1 square yard

Light

11.0	lux (lumens per m ² - 10.8)	=	1 footcandle
------	--	---	--------------

For other units refer to the American Society of Testing Materials (1916 Race Street, Philadelphia, PA 19103) Standard for Metric Practice E 380.

Source: *ITE Pedestrian Design and Safety of Pedestrian Facilities*, adapted for use in this guidebook

Pedestrian Facilities Guidebook

Comment Request Form

Your input will be a valuable resource for future updates of the Pedestrian Facilities Guidebook!

Was the Guidebook easy to read and was it easy to find the information you need? (If not, please explain why and provide suggestions for improvements.)

Please suggest topics/issues to be covered in future updates of the Guidebook, including areas that weren't addressed to the level of detail that you were looking for, as well as new areas.

Please describe any information in the Guidebook you feel should be modified or deleted and discuss why.

Is there information that you think needs to be clarified? (Please attach marked copies of the Guidebook.)

Any other comments or suggestions?

Which Toolkit Sections Have You Reviewed and Found to be Most Useful?

- | | | | |
|--------------------------|-------------------------------------|--------------------------|--|
| <input type="checkbox"/> | Toolkit 1 General Design Guidelines | <input type="checkbox"/> | Toolkit 7 Crossings |
| <input type="checkbox"/> | Toolkit 2 Accessibility | <input type="checkbox"/> | Toolkit 8 Traffic Calming |
| <input type="checkbox"/> | Toolkit 3 Children and School Zones | <input type="checkbox"/> | Toolkit 9 Pedestrian Access to Transit |
| <input type="checkbox"/> | Toolkit 4 Trails and Pathways | <input type="checkbox"/> | Toolkit 10 Site Design for Pedestrians |
| <input type="checkbox"/> | Toolkit 5 Sidewalks and Walkways | <input type="checkbox"/> | Toolkit 11 Safety in Work Zones |
| <input type="checkbox"/> | Toolkit 6 Intersections | | |

Thanks for the Input!

Date: _____
Name (Optional): _____
Occupation/Position: _____
Address: _____
Phone: _____

Please mail this completed form to:

Bicycle and Pedestrian Program
Washington State Department of
Transportation
P.O. Box 47393
Olympia, WA 98504-7393